



SECTION 1 **GENERAL PROVISIONS FOR** **PUBLIC SEWER CONSTRUCTION**

Standard Specifications and Details for Construction

TABLE OF CONTENTS

<u>SECTION</u>	<u>PAGE</u>
1.1 Introduction	1-1
1.2 Definitions and Terms	1-1
1.2.1 Interpretation of Terms.....	1-6
1.2.2 Titles and Headings	1-6
1.2.3 Capitalization of Defined Terms	1-6
1.3 Revisions to the <i>Standard Specifications and Details</i>.....	1-6
1.4 General Provisions	1-7
1.4.1 Permits and Fees.....	1-7
1.4.2 License Requirements for Contractors.....	1-7
1.4.3 Pre-Construction Meeting	1-7
1.4.4 Inspection of Work	1-8
1.4.5 Field Changes.....	1-8
1.4.6 Storage of Construction Materials near a Public Sewer Manhole	1-8
1.4.7 Record Drawings	1-8
1.4.8 Construction Acceptance	1-11
1.5 Work in Public Sewer Easements.....	1-12

Section

1

General Provisions for Public Sewer Construction

1.1 Introduction

It is the policy of the Department that all Public Sewers be constructed in accordance with accepted construction standards. The purpose of the *Standard Specifications and Details* is to establish the minimum acceptable standards by which certain new Public Sewers, or modifications to existing Public Sewers, are to be constructed in Pima County. Public Sewers and related appurtenances shall be constructed in full accordance with the *Standard Specifications and Details* unless otherwise Approved in the Sewer Plans or in writing by the Sanitary Engineering Manager.

1.2 Definitions and Terms

Whenever the following terms are used in this document, the intent and meaning shall be interpreted as described in this subsection. Where there is a conflict between these definitions and those in the AAC and ARS, the AAC and ARS definitions shall apply for persons seeking a Discharge Authorization under a Type 4.01 General Permit.

100-Year Flood – A flood event that statistically has a 1 out of 100 (or one percent) chance of being equaled or exceeded on a specific watercourse in any given year.

Accept or Acceptance – The written notice from the County agreeing to the concept presented in the plans, studies, or reports required as part of a review submittal.

Affidavit of Cost – A document signed and notarized by the Applicant certifying the Cost of Work.

Agency – The jurisdictional body for whom the construction is being done, either by Permit or Contract.

Aggregate – Inert material such as sand, gravel, broken stone, crushed stone, or a combination thereof.

Applicant – A Person requesting permission to: construct a System Improvement; to connect a Property or a Unit to the Public Sewage Conveyance System (PSCS); or to conduct construction activities in the vicinity of the PSCS.

Approve or Approval – The County's written notice confirming that a submittal complies with the Department's current "Engineering Design Standards" and "Standard Specifications and Details for Construction".

As-Built Plans or As-Builts – See Record Drawings.

Augmentation –The construction of new System Improvements adjacent to or in replacement of existing Public Sewage Conveyance System (PSCS) for the purpose of increasing the capacity of the PSCS.

Backfill – The material used to fill a trench from the top of shading to subgrade or finished grade.

Bedding – The material placed at the bottom of a trench and used to support the pipe prior to the placement of Shading and Backfill.

Bill of Sale – A notarized and recordable document conveying all rights, title, and interest to the County in and to the newly constructed System Improvements, free and clear of liens, claims, charges, and encumbrances. Bill of Sale includes proof of Transfer to County of all underlying Property rights required for operation and maintenance of the System Improvements.

Building Connection Sewer (BCS) –The private sewer connecting a non-Residential building including multi-family buildings to the Public Sewage Conveyance System (PSCS). (See Service Lateral)

Calendar Day – Any day shown on the calendar, beginning at midnight, extending for a 24 hour period, and ending at midnight.

Cathodic Protection – A method for protecting metallic materials from damage caused by corrosive soils.

Code – Pima County, Arizona, Code of Ordinances; more specifically, Title 13 – Public Services, Division II – Sewers.

Collector or Collection Sewer – A sanitary sewer line with an internal diameter of less than fifteen (15) inches that receives Wastewater from two or more Service Laterals.

Construction Acceptance – The Acceptance, by the Department, for the transfer of newly constructed or modified sanitary sewer assets to the Department.

Construction Permit – An authorization for the construction of a System Improvement or a connection to the PSCS.

Contractor – A Person, acting as an Applicant's agent and who is, at all times while performing activities regulated by this Chapter, licensed by the Arizona Registrar of Contractors and bonded and insured to act in the capacity of a Contractor for the type of activity performed.

Cover – The vertical distance from the top of a buried pipe to finished grade.

Crown –The highest point of elevation on the interior pipe surface.

d/D – Ratio of flow depth (d) to pipe diameter (D).

Day – Unless otherwise designated, day shall be understood to mean a Calendar Day.

Deficiency – Departure from, or noncompliance with, specified criteria.

Department –The Pima County Regional Wastewater Reclamation Department or any successor County department.

Design Drawings – The Sewer Improvement Plans prior to their Acceptance by the Department.

Design Engineer – The Professional Engineer sealing the Design Drawings for a Project or design staff performing duties under his/her direct supervision.

Design Report – A document providing the supporting calculations, analysis, data, criteria and other material for a proposed sewer facility. Also see Sewer Design Report.

Developer – A Person contracting with the County to design and construct a Public Sewer System Improvement or connection to the PSCS.

Development – One or more Properties in common ownership and which is under consideration for service or served by the Department.

Director – The Director of the Department or: (a) any employee of the Department to whom the Director may delegate the authority to carry out the functions under this Chapter; or (b) any person who is, by operation of law, authorized to carry out such functions.

Excavation – Any man-made cut, cavity, trench, or depression in the earth's surface formed by earth removal.

Field Engineer – The Director's authorized representative to oversee inspections for the construction or modification of Public Sewer facilities.

Flow Through – Wastewater originating from Up-gradient Development that flows through a sewer located within an Area Under Development or municipality. **Force Main** – A pressurized sanitary sewer discharge line extending from a Pump Station having a horizontal length greater than 10-feet.

Full Flow – A ratio of 1.0 d/D. See d/D definition

Geotechnical Engineer – An Arizona-Registered Professional Engineer (Civil) responsible for Project soils characterization and construction backfill compaction quality control testing and certifications.

Grey Water – Residential wastewater collected separately that originates from clothes washers, bathtubs, showers and sinks. Grey water excludes wastewater from kitchen sinks, dishwashers and toilets.

Haunch – That portion of a pipe barrel extending from the bottom to the springline.

Holiday – (1) Microscopic holes in liners and coatings detected by a Holiday Test. (2) A legal holiday pursuant to A.R.S. 1-301, as amended.

Holiday Test – Electrical testing used to determine the presence and number of discontinuities in a coating film performed on a nonconductive coating applied to an electrically conductive surface in accordance with ASTM D5162 standards.

House Connection Sewer (HCS) – The private sewer connecting a Residential building and the Public Sewage Conveyance System (PSCS). The term "HCS" does not include sewers connecting Multi-family buildings to the PSCS. See Service Lateral.

Inspector – The County's representative authorized to oversee the construction of Public conveyance, treatment, and disposal facilities associated with the Public Sewage Conveyance System (PSCS).

Interceptor Sewer – A sanitary sewer line that receives Wastewater from a number of collector sewers.

Invert –The lowest point of elevation on the interior surface.

Jetting – A soil compaction technique that forces pressurized water into the bedding or backfill material in order to saturate it and force the air out. Also referred to as flooding.

Lift Station – A sanitary sewer facility that pumps Wastewater to a higher elevation without the need for a Force Main. Also see Pump Station.

Observation Permit – An authorization from PCRWRD for the purpose of witnessing construction activity in and around the PSCS.

Over-sizing – A Department-requested increase in pipe size to accommodate System Improvement capacity beyond that determined by the Department as necessary to serve the Area Under Development.

PAG Standard Specifications – The *PAG Standard Specifications for Public Improvements* latest revision.

Permit – See Construction Permit and Observation Permit.

Person – An individual, company, corporation, partnership, governmental body, or any other entity that has legal rights and is subject to obligations.

Pressure Sewer – See Force Main.

Project – The specific, coordinated design, construction or similar undertaking identified by a single Project number.

Public Sewage Conveyance System– All parts of the Public Sewerage System that convey or support the conveyance and operation of Sewage (both Residential and Commercial/Industrial).

Pump Station – A sanitary sewer facility that pumps Wastewater to a higher elevation and requires the use of a Force Main. Also see Lift Station.

Reach – A single gravity sewer line connecting into a manhole at both ends.

Record Drawings – An annotated copy of the Sewer Improvement Plan (SIP) providing the exact final location and layout of the System Improvements, the positional verification, and record clearly showing all deviations from the Approved design.

Residual Capacity –The difference between the predicted peak dry-weather flow from the Development constructing the facility and the theoretical flow in the facility at 0.75 d/D (where d is the depth of flow and D is the diameter of the pipe) based on the Manning Equation using an "n" value of 0.013.**Right-of-Way** – A general term, denoting a strip of land, property or interest therein, acquired for or dedicated to transportation and other public works purposes.

Scour – A computed value for the potential depth that material, from the bed and banks of a Wash, will be removed due to the flow of water during a 100-year flood event or long term degradation.

Service Lateral – The private sewer line between a Residential, Commercial, Industrial, or Multi-family building and its connection to the Public Sewage Conveyance System (PSCS). Also see the terms “House Connection Sewer” and “Building Connection Sewer”.

Sewage – Wastes discharged from toilets, baths, sinks, lavatories, laundries, drains, and other plumbing fixtures in residences, institutions, public and business buildings, industrial sources, mobile homes and other places of human habitation, employment, or recreation. The term Sewage does not include flows derived from stormwater or surface water sources.

Sewer Basin – All portions of the sanitary sewer collection system tributary to a common point such as an interceptor sewer or pump station. By definition, the sewers within a Sewer Basin are hydraulically linked.

Sewer Design Report – Documentation of the design flows for New Sewage Conveyance Systems and the basis for calculating the design flows. Also see Design Report.

Sewer Improvement Plan –The set of Design Drawings prepared by a qualified Arizona registered professional and intended for the construction of a System Improvement.

Shading – The material that extends from the top of the haunch to one foot (typically) above the top of pipe.

Siphon – A sanitary sewer conveyance facility used to convey Wastewater underneath an obstruction, such as a Wash or drainage culvert, without pumping.

Special Provisions – Additions and revisions to the Standard Specifications and Details, specifically Section 3, covering conditions and requirements peculiar to an individual Project.

Springline –The line of maximum horizontal dimension.

Storm Drain – A conduit or system of conduits that convey stormwater runoff, street drainage, and other wash waters or drainage but excludes Wastewater.

Stub-Out – An upstream length of pipe installed at a sanitary sewer manhole that is intended for future connection.

Trench – A narrow excavation for the installation of sanitary sewer facilities or other utilities.

Variance – A waiver, issued in writing by the Department, granting a one-time deviation from a specific design or construction standard for unique circumstances where full compliance is not realistically feasible.

Wash – A dry creek bed or gulch that temporarily fills with water after a rain event; an arroyo or an alluvial watercourse.

Wastewater –See Sewage.

Work – All labor, materials, equipment, and other incidentals necessary or convenient to the successful completion of Public Sewer construction and the carrying out of all the duties and obligations required by the Sewer Plans.

Working Day – Any Day, other than Saturday, Sunday or a Holiday, on which legal business can be conducted by Pima County.

1.2.1 Interpretation of Terms

When not inconsistent with the context, words used in the present tense include the future, words in the singular number include the plural, and words in the plural number include the singular.

1.2.2 Titles and Headings

The titles or headings of sections and subsections are intended for convenience of reference and shall not be considered as having any bearing on their interpretation.

1.2.3 Capitalization of Defined Terms

Defined terms within this document are capitalized. The Director reserves the right to interpret words or phrases listed in Subsection 1.2 - Definitions and Terms, where the context warrants.

1.3 Revisions to the *Standard Specifications and Details*

The Director will be responsible for monitoring revisions to the *Standard Specifications and Details* to ensure that the standards:

- Are consistent with current and accepted engineering practices;
- Do not impose extraordinary burdens for typical development and improvement projects; and
- Do not conflict with Code, AAC or the public's interest.

When a specific standard requires immediate attention for clarification or improvement, the Director will make a request to the Standards Committee for review. The Department will keep users of the *Standard Specifications and Details* informed of future updates through its website. Hard copy (printed) revisions will not be distributed. It is the holder's responsibility to keep the document current by periodically checking the Department's website for updates.

1.4 General Provisions

1.4.1 Permits and Fees

A Construction Permit shall be obtained from the Department at least 72 hours prior to accessing the Public Sewer or commencing work for any Project that proposes:

- New Public Sewers;
- Modifications to existing Public Sewers;
- New service connections to Public Sewers; or
- Modifications to existing maintenance access to Public Sewer manholes.

All applicable permit and Wastewater Utility fees shall be paid prior to issuance of the Construction Permit. A Construction Permit cannot be issued until:

- All applicable Department inspection fees are paid;
- The Sewer Plans, if required, are Accepted; And
- Copies of the Sewer Plans are provided to the Permitting group.

1.4.2 License Requirements for Contractors

The Contractor responsible for the construction of, modification or connection to Public Sewers, shall be an Arizona Registered Contractor with an A, A-12, AE or K-80 type license, as applicable per the Arizona Registrar of Contractors. The Contractor shall be responsible for performing all required actions that will allow completion of Public Sewer construction.

1.4.3 Pre-Construction Meeting

The Contractor shall schedule a pre-construction meeting with the Field Engineer after the Construction Permit is obtained and the FMP Approved (see Subsection 2.3). The construction of Public Sewers shall not commence until a written notice to proceed is issued by Field Engineering. Any Public Sewer construction done prior to the notice to proceed shall be removed at the sole expense of the Contractor.

The purpose of the preconstruction meeting is for the Contractor and the Field Engineer to review any special inspections requirements and items peculiar to Public Sewer construction. It is also intended to get personnel together to become familiar with the Project and each other. Prior to this meeting the Contractor, Field Engineer and all other key personnel should study the Sewer Plans and become familiar with the Project site to be well informed as to the requirements and existing conditions.

At a minimum, the Contractor shall furnish the following documentation to the Field Engineer at the pre-construction meeting:

- Survey cut sheets per Subsection 3.2.3(A)(i);

- Certification documents and batch numbers for DIP interior linings per Subsection 3.2.2(D);
- Certification documents for all materials testing (e.g. sieve analysis) per Subsection 3.1.2; and
- Shop drawings for manufactured assemblies, if applicable.

1.4.4 Inspection of Work

All Work done to or within an existing Public Sewer manhole, in order to install a new connection, shall be inspected and Approved by the Field Engineer prior to approval of private sewer construction by the Agency having jurisdiction over the building and plumbing codes.

If a new Public Sewer manhole is constructed on the existing Public Sewer line in order to install a private connection, the new manhole shall be inspected and Approved by the Field Engineer prior to approval of private sewer construction by the Agency having jurisdiction over the building and plumbing codes.

1.4.5 Field Changes

The Contractor shall notify the Field Engineer of any field change prior to proceeding with construction. The Field Engineer will determine whether the field change is de minimus or reportable. For a de minimus field change, sewer construction may continue and the field change shall be annotated on the Record Drawings per Subsection 1.4.7. For a reportable field change, construction shall not proceed on the affected areas or upstream of the affected areas until the Sewer Plans are revised and Accepted by the Department.

1.4.6 Storage of Construction Materials near a Public Sewer Manhole

Construction materials shall not be stored within 10 feet of any existing Public Sewer manhole. The contractor must contact the Department's Conveyance Division at least 48 hours in advance to request permission to temporarily block or restrict access to an existing Public Sewer manhole. The Contractor shall indicate the nature of the planned activity and length of time that access will be blocked or restricted.

1.4.7 Record Drawings

Pursuant to AAC R18-E301(E) the Record Drawings for the construction of new Public Sewers or for the repair, replacement or rehabilitation of existing Public Sewers, shall be submitted to PCDEQ and the Department for review and Approval, prior to Construction Acceptance (see Subsection 1.4.8). Emergency repairs are exempt from the prior Approval requirement but not from the requirement to submit Record Drawings.

The Contractor shall be responsible for retaining an Arizona Registered Land Surveyor to provide the exact final location and layout of Public Sewers, and

preparing the sewer Record Drawings in accordance with the following requirements:

- A. Record Drawings shall be certified by an Arizona Registered Land Surveyor or an Arizona Registered P.E. (Civil). The following certification shall appear on each sheet of the Record Drawings: a seal per AAC R4-30-304, the label "AS-BUILT" and the contact information of the certifier's employer. The cover sheet shall also include the following certification statement: "I HEREBY CERTIFY THE ANNOTATIONS (STRIKETHROUGH AND AB) PROVIDED ON THESE DRAWINGS WERE BASED ON AN FIELD SURVEY CONDUCTED UNDER MY SUPERVISION AND ACCURATELY DEPICTS EXISTING FIELD CONDITIONS TO THE BEST OF MY KNOWLEDGE AND BELIEF".
- B. The party responsible for annotating the Record Drawings shall obtain either a full-size copy or an electronic copy of the original and complete Sewer Plans, with all seals, acceptance signatures and design revisions. The quality of the hard copy shall be equivalent to the original Sewer Plans. The quality of the electronic copy shall have a minimum resolution of 200 x 200 dpi.
- C. The Record Drawings submittal shall include a complete and full-size set of the Sewer Plans. If a complete set of plans includes sheets that are not related to Public Sewer construction, the Field Engineer may allow these sheets to be excluded from the Record Drawings.
- D. The Record Drawings submittal shall be of a quality that ensures clear reproduction through electronic scanning and microfilming. The quality of these copies shall conform in appearance, scale, resolution and accuracy to the original Sewer Plans. All design information and annotations shown on the Record Drawings shall be in black ink with a pen thickness sufficient to show the As-Built information in a clear and legible manner.
- E. For deviated design values, including water/sewer separation, add a strikethrough of the design value with the as-built value shown next to it. For non-deviated design values, add the letters "AB" next to the design value to indicate it was verified with the field survey and is accurate. The use of clouding, *except for design revisions*, is not acceptable for as-built annotation.
- F. As-Built annotations shall verify or update the layout and horizontal control data for each new manhole, at the center of its base (e.g. station and offset). This shall also be accomplished by providing a separate tabular report with the manhole number, and the Northing and Easting coordinates based on SPCS (NAD83) for all new manholes and Point of Connection manholes.
- G. As-Built annotations shall verify or update all pipe invert elevations and if required by Field Engineering the rim elevations for new or modified

- manholes. Elevation data shall be consistent with the vertical datum used in the Sewer Plans.
- H. As-Built annotations shall verify the location, nominal diameter, slope, length and pipe material for each reach of new sewer line. The As-Built slopes for each reach shall be calculated based on the horizontal reach length between the interior walls of each manhole and the invert of the sewer line at these locations.
 - I. As-Built annotations shall verify or update the layout of new service laterals (HCS/BCS) in plan view. In addition, the Record Drawings shall provide a separate tabular report with the lot number, Northing and Easting coordinates of the private cleanout riser based on SPCS (NAD83), the distance from the HCS/BCS at the sewer line connection to the nearest downstream manhole.
 - J. Pursuant to Arizona Blue Stake law (ARS 40-360.21 to 40-360.32) the Department is responsible for locating service laterals (HCS/BCS) installed after December 31, 2005. Where service laterals are damaged due to inaccurate annotations, the registrant and the firm certifying the Record Drawings may be held accountable for the cost of repair.
 - K. The use of non-transparent blocks, masking, or the pasting of information onto the Sewer Plans that would cover any language, design data or line work shown on the original Sewer Plans is not allowed. If additional room is required for annotations, an additional sheet shall be added to the Record Drawings.
 - L. The Record Drawings shall include any construction variances or design revisions that occurred during the progress of construction.
 - M. Copies of Record Drawings for New Force Mains shall be submitted to Field Engineering within thirty (30) days of completion of the project. As-built annotations shall verify or update the horizontal alignment of the Force Main, the location of any bends, beginning and ending of curves, location of Test Stations, and the location of air-release valves. In addition, top of pipe elevations and/or grade breaks, if shown, shall be verified or updated. Coordinates of the Force Main shall be provided at 200 foot intervals and at all bends or changes in direction in tabular format. Coordinates of all air-release valves and test stations shall also be provided. Provide in tabular format the "Northing" and "Easting" coordinates of the Force Main based on SPCS (NAD83). At a minimum, provide one (1) horizontal tie from a survey monument. Add reference ties along the Force Main alignment from two permanent features (fire hydrants, power poles, fence corners, etc.) to horizontal angles, air-release valves, and Test Stations.
 - N. Abandoned manholes shall be noted as either completely or partially removed. Abandoned sewer pipe shall be noted as completely removed, abandoned in-place, grouted, or burst.

- O. The beginning and end stations of ductile iron pipe (DIP) segments shall be included.
- P. Subdivision plat and easement recording data, i.e. Sequence Number(s), shall be properly documented on the Record Drawings.

Copies of the Record Drawings shall be submitted to the Field Engineer within 30-days of the completion of all sewer construction. A digital file shall be provided depicting property lines, monumentation ties, sewer manholes and cleanouts, sewer pipes, and HCS's. In addition, electronic text files shall be provided for sewer manholes with manhole numbers, sewer depth, and northing and easting coordinates. A text file of HCS northing and easting coordinates shall also be provided. Contact the Department's Field Engineering Section for additional specific submittal requirements. The submittal will be reviewed for conformance to the above requirements. Incomplete or non-conforming submittals will be returned for revisions. The Record Drawings must be Approved by the Department prior to completion and processing of the ECC.

1.4.8 Construction Acceptance

Upon written notice from the Contractor of completion of the Work, the Field Engineer will conduct a final inspection. If all construction is complete and in accordance with the Sewer Plans and the *Standard Specifications and Details*, the Field Engineer will process the Engineer's Certificate of Completion (ECC) per AAC R18-9-E301(E).

If, however, the final inspection discloses any Work, in whole or in part, as being unsatisfactory or not complete, the Field Engineer will notify the Contractor and he shall immediately correct such deficiencies. Upon completion and correction of the Work, another final inspection will be required to verify the Work has been satisfactorily completed.

The Contractor shall provide the following documentation to the Field Engineer before the ECC is processed by the Department:

- Record Drawings conforming to the requirements of Subsection 1.4.7;
- Materials testing documentation per Subsection 3.1.2 and 3.3.2;
- Pipe installation testing documentation per Subsection 3.2.3(D);
- Manhole installation testing documentation per 3.3.3(C);
- Backfill density testing documentation per Subsection 3.1.3(F); and
- If applicable, a Memorandum of Understanding per for Type III buried cleanouts per 3.2.3(C).

The Applicant shall provide the following documentation to the Permitting group of the Department before the Discharge Authorization (DA) request is processed:

- A Notarized Bill of Sale;
- An Affidavit of Cost for Public Sewers; and
- A check for review fees.

The Department will issue a letter of acceptance and release of assurances to the Applicant upon receipt of the DA from ADEQ, as required to obtain a certificate of occupancy.

1.5 Work in Public Sewer Easements

The Department has the right to install anywhere within a Public Sewer easement temporary or permanent underground or above ground facilities that may be required to monitor, operate, maintain, repair or replace Public Sewers, or under emergency conditions, pump or otherwise convey wastewater.

The Department assumes no liability for damage to or removal of any vegetation, above ground or below ground facilities, surface treatments, materials, equipment or structures placed within a Public Sewer easement or within 20 feet above its surface by anyone other than the Department.

The property owner shall be liable for injury to personnel and/or damage to maintenance vehicles or construction equipment that result from contact with any prohibited encroachments anywhere within the full width of the Public Sewer easement or within 20 feet above its surface, or from any actions necessary to remove such encroachments from the easement. Liability for injury or damage includes personnel and equipment of the Department.

The Department will endeavor to provide advance notice to the property owner of the need to utilize/access Public Sewer easements and/or Public Sewers. However, the Department has no obligation to provide such advance notice and shall not provide notice under emergency conditions.

Temporary storage of vehicles, equipment, or materials by the property owner is not allowed within the Public Sewer easement without the prior written permission of the Department.



SECTION 2 **WASTEWATER FLOW** **MANAGEMENT**

Standard Specifications and Details for Construction

TABLE OF CONTENTS

<u>SECTION</u>	<u>PAGE</u>
2.1 Introduction	2-1
2.2 Planning for Wastewater Flow Management	2-1
2.2.1 Conditions that Require an FMP	2-1
2.2.2 Preparing the Flow Management Plan	2-2
2.2.3 Flow Management Data	2-2
2.2.4 Formats of the Flow Management Plan.....	2-2
2.3 FMP Approval Process for Construction	2-3
2.4 Determining Wastewater Flow Rates for Existing Sewers	2-4
2.4.1 Flow Metering Method	2-4
2.4.2 Assumed Depth Method.....	2-5
2.4.3 ADEQ Design Method.....	2-6
2.5 Design Flows for Flow Management Measures	2-6
2.6 Standard Measures for Wastewater Flow Management.....	2-7
2.6.1 Phasing.....	2-7
2.6.2 Pumping Systems.....	2-7
2.6.3 Manholes for Pumping or Gravity Bypass	2-9
2.6.4 Plugs.....	2-10
2.6.5 Gravity Bypass Measures	2-11
2.6.6 Odor Control	2-11
2.6.7 Daily Inspection Logs.....	2-11
2.6.8 Direct Connections to Existing Sewer Lines	2-11
2.6.9 New Manholes on Existing Sewer Lines	2-12
2.6.10 New Sewer Line Connections to Existing Terminal Manholes	2-13
2.6.11 New Lateral Sewer Line Connections to Existing Manholes	2-14
2.6.12 Sewer Line Repairs and Pipe Section Replacements	2-15
2.7 Formatting Requirements for Flow Management Plans	2-15
2.7.1 Simple Format FMP	2-15
2.7.2 Detailed Format FMP	2-16
2.7.3 Wastewater Flow Data.....	2-18
2.7.4 Map of Flow Management Measures	2-18

2.7.5	Sanitary Sewer Overflow Spill Prevention Plan	2-18
2.8	Customer Notifications for Service Interruptions	2-19

DRAFT

Section
2

Wastewater Flow Management

2.1 Introduction

When a modification or connection is proposed to a live Public Sewer line, the Contractor or Design Engineer herein known as the Preparer shall prepare a written Flow Management Plan (FMP). The FMP shall be submitted to and approved by RWRD Field Engineering prior to the start of construction. Details of the FMP shall include:

Management of the wastewater flows in a planned and proactive manner to prevent any sanitary sewer overflow (SSO).

Conformance to all applicable environmental and regulatory requirements.

During construction the Contractor shall furnish, operate and maintain all equipment necessary to provide continuous service to all tributary customers of any affected sewer line.

2.2 Planning for Wastewater Flow Management

2.2.1 Conditions that Require an FMP

An FMP shall be required for any proposed construction that encroaches into the impact zone of existing Public Sewers (see Figure 2-1). Proposed construction includes, but is not limited to, any type of connection to or any modification of a Public Sewer line or manhole. Proposed construction within the impact zone that has the potential to undermine or cause displacement of any asset shall also require an FMP.

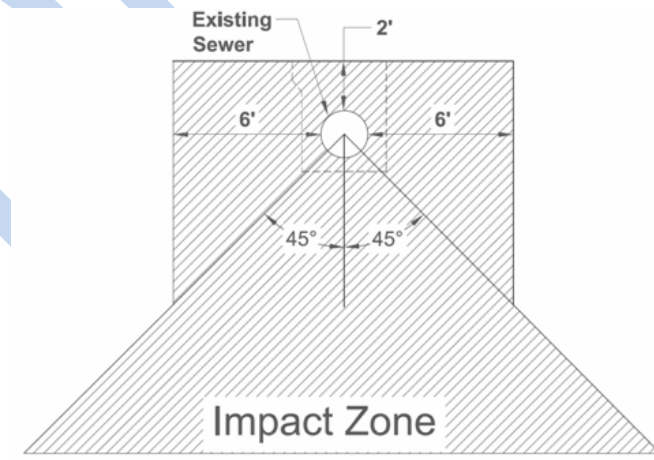

Figure 2-1: Impact Zone for Existing Sewer Lines

Depending on the sewer type, size, condition, and flow volume, RWRD Field Engineering may increase the Impact Zone. Field Engineering will make the determination at the time of plan submittal.

RWRD may require a new FMP or modification of an existing FMP if construction is anticipated to encroach into the Impact Zone of the existing system.

A FMP may include the option at RWRD's discretion for hand excavation within the Impact Zone above the sewer pipe in lieu of a pump bypass.

Projects that require wastewater flow management measures will require an FMP completed by the Preparer as part of the documents for the work. The FMP may be shown either as part of the Sewer Plans or as a separate stand-alone document. The FMP must show a complete and practical method for handling the sewage flows while the designed work is completed. The Contractor may request modifications to the FMP.

2.2.3 Flow Management Data

At a minimum, the FMP shall include the following data:

- A. Wastewater flow rates, either:
 - i. Metered with the time and date at each existing manhole; or
 - ii. Estimated, showing the method of calculation (e.g. $\frac{1}{2}$ flow, full flow, etc.) and the results;
- B. The nearest upstream and downstream manholes including the following information:
 - i. Manhole diameters and materials;
 - ii. Pipe diameters and materials
 - iii. IMS Manhole Numbers
- C. A description of the available flow management options and constraints.
- D. A note that the Contractor is required to adhere to the Departments flow management standards, specifically Section 2 of the RWRD Standard Specifications and Details.

2.2.4 Formats of the Flow Management Plan

Criteria for determining the format of the FMP as well as the content shall depend on the diameter of the existing Public Sewers to be impacted.

A. Small Lines

When proposed construction impacts Public Sewers having pipe sizes of 12-inches in diameter or less (i.e. small lines), the Sewer Plans may serve as the FMP if flow data per Subsection 2.2.3 is incorporated into the plan set. A separate and stand-alone FMP may be provided but will not be required. Projects that include manhole connections, new manholes over existing lines

or other small modifications may utilize the letter format presented at the end of Section 2.

B. Large Lines

When construction impacts Public Sewers having pipe sizes greater than 12 inches in diameter (i.e. large lines), a separate and stand-alone FMP shall be prepared. In general these FMP's shall be sealed by an Arizona Registered Engineer. This requirement may be waived for manholes that will receive pipe connections or invert modifications. Waivers will be provided at the discretion of the Field Engineering Manager. Any large line that requires the removal of a section of pipeline for replacement or other modification will require review by an Arizona Registered Engineer. Large line FMP's shall include:

- A. Flow management data, per Subsection 2.2.3;
- B. A plan view of the proposed flow management bypass layout;
- C. Pump calculations for Total Dynamic Head, flow rates and head losses;
- D. Sizing of bypass pumping units and setup;
- E. Temporary wet wells if necessary;
- F. Discharge piping materials, lengths and diameters;
- G. A list of necessary standby equipment and any equipment checks required before bypass is placed into service;
- H. A list of required equipment submittals if a gravity bypass system is proposed. Sheets showing a plan and profile of the system along with supporting hydraulic calculations;
- I. Any additional information necessary for the Contractor to quickly implement the bypass activities. The design engineer may present any unusual site specific conditions for review by the Field Engineer in consideration of an alternative flow management proposal.

2.3 FMP Approval Process for Construction

The Contractor shall ultimately be responsible for implementing an Approved FMP that is appropriate to Project-specific conditions. The Contractor has the option to either resubmit the FMP originally developed by the Preparer or develop a new FMP. If the Contractor elects to use the original FMP, the Contractor shall field-verify all existing conditions and flow rates before it is submitted for Approval by the Field Engineering section.

The pre-construction meeting shall not be scheduled until the FMP is approved by the Field Engineering section. It is recommended that the Contractor submit the FMP at least 5 days prior to the anticipated pre-construction meeting date.

The Contractor shall submit the FMP electronically as a portable document format (PDF) to:

PCRWRD Field Engineering
1313 S. Mission Rd., Bldg. 9
Tucson, AZ 85713-1398
Email to: FE_RWRD_Reviewers@pima.gov

The Contractor shall, at his expense, obtain all permits necessary for the installation and operation of flow management measures. The Contractor shall notify the assigned Field Engineering Inspector at least 72 hours in advance of commencing either Public Sewer construction or flow management measures. Where indicated in the Plans, the Contractor may also be required to provide at least 72 hours advance notice to the designated community relations representative of the Department.

Any questions or concerns regarding the development of the FMP should be directed to the Field Engineering Manager. The Field Engineering Manager reserves the right to allow or modify specified requirements on a case-by-case basis.

In cases where there are no wastewater flows in an existing sewer, the Contractor may request a waiver of the FMP requirements. In most cases where there are no flows the minimum requirement will be the placement of a plug in the outlet side of a manhole adjacent to the work area.

2.4 Determining Wastewater Flow Rates for Existing Sewers

The Department recognizes specific methods for determining the actual wastewater flow rates in existing sewers for flow management. The Field Engineering Manager may allow the modification of a selected method for determining the actual wastewater flow rates or may consider alternatives for unique field conditions. Such conditions may include existing sewer lines with reaches having significant slope variations or unique channel configurations within existing manholes.

2.4.1 Flow Metering Method

The most accurate method for determining wastewater flow rates is flow metering. This method may require the cleaning and flushing of existing sewers prior to the installation of metering equipment. Metering equipment will typically remain installed in the existing sewer for a period of 1 to 2 weeks. Flow metering data will expire 18 months from the date it was obtained. After 18 months, the data must be recertified prior to commencing flow management measures. The flow results obtained by the flow metering method shall be represented as peak dry weather flow and used as the basis for the flow management planning.

The effectiveness of this method is limited to ideal field conditions described as follows:

- A. Flow depths should range between 2.5 inches and $0.60 [d/D]$, at all times;
- B. Flow velocities should range between 2 fps and 6 fps, at all times;
- C. Force main discharge should not be immediately upstream;
- D. Nearest adjacent manhole should be at least 60 pipe diameters away;
- E. Flow channel should be straight and without lateral connections;
- F. Flow channel should conform in shape to the bottom half of the pipe.

If a recorded precipitation event occurs during the metering period, which results in increased flows from inflow and infiltration (I/I), the Field Engineering Manager may allow the increase in flow rates to be ignored. This decision shall only be made after consultation with the Flow Monitoring group.

The Flow Monitoring group of the Department may provide flow metering services after a *Temporary Flow Metering Request* form is submitted. Current forms should be requested from the RWRD Flow Monitoring Group or downloaded from the Departments website. Submittal of the flow metering request should be completed at least 9 weeks prior to the date that the flow data is needed (4 weeks for scheduling, 3 weeks for data collection and 2 weeks for data analysis). Flow metering requests will be reviewed and scheduled on a first-come, first-served basis.

When the proposed sewer construction involves an existing small Public Sewer (pipe sizes of 12 inches in diameter or less), the flow metering request shall include:

- Temporary Flow Metering Request Form (for a blank copy of this form check the engineering forms page on the RWRD website);
- A plan depicting the current sewer basin area and all contributing sewer lines to the point of the proposed bypass (PimaMaps will be acceptable);
- Construction schedule.

When proposed sewer construction involves an existing large Public Sewer (pipe sizes greater than 12 inches in diameter), the flow metering request shall include:

- Review and condition assessment of the impacted manholes;
- A list of all seasonal flow contributors identified within the sewer basin (i.e. schools, RV parks, etc.); and
- A preliminary version of the flow management design being developed.

The Flow Monitoring group will review these requests and notify the applicant, if the flow metering request can be accommodated. When existing field conditions are not ideal for reasonable flow metering or the task cannot be performed by the Department for other reasons, the Flow Monitoring group will recommend other methods for estimating current wastewater flow rates.

If the Flow Monitoring group cannot provide services within a reasonable amount of time or within the frame that was requested, the following methods may be used for flow management planning, when authorized by the Field Engineering Manager:

- At their own expense, the property owner or the Developer may hire an Approved third-party flow metering service; or
- Utilize the Assumed Depth Method-per Subsection 2.4.2.

2.4.2 Assumed Depth Method

Where metering does not yield reliable results or cannot be completed, flows may be estimated based on an assumed depth calculation. This method is subject to approval after the Field Engineering section has verified such depth conditions

during the flow management review process. With low depths of flow (less than 2.5 inches), the existing pipe shall be assumed to be flowing half-full. With high depths of flow ($0.60D < d < 1.0D$), the existing pipe shall be assumed to be flowing full. The Manning's formula shall be used to estimate wastewater flows. The flow results obtained by the Assumed Depth Method shall be represented as peak dry weather flow and used as the basis for flow management planning.

2.4.3 ADEQ Design Method

Where accurate flow data is not needed, existing wastewater flow rates may be estimated in accordance with the method required for sewer design by ADEQ for calculating peak dry weather flows. This method is more specifically described in AAC R18-9-E301(D) – Type 4 General Permits and R18-9-Table 1 - Unit Design Flows. This method may be more practical for flow management planning purposes in the early stages of a project and may be superseded by a more precise method, such as flow metering, if elected by the Contractor.

2.5 Design Flows for Flow Management Measures

The Contractor will be responsible for providing wastewater flow management measures that are capable of conveying the existing wastewater flows under all conditions, including wet weather. All peak dry weather flows (PDWF) shall be multiplied by a factor of 1.5 to obtain the design flow for wastewater management measures, such as pumping or gravity bypass systems. A factor of 1.5 shall be used to accommodate most variations in flow and wet weather conditions, unless otherwise specified by the Field Engineering. All design flows will be reported in gallons per minute (gpm).

Example 2.1 – Calculate Bypass Pumping Flow Rate:

The Flow Monitoring group provides the PDWF for an incoming sewer line at manhole number MH-5462 as 1.17 mgd. Determine the required design flow to properly specify the pumps to be used for the bypass pumping measures.

Solution:

$$Q_{FM\ Design} = PDWF \times 1.5$$

$$\text{Where: } Q_{FM\ Design} = \text{Pumping Design Flow}$$

$$Q_{FM\ Design} = 1.17\ mgd \times 1.5 = 1.755\ mgd$$

$$Q_{FM\ Design} = \frac{1.755\ mgd}{1,440\ min/day} = \frac{1.755 \times 10^6\ gal/day}{1,440\ min/day} = 1,218.75\ gpm$$

Round up to the nearest 5 gpm; therefore: $Q_{FM\ Design} = 1,220\ gpm$

2.6 Standard Measures for Wastewater Flow Management

The following are standard measures intended for typical small Public Sewer line construction and may not be applicable in all cases, as actual site conditions may vary. Large Public Sewer Line construction will require early contact with the Field Engineering Manager to identify project-specific requirements.

Sewer bypassing, either pumping or gravity, will consider project-specific conditions and the Contractor's level of expertise. Bypass pumping is more appropriate for short durations of construction or restricted areas. Gravity bypass measures are more appropriate for long durations of construction, for large sewer lines, or for open undeveloped areas. The Preparer shall be responsible for determining the most appropriate method for Approval by the Field Engineering section.

2.6.1 Phasing

On some projects, it may be necessary or more cost-effective to phase flow management measures simultaneously with regulatory approvals. Such a case might involve getting a discharge authorization for an initial phase of work so a new pipe could be in service for a subsequent phase of work. The Contractor will be responsible for any such phasing of flow management measures. The FMP shall clearly identify the phasing of the flow management measures, the wastewater flows associated with each phase, the details for flow management measures, and any special construction.

2.6.2 Pumping Systems

Flow management pumping measures may require a pump truck or a stationary bypass pumping system. The type of pumping measure will depend on the flow in the existing sewer line, the duration of the new construction, and site specific conditions. With Approval of the Field Engineering section, the Contractor may determine the type of pumping measure to be used on a project-specific basis.

A. Pump Trucks

The use of a pump truck (Vactor) for flow management measures is most suitable for low flow rates and short durations of construction. The use of pump trucks will be limited to flows of 90 gallons per minute or less.

B. Stationary Bypass Pumping Systems

The use of stationary bypass pumping systems for flow management measures are more suitable for high flow rates, long durations of construction, and inaccessible site conditions.

- i. Fuel storage shall be provided for stationary pumping measures sufficient for 24 hours of operation. Stationary pumping units shall be quiet during operation. If necessary, the Contractor shall provide noise suppressing systems, such as

enclosures, barriers or mufflers. Pumping units shall also adhere to any noise abatement requirements of the local jurisdictional agency.

- ii. Stationary bypass pumping systems shall be tested with clean water and shall be located within a leak containment berm. The containment berm shall be fabricated of flexible impervious material and will be placed to collect all leakage from the pump operation. Containment berms shall specifically be manufactured for the containment of hazardous liquids and will be supported with factory brackets. Pumps will be tested at anticipated operating pressures and all connections will be tightened to minimize any leakage-

Example 2.2 – Calculate the Required Number of Spare Pumps:

The Contractor specifies 3 pumps, each at 410 gpm, for a pumping flow rate of 1,220 gpm (see Subsection 2.5). Determine total number of pumps required for stationary bypass pumping measures.

Solution:

$$\text{Spare Pumps} = \# \text{ Design Pumps} \times 0.5$$

$$\text{Spare Pumps} = 3 \text{ Design Pumps} \times 0.5 = 1.5$$

$$\text{Round 1.5 up to the nearest integer} = 2 \text{ Spare Pumps}$$

$$\text{Total Required \# Pumps} = 3 \text{ Design Pumps} + 2 \text{ Spare Pumps} = \mathbf{5 \text{ pumps}}$$

- iii. Suction piping shall be rigid material, steel-reinforced pipe, butt-fused HDPE or other material as Approved by the Field Engineering Manager. Separate suction lines shall be used for each pump. Suction manifolds will not be permitted. Spacing between suction lines shall be sufficient to prevent interference and vortexing. Each suction line shall be installed without provisions for debris control (e.g. screens). If debris is a problem, the Contractor shall consult with the Field Engineering Manager for appropriate counter measures.
- iv. Two pumping discharge lines may be required for redundancy. Excess capacity in a single discharge line will not be accepted in lieu of a redundant pipeline. Discharge lines shall be butt-fused HDPE of a pressure class adequate for the design pressure, with a minimum nominal outside diameter of 3 inches. Victaulic joint connections may be used with the Approval of the Field Engineering Manager. Structural calculations may be required for some installations as determined by the Field Engineering Manager. -Where air relief valves are required, a redundant valve shall be installed. All discharge from air relief valves will be contained and not allowed to leak onto the ground surface.

Vertical bends shall be installed at the discharge manhole as needed to direct flows into the outgoing sewer line to prevent splashing and excess scour affects. Where applicable the Contractor shall install measures for protecting discharge lines from vandalism.

Sections of HDPE lines with gouges or scrapes that are 6 inches in length and 50% of the wall thickness shall be removed from the system and replaced with acceptable material.

Where discharge lines will cross paved roads, the Contractor shall provide measures as needed for protecting the lines from vehicular damage and for the safe and efficient flow of traffic. Approved measures for road crossings include the use of prefabricated pipe ramps or cutting pavement and burying the line with an approved minimum cover. Such crossings shall be capable of handling H-20 highway loadings and shall not be susceptible to damage by vehicles with low height clearances.

v. Testing

- a. Pumping equipment shall be tested with clean water and located in a nearby staging area.
- b. The discharge system manifold and piping shall be required to hold a minimum test pressure of 45 psi at the lowest point in the system unless a higher pressure is warranted. This test shall be conducted in the presence of the PCRWRD Inspector. The duration of the 45 psi pressure test will be determined by the PCRWRD Inspector.
- c. The pump bypass system shall be required to produce a minimum sustained vacuum of 15 inches mercury on the pump intake side. The vacuum shall be measured using a vacuum plate, pump mounted gage, or other means approved by the PCRWRD Inspector. This test shall be conducted in the presence of the PCRWRD Inspector. The PCRWRD Inspector may require more than 15 inches of sustained vacuum for manholes generally deeper than 15 feet.
- d. Pump bypass operations shall not commence until authorized by the PCRWRD Inspector.
- e. The Contractor shall maintain daily inspection logs per Subsection 2.6.7 for recording pump/motor operational data and the condition of discharge lines at maximum time intervals of one-half (1/2) hour throughout the duration of pumping.

2.6.3 Manholes for Pumping or Gravity Bypass

- A. The use of temporary manholes for pumping or gravity bypass measures shall be Approved by the Field Engineering Manager-

Once field conditions have been verified, the Contractor shall submit a written procedure for any planned cuts into the tops of pipes and for the safe removal and preservation of coupons. Pipe coupons shall be cut at an angle to prevent it from falling into the existing pipe. In the case that a coupon is damaged, is destroyed or is otherwise unable to be replaced intact into the cut pipe, the Contractor shall have a plan in place to fabricate a coupon of similar material, or

material approved by the Department that can be attached to the cut pipe in a manner acceptable to the Department.

At the conclusion of pumping or gravity bypass measures, pipe coupons shall be reinstalled using a high-strength, moisture-insensitive, structural epoxy paste adhesive. All temporary piping shall be removed and flow channels filled with concrete to form a smooth surface. For temporary manholes, the coupon area of the pipe and bench shall be capped with a flat top section coated with an approved material. Temporary manholes shall be abandoned per Subsection 3.3.3(E). The precise location of abandoned temporary manholes shall be annotated on the As-Built Plans and abandonment monuments installed per S.D. RWRD-503.

Where the surcharging above the bench of a manhole is proposed to allow for pumping, the depth of surcharge shall be limited to 2 feet or sufficient depth to allow for pump operation. If the manhole sections are severely deteriorated or cracked, the manhole shall be repaired with an approved material to an elevation at least 2 feet above the proposed surcharge level.

- B. The Contractor shall maintain daily inspection logs for recording depth of water in pumping manholes at a maximum time interval of one-half (1/2) hour per Subsection 2.6.7.

2.6.4 Plugs

The installation of plugs shall only occur during low-flow conditions. Sewer plugs for flow management measures shall be approved pneumatic pipe plugs with permanent indelible tags to identify the Contractor. Solid plugs shall be installed in the sewer line and secured to an affixed object with a chain or cable. As a secondary safety measure for sewer lines that extend to daylight, a second plug shall also be installed at the opposite end of the same sewer line. The installation of solid plugs shall conform to the requirements of the manufacturer and OSHA.

Prior to installation of a pneumatic plug, the Contractor shall inspect the host pipe for imperfections that could cause damage to the plug or the pipe during inflation. The results of this inspection may require an alternate installation location for the plug installation. The Contractor shall ensure that the pneumatic plug is properly positioned in the pipe and closely monitor the air pressure gage during inflation. The Contractor shall also verify that the air lines are not compromised by tension, friction or other conditions that could cause damage or failure. The Contractor shall install plugs and isolation gates only during low-flow conditions. The Contractor shall maintain daily inspection logs per Subsection 2.6.7 for recording the air pressure of pneumatic plugs at a maximum time interval of one-half (1/2) hour.

Flow through plugs may be utilized for work involving manhole connections, rehabilitation of manhole interiors, or controlling flows in manholes with two outlets. Flow through plugs shall have flexible steel reinforced or rigid connection piping to direct the flow through the manhole invert. Any type of lay flat hose or plain tubing will not be allowed. Plugs will be sized to allow a minimum reduction of pipe size. In general, plugs may reduce the flow diameter by one pipe size. Multiple size

plugs may be considered depending on site specific flow conditions. The size of the plug and flow through diameter shall be identified in the FMP.

Prior to the removal of any line plug the Contractor shall remove all debris from flow channels and manhole benches.

2.6.5 Gravity Bypass Measures

Temporary gravity bypass measures shall be designed for flows per Subsection 2.5. Gravity flow measures shall use pipes that are equivalent in size and slope to the existing system, unless otherwise approved by the Field Engineering Manager. The FMP submittal (see Subsection 2.2.4(B)) for gravity bypass measures shall also include a hydraulic analysis proving that the proposed gravity bypass system will be adequate to control the design flows. Materials for gravity bypass pipes shall be adequate for Public Sewer applications and Approved by the Field Engineering Manager. The use of corrugated metal pipe or other storm drain piping materials for flow conveyance is not permitted.

Prior to excavation, the Contractor shall be responsible for accurately locating all existing utilities.

2.6.6 Odor Control

The Contractor shall provide measures for minimizing odors and preventing their migration to populated areas. Approved odor control measures may include lids, shroud covers or chemical agents. In cases where odors are excessive, the Department may require that an Approved odor control unit be installed on site.

2.6.7 Daily Inspection Logs

The Contractor shall ensure that all bypass measures are working correctly and not leaking with regular, frequent inspections. The Contractor shall have on-site, qualified personnel monitoring flow management measures at all times during bypass operations (24 hours per day, 7 days per week).

The Contractor shall also maintain daily inspection logs, for specific flow management measures. Typical inspection log forms are available from the Field Engineering section. The Contractor shall keep all flow management inspection logs at the site and shall have them available for review by the Department at all times. At the conclusion of the project, a copy of all inspection logs shall be provided to the Field Engineering section in PDF format prior to Construction Acceptance.

2.6.8 Direct Connections to Existing Sewer Lines

When a new service lateral (HCS/ BCS) will be connected directly to an existing Public Sewer line, the best management practice will depend on the depth of flow in the pipe at the time of connection. The connection should be completed during low flow periods or when the flow is less than one-half of the pipe diameter. If there

are no times when the flow is below one-half of the pipe diameter, bypass pumping or other measures will be required.

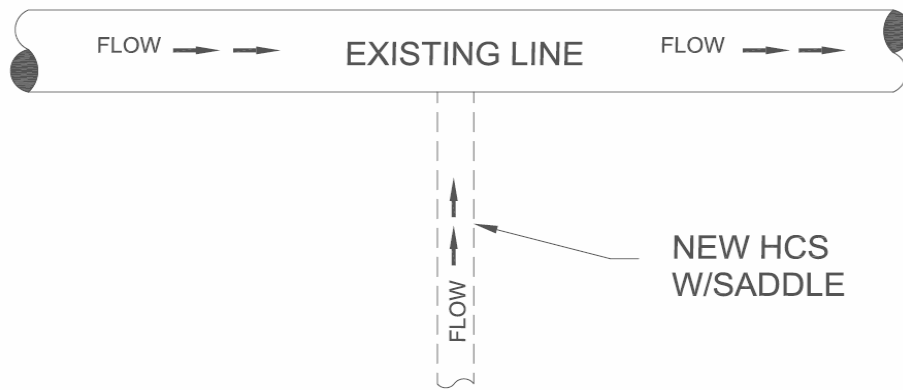

Figure 2-2: Direct Connection to Existing Sewer Lines

2.6.9 New Manholes on Existing Sewer Lines

When a new manhole will be constructed on an existing Public Sewer line, the best management practice for flow management will depend on the depth of flow in the pipe during the time of the construction connection.

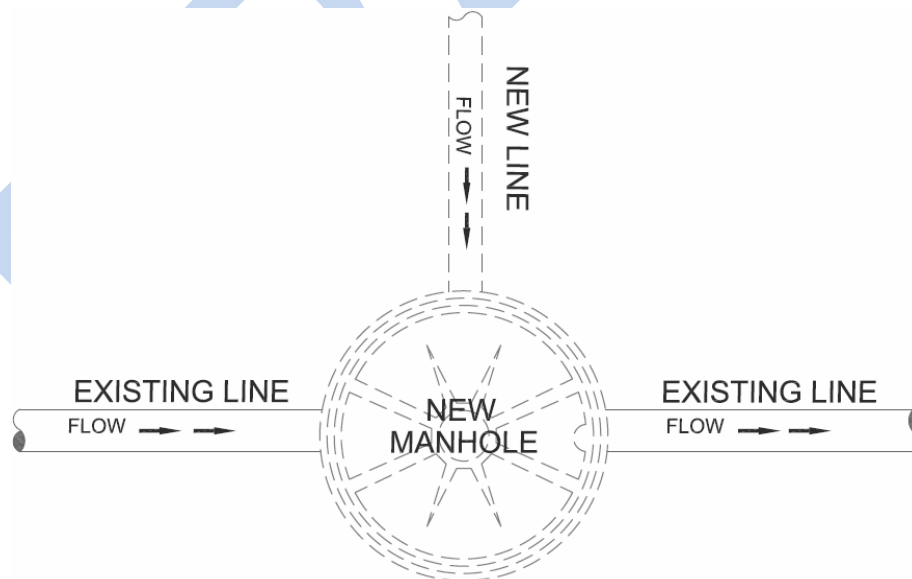

Figure 2-3: New Manhole on an Existing Sewer Line

A. Low and Moderate Depths of Flow

When the depth of flow in an existing pipe is moderate (2.5 inches to 0.60 [d/D]), two best management practices will be available, depending on the material of the existing pipe. When the existing pipe is a flexible material, such as PVC or DIP, the construction of a poured concrete base per S.D. RWRD 303 may be permitted without standby pumping measures and with the existing pipe fully intact. However, when the existing pipe is a rigid material, such as VCP or ACP, the upstream pipe(s) shall be plugged at the nearest upstream manhole(s) and monitored with standby pumping measures. This requirement may be waived for rigid pipes that have been lined with a Cured in Place Pipe (CIPP).

The Field Engineering Manager may also waive the need for standby pumping measures if the depth of flow is low (less than 2.5 inches) and the Contractor has demonstrated substantial experience with the construction of manholes in accordance with S.D. RWRD-303.

B. High Depths of Flow

When the depth of flow in an existing pipe is high (greater than 0.60 [d/D]), the best management practices will be limited to standby pumping at the nearest upstream manhole(s). This requirement may be waived at the discretion of the Field Engineering Manager.

2.6.10 **New Sewer Line Connections to Existing Terminal Manholes**

When a new sewer line will be connected to an existing terminal manhole, the downstream sewer line shall be plugged to prevent construction debris from being flushed into the existing sewer and also to protect the work area from an unanticipated backwater surcharge. After all work is completed within the manhole and all debris removed, the plug shall be relocated to the new pipe.

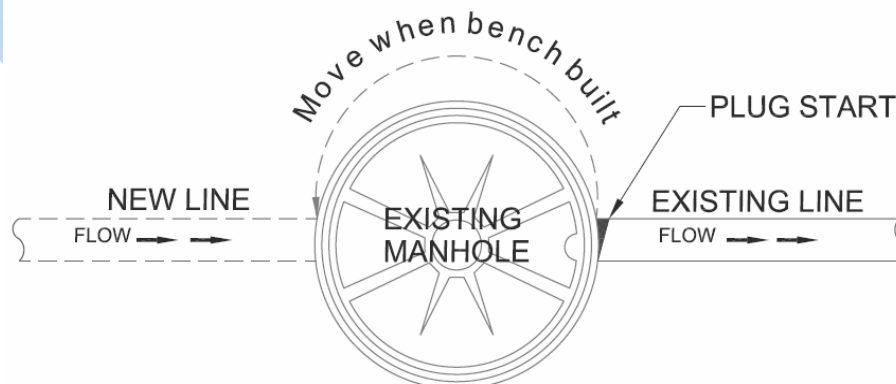

Figure 2-4: New Sewer Line Connection to Existing Manhole

2.6.11 New Lateral Sewer Line Connections to Existing Manholes

When a new lateral sewer line will be connected to an existing manhole, as shown in Figure 2-5, the flow in the existing manhole governs the flow management options. Connections to an existing manhole are made either by using an existing block-out or by coring the manhole above the base. Flow management will be necessary to prevent any debris from entering the existing flow channel. Options for flow management are providing an invert cover in accordance with S.D. RWRD 306 or utilizing a flow through plug within the invert channel.

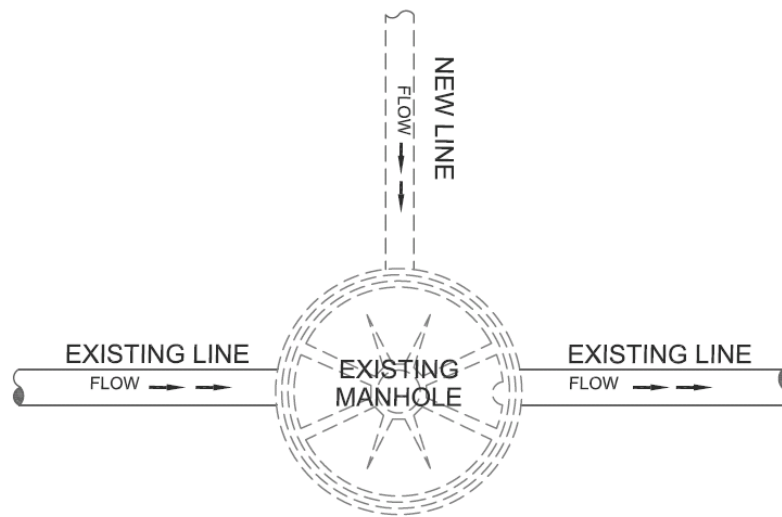

Figure 2-5: New Lateral Sewer Line Connection to Existing Manhole

A. Low Depths of Flow

When the depth of flow in the existing sewer pipe is low (less than 2.5 inches), a flow-through plug may be installed in the upstream line and the upstream manhole(s) shall be monitored.

B. Moderate and Low Depths of Flow

When the depth of flow in the existing sewer line is moderate (2.5 inches to 60% depth of flow), a flow-through plug may be installed during the connection and during the construction. A second available option is to install a plug inside the upstream existing sewer line with pumping at the upstream manhole(s). The pumping measures may be reduced to monitoring with a standby pumping setup for low flows (less than 2.5 inches).

C. High Depths of Flow

When depths of flow in the existing sewer line is high (greater than 60% pipe depth), flow management options are limited to bypass pumping measures at the upstream manhole(s).

2.6.12 Sewer Line Repairs and Pipe Section Replacements

With the exception of a dry sewer line, any sewer line repair or the replacement of an existing pipe section (e.g. DIP replacements) shall require a plug to be installed in the upstream sewer line at the upstream manhole for pumping measures. A plug shall also be installed in the downstream manhole to protect the existing sewer system from receiving construction debris.

2.7 Formatting Requirements for Flow Management Plans

2.7.1 Simple Format FMP

Simple construction activities involving an existing small line may utilize a simple letter-format for the FMP. The submittal should include a signed cover letter with attached documents. The cover letter should meet the following requirements:

- A. Use the letterhead of the Contractor responsible for the wastewater flow management (add contact information if not included in letterhead);
- B. Identify the project name, plan number, permit number, project owner, location, and a brief description of the sewer-related construction;
- C. Identify the Department's manhole identification number for the manholes impacted by, or located immediately upstream and downstream, of sewer-related construction;
- D. Include a detailed description of the proposed measures for wastewater flow management and phasing, if applicable;
- E. Identify the estimated flows in the existing sewer line, the method of how these flows were estimated, and the dates and times of metering or observation;
- F. Identify the calculated design flows that the proposed measures were based on;
- G. Specify the type of disinfectant and required volume for incidental releases;
- H. Provide a schedule for sewer-related construction activities (e.g. dates and times for start, completion, normal working hours and variations for sewer-related construction);
- I. Include the following standard note to the Contractor: "Machine excavation shall not be conducted within two (2) feet of the top of sewer. Excavation within two (2) feet of the top of sewer shall be conducted by hand digging only. Any manhole frame and cover adjustments shall be conducted only after a flow channel cover per S.D. RWRD 306 has been properly installed to protect existing Public Sewers from receiving construction debris".
- J. Include the name, signature, title and contact information of the person responsible for implementing the FMP; and

- K. Include a Contractor's certification statement such as: "We have read, understand and will adhere to Section 2 of the Pima County RWRD Standard Specifications and Details for Construction 2021 for the preparation of Flow Management Plans".

A boiler-plate example of this cover letter is available from the Field Engineering section. Where applicable, the simple-letter format FMP should also meet the following requirements:

- L. Include a map per Subsection 2.7.4;
- M. Include spare pump calculations per Subsection 2.6.2;
- N. Include photos of existing manholes that are impacted by flow management activities. Photos shall be taken looking down into the manhole, clearly showing the flow channels and with north at the top of the photo. For each photo provide the date, time, and the Department's unique manhole identification number;
- O. Provide flow metering documents and calculations showing how existing flows and design flows were obtained;
- P. Include a customer notification plan in accordance with Subsection 2.8;
- Q. Include cut sheets for flow management equipment;
- R. Include a list of emergency contact numbers for the Contractor's staff responsible for maintaining wastewater flow management (i.e. project owner, superintendent, etc.); and
- S. Include a list of emergency contact numbers for Department staff (for verification and to be returned to Contractor).

2.7.2 Detailed Format FMP

Larger sewer construction activities that will involve existing large lines will require an FMP presented in a plan format and shall meet the following requirements:

- A. Submit plans on 24" x 36" sheets;
- B. Provide a simple-format FMP cover letter per Subsection 2.7.1;
- C. If phasing is proposed, provide a complete and detailed description of the flow management procedures and their order of phasing;
- D. Specify the required procedures for sealing and testing the proposed pumping or gravity bypass system to prevent leakage;
- E. If either pumping or gravity bypass measures are proposed, use a minimum scale of 1" = 40' (plan) and 1" = 4' (profile) on all sheets;
- G. If gravity bypass measures are proposed, include all existing utilities in the vicinity of excavation on all plan sheets;

- H. Include a Map of Flow Management Measures per Subsection 2.7.4;
- I. Provide a separate detail for temporary pumping and diversion manholes; detail should emphasize the piping cutout location and dimensions, isolation gates and spacing between suction lines;

The specifications for a FMP shall meet the following requirements:

- K. Include all required attachments for a simple format FMP, with the exception of the map requirements per Subsection 2.7.4;
- L. If isolation gates will be used, include structural calculations sealed by an Arizona Registered P.E.;
- M. If pumping measures will be used, include calculations for the minimum required sump depth in the manhole sealed by an Arizona Registered P.E.;
- N. Include pump performance curves with system curve and duty points shown;
- O. Show that NPSHA substantially exceeds the NPSHR to avoid cavitation;
- P. If gravity bypass measures will be used, include a hydraulic analysis for these measures sealed by an Arizona Registered P.E.;
- Q. If pumping or gravity bypass measures will be used, include a capacity analysis, sealed by an Arizona Registered P.E., of the existing sewer lines that will receive additional flows and include the maximum flow depths that will occur in the existing sewer lines, manhole flow channels and service laterals (HCS/BCS);
- R. If odor control measures will be used, include a detailed description of this requirement and specifications;
- S. Include a list of equipment and identify the primary and backup equipment that will be kept onsite;
- T. Include an equipment maintenance and inspection plan with sample inspection logs for the required daily inspections of installed flow management facilities;
- U. Provide provisions to ensure pneumatic pipe plugs will be closely monitored;
- V. Include a description of security measures for personnel and equipment during flow management measures and outside standard work hours as appropriate;
- W. Include a description of the proposed measures for keeping local residents and businesses informed of service interruptions and the status of construction. On certain projects, the Contractor may be required to coordinate with the Department's public relations group for customer notifications;
- X. Include a Sanitary Sewer Overflow Spill Prevention Plan per Subsection 2.7.5.

2.7.3 Wastewater Flow Data

The FMP shall provide the following information in either a table or at each manhole:

- A. For metered flows, show the peak dry weather flows, dates of metering, and note any wet weather conditions, if applicable;
- B. For instantaneous flow observations, show the estimated peak dry weather flow with the assumed pipe depth (e.g. half-flow or full-flow) and note any wet weather conditions, if applicable; and
- C. Show the available capacity of the downstream sewer lines that will convey bypass flows during sewer construction.

2.7.4 Map of Flow Management Measures

The FMP shall include a map that clearly depicts the area of sewer-related construction, along with the proposed layout for flow management measures. This map shall clearly and legibly show the following information:

- A. Existing Public Sewers in the vicinity of the flow management activities;
- B. The type of plugs required and the locations where they are to be installed; and
- C. Street address and location of service laterals (HCS/BCS) that will be affected by construction.

In some cases, a copy of the Pima County PimaMaps with clear and legible hand-written annotations may be acceptable.

2.7.5 Sanitary Sewer Overflow Spill Prevention Plan

The Contractor shall be responsible for insuring there will be no unauthorized discharges or spills of raw sewage during construction. For construction that will impact large sewer lines, the Contractor shall also prepare a Spill Prevention Plan in the event of a flow management failure and a sanitary sewer overflow (SSO). The SSO Spill Prevention Plan shall be included with the submittal of the FMP for review and approval by the Department.

The Contractor shall install containment measures for incidental spills at pumps, valves and manifolds. These measures may be accomplished by constructing earthen berms along the perimeter of the equipment's staging area and lining that area with a single sheet of polyethylene plastic sheeting or other approved material. Berms shall be a minimum height of 6-inches and the sheeting material shall have a minimum thickness of 35 mils. The use of a portable spill containment setup may also be permitted when Approved by the Field Engineering Manager. .

The Contractor shall store 12.5% sodium hypochlorite solution (NaOCl) near each pumping setup for the disinfection and cleanup of incidental spills. For sewer lines 12 inches in diameter or less, the minimum required volume of NaOCl shall be 6 gallons. For sewer lines greater than 12 inches in diameter, the minimum volume

shall be 50 gallons. Storage containers for this solution shall be sealed securely at all times to prevent off-gassing. Unsealed containers shall be replaced immediately with fresh solution. These measures are not intended for an SSO.

In the event of an SSO, the Contractor shall immediately notify the Field Engineer and Department's Conveyance Division. For weekends, Holidays or between 5:00 pm and 8:00 am, the Contractor shall immediately call the Pima County Sheriff's Communication Center and request a Department representative to be dispatched to the site.

The Contractor shall take immediate action to prevent or contain an SSO. The Contractor shall be responsible for all costs to repair the system, for all expenses to mitigate the release and to disinfect the release areas, and for any regulatory penalties levied on the Department.

The Contractor shall repair all damage to the satisfaction of the Director. In cases where the Contractor is not in compliance with mitigation efforts, any assistance provided by the Department will be billed to the Contractor. The Contractor shall compensate the Department for the cost of any fines levied as the result of an SSO.

2.8 Customer Notifications for Service Interruptions

The FMP shall also include a customer notification plan that shall address, at a minimum, all of the following requirements:

1. Identify all customers that may experience service interruptions or any other disturbances during construction and describe why these cannot be avoided;
2. Describe how customer notifications for service interruptions or disturbances will be carried out by the Contractor;
3. Describe the mitigation methods proposed by the Contractor for service interruptions or disturbances; and
4. Include specific time frames for service interruptions or disturbances.

The customer notification plan shall be reviewed and approved by the Department's public relations group, prior to construction.

The Contractor shall be responsible for locating all service laterals (HCS/BCS) that will be affected by construction and shall identify any services with the potential for high flow rates or other non-typical flow characteristics. The Contractor should contact the Department's GIS section to obtain all available records regarding the location of existing service laterals. If location records are not available, the Contractor shall locate existing service laterals through such methods as CCTV, dye testing or locating private cleanouts.

The Contractor shall make every possible effort to notify, in person, all sewer customers that will be affected by proposed construction and shall promptly respond to any questions or concerns. The Contractor shall make arrangements for at least one neighborhood meeting a minimum of ten (10) Calendar Days prior

to construction to address sewer-related issues. The Contractor's superintendent and at least one staff member from the Field Engineering section shall attend these meetings. The neighborhood meetings shall be a dialogue between the Contractor, the Department and the public to cover the following items, at a minimum:

5. Describe the parameters of the Project and how proposed construction will affect service to sewer customers;
6. Identify any special requirements or specific needs from the public;
7. Exchange contact information for any questions or concerns; and
8. Provide an opportunity for questions and answers.

At least 72 hours in advance, the Contractor shall also distribute door hanger pamphlets to all sewer customers to be affected by proposed construction. Each pamphlet shall be typed in both English and Spanish and shall describe the scope of the work, methods of construction and the dates and times that any interruptions in service may occur.

The Contractor shall also re-confirm with all customers at least 24 hours prior to the scheduled interruption in their service. The 24 hour notification shall require the Contractor to attempt to contact each customer verbally (i.e. by phone call or in-person) and also distribute an "Official Notification" that has been approved by the Department's public relations group. The Contractor shall maintain a customer notifications log to track the notification attempts for each customer. This log shall include the customer names, dates and times of each attempt, and the type of notification (e.g. verbal or door hanger pamphlet). A copy of the customer notification log shall be submitted to the Field Engineering section prior to the interruption in service.

For customers with interrupted sewer service, the Contractor shall provide portable sanitary facilities during the entire period of interruption. The required number of portable sanitary facilities shall not be less than one portable facility per two residences and one portable facility per each business. The Contractor shall be responsible for cleaning and maintaining these facilities. The Contractor shall accommodate any special requirements or specific needs for these customers (e.g. ADA compliance). If the period of any service interruption exceeds 24 hours, the Contractor shall provide temporary bypass pumping systems for these services.



SECTION 3 **STANDARD SPECIFICATIONS**

Standard Specifications and Details for Construction

TABLE OF CONTENTS

<u>SECTION</u>	<u>PAGE</u>
STANDARD SPECIFICATIONS	3-1
3.1 Earthwork.....	3-1
3.1.1 Description.....	3-1
3.1.2 Materials	3-1
A. Crushed Stone.....	3-1
B. Sand.....	3-1
C. Excavated Native Material.....	3-2
D. Select Import Material.....	3-2
E. Controlled Low-Strength Material (CLSM).....	3-2
F. Recycled Asphalt Product (RAP) and Lime.....	3-3
3.1.3 Construction Details.....	3-3
A. Trenches and Embankments.....	3-3
B. Foundations	3-3
C. Bedding.....	3-4
D. Haunching and Shading	3-4
E. Backfill.....	3-5
F. Backfill Density Testing Procedures	3-5
G. Stabilized Surface Treatment for Public Sewer Easements.....	3-8
3.2 Sanitary Sewer Pipe.....	3-8
3.2.1 Description.....	3-8
3.2.2 Materials	3-8
A. General	3-8
B. Vitrified Clay Pipe (VCP).....	3-8
C. Polyvinyl Chloride (PVC) Pipe	3-8
D. Ductile Iron Pipe (DIP).....	3-9
E. High-Density Polyethylene (HDPE) Pipe.....	3-10
F. Fiberglass Reinforced Pipe (FRP).....	3-10
G. Reinforced Concrete Pipe (RCP)	3-13
H. Cured-In-Place Pipe (CIPP).....	3-14
3.2.3 Construction Details.....	3-18
A. Survey Requirements	3-18
B. Installation of Pipe	3-19
C. Service Lateral (HCS/BCS) Connections	3-25
D. Sewer Line Testing and Tolerances	3-27
E. Markers.....	3-34
F. Modifications and Repairs	3-35
G. Abandonment of Pipe	3-35
3.3 Sanitary Sewer Manholes.....	3-35
3.3.1 Description.....	3-35

3.3.2	Materials	3-36
A.	Concrete	3-36
B.	Reinforcing Steel	3-36
C.	Grout and Mortar	3-36
D.	Water	3-36
E.	Precast Concrete Manhole Sections	3-36
F.	Interior Corrosion Resistance	3-37
G.	Steps.....	3-37
H.	Frames, Covers and Hatches.....	3-37
I.	Flexible Joint Gaskets.....	3-38
3.3.3	Construction Details	3-38
A.	Excavation and Backfill.....	3-38
B.	Installation of Manholes	3-38
C.	Manhole Installation Testing and Tolerances	3-42
D.	Modification of Existing Manholes	3-43
E.	Abandonment of Manholes.....	3-47
3.4	Other Sanitary Sewer Appurtenances.....	3-47
3.4.1	Piles.....	3-47
3.4.2	Casing Pipe	3-48
3.4.3	List of Approved Products for Public Sewers.....	3-48

Section
3

Standard Specifications

3.1 Earthwork

3.1.1 Description

Any Work under the *Standard Specifications and Details* shall consist of performing all operations necessary to excavate all materials, regardless of character and subsurface conditions; to excavate trenches for Public Sewers; to excavate all materials necessary for the construction of Public Sewer manholes and other structures; to place backfill for Public Sewer lines; to backfill holes, pits and other depressions; to remove and replace unsuitable material; and compaction requirements. These operations shall be performed in accordance with the lines, grades and typical sections designated in the Sewer Plans and the *Standard Specifications and Details* unless otherwise approved by the Field Engineer.

3.1.2 Materials

A. Crushed Stone

Crushed stone shall conform to the requirements of Table 1 in S.D. RWRD-104. This material shall consist of durable particles of crushed stone free of silt, clay, or other unsuitable material, and have a percentage of wear of not more than 40% when tested in accordance with ASTM C131 or C535. When material is subjected to five cycles of the sodium sulfate soundness test in accordance with ASTM C88 - Sodium Sulfate Solution, the weighted percentage of loss shall not exceed 12%. Additional tests for pH and minimum resistivity, in accordance with Arizona Test Method 236b, shall be required for sewer lines where ductile iron pipe and/or ductile iron fittings are used. The value of resistivity shall not be less than that for the existing in-place material or 2,000 ohm-cm.

Prior to the start of construction, documentation for materials testing shall be certified for conformance and submitted to the Field Engineer. When this material is obtained from excavation or a source selected by the Contractor, it must be Approved by the Field Engineer and require documentation for materials testing by a third party Geotechnical Engineer.

B. Sand

Sand shall conform to the requirements of Table 1 in S.D. RWRD-104. Additional tests for pH and minimum resistivity, in accordance with Arizona Test Method 236b, shall be required for sewer lines where ductile iron pipe and/or ductile iron fittings are used. The value of resistivity shall not be less than that for the existing in-place material or 2,000 ohm-cm.

Prior to the start of construction, documentation for materials testing shall be certified for conformance and submitted to the Field Engineer. When this material is obtained from excavation or a source selected by the Contractor, it must be Approved by the Field Engineer and require documentation for materials testing by a third party Geotechnical Engineer.

C. Excavated Native Material

Excavated native material used for backfill shall conform to the requirements of Table 1 in S.D. RWRD-104. This material shall not contain organic material, rubbish, debris or deleterious material. It shall not contain rocks, frozen earth or solid material larger than 6 inches in greatest dimension. Excavated material shall be well-graded and capable of meeting the compaction requirements of Subsection 3.1.3(F). Additional tests for pH and minimum resistivity, in accordance with Arizona Test Method 236b, shall be required for sewer lines where ductile iron pipe and/or ductile iron fittings are used in conjunction with the rigid pipe trench detail, per S.D. RWRD-104. The value of resistivity shall not be less than that for the existing in-place material or 2,000 ohm-cm.

Excavated material from an offsite source selected by the Contractor must be Approved by the Field Engineer and require documentation for materials testing certification by a third party Geotechnical Engineer.

D. Select Import Material

Select import material shall conform to the requirements of Table 1 in S.D. RWRD-104. This material shall not contain frozen lumps, rocks larger than 3 inches in diameter, chunks of clay or other objectionable material. Additional tests for pH and minimum resistivity, in accordance with Arizona Test Method 236b, shall be required for sewer lines where ductile iron pipe and/or ductile iron fittings are used in conjunction with the rigid pipe trench detail per S.D. RWRD-104. The value of resistivity shall not be less than that for the existing in-place material or 2,000 ohm-cm.

Prior to the start of construction, documentation for materials testing shall be certified for conformance and submitted to the Field Engineer. When this material is obtained from excavation or a source selected by the Contractor, it must be Approved by the Field Engineer and require documentation for materials testing by a third party Geotechnical Engineer.

E. Controlled Low-Strength Material (CLSM)

Materials comprised of CLSM shall conform to the requirements of Section 1006 of the *PAG Standard Specifications*. CLSM mix designs shall conform to Section 501-2.04 of the *PAG Standard Specifications*, unless otherwise indicated in the Sewer Plans, or as directed by the Field Engineer.

F. Recycled Asphalt Product (RAP) and Lime

The use of recycled asphalt product or lime for trench materials and other sewer construction is prohibited.

3.1.3 Construction Details

A. Trenches and Embankments

The Contractor shall comply with all OSHA regulations pertaining to trenching operations. When used, trench boxes shall be positioned so that the compaction of trench material is not compromised when the box is advanced with work in progress. The inside walls of the box should be at least two pipe diameters clear on each side of the sewer pipe.

In regards to the completion of backfill operations prior to the end of the Contractor's work day, the maximum length of open trench for all installations shall be either 500 feet, or the Contractor's daily installation length, whichever is greater.

Trench widths for sewer lines installations shall conform to S.D. RWRD-104, unless otherwise noted in the Sewer Plans. The completed trench bottom shall be firm for its full length and width.

In special cases, the Sewer Plans may specify either a longitudinal camber or longitudinal arch along the trench bottom to compensate for the anticipated settlement of the sewer pipe. In such cases, special provisions for grade staking and alignment verification/testing shall be included in the Sewer Plans.

In cases where groundwater is encountered, the method of dewatering shall be determined on a case-by-case basis. In any case, the Contractor shall submit to the Field Engineer, a dewatering plan and a Stormwater Pollution Prevention Plan (SWPPP) for review and Approval, prior to the start of construction. Any modification due to variable soils or groundwater encountered during construction shall be forwarded to the Field Engineer.

If the ground surface elevation over any portion of an existing sewer line will be reduced so that the cover is less than 4 feet, the Contractor shall replace the reach pipe as stipulated in Section 5.1.7 of the *Engineering Design Standards*. This standard applies during construction, where the lowest elevation attained may be less than the finish grade. It also applies to the reconstruction of streets, the re-grading of Public Sewer easements or any other excavation where the existing sewer line will be subjected to additional loads by heavy trucks or compaction equipment.

B. Foundations

A modified trench foundation is required only when the native soil in the trench bottom does not provide a firm working platform for placement of bedding material, as described in the following cases.

Where rock, hardpan or other unyielding material is encountered at the trench bottom, such material shall be removed at least 12 inches below the trench bottom or as directed by the Field Engineer. The width to be removed shall conform to S.D. RWRD-104 or as indicated in the Sewer Plans, and maintained throughout the over-excavation. The over-excavated material shall be replaced with an Approved foundation material in accordance with S.D. RWRD-104.

Where unsuitable material is encountered that causes the trench bottom to be unstable, the unsuitable material shall be removed to a depth as specified by a Geotechnical Engineer. The width to be removed shall be the width of the trench, as shown on S.D. RWRD-104 or as indicated in the Sewer Plans, and maintained throughout the over-excavation. The over-excavated material shall be replaced with an Approved foundation material in accordance with S.D. RWRD-104.

Foundation material shall be compacted in layers, not exceeding 6 inches in depth, to at least 95% of the maximum dry density and optimum moisture content determined in accordance with the requirements of the applicable test methods of the ADOT Materials Testing Manual or as specified by the Geotechnical Engineer.

C. Bedding

Prior to the placement of bedding material and pipe, all trash, forms, sheeting, bracing and loose rock or loose earth shall be removed from the trench. The thickness of bedding material shall be in accordance with S.D. RWRD-104. Bell holes shall be provided at each pipe joint to permit proper assembly and support of the pipe.

D. Haunching and Shading

Haunching and shading material shall be the same material as that used for bedding.

Haunching shall be completed as the pipe is laid and placed up to the pipe's Springline (50% of the pipe's diameter). The shovel slicing technique shall be used to ensure material is placed under the haunches of the pipe to reduce voids and increase pipe support.

Shading material shall be placed in a manner which will prevent distortion of, damage to, or displacement of the pipe from its horizontal and vertical alignments. Shading material shall be placed over the haunching and pipe to a minimum of 12 inches above the top of the pipe and extend horizontally to the interior walls of the trench.

Haunching and shading material shall be compacted to 95% standard proctor, in accordance with the requirements of the applicable test methods of the *ADOT Materials Testing Manual*, as directed and Approved by the Field Engineer, unless otherwise noted in the Sewer Plans. Compaction through water settling or jetting is not permitted.

E. Backfill

Prior to placement of backfill material, all trash, forms, sheeting, bracing, loose rock or loose earth shall be removed from the trench.

Backfill material shall be compacted in lifts to attain a minimum of 95% standard proctor, in accordance with the requirements of the applicable test methods of the *ADOT Materials Testing Manual*, as directed and Approved by the Field Engineer, unless otherwise noted in the Sewer Plans. Backfill material and compaction shall also conform to the requirements of the Agency having jurisdiction of the Right-of-Way in which Public Sewers are being installed.

Compaction through water settling or jetting is not permitted. Backfill shall not be wheel loaded until 3 feet of cover is provided over the top of the pipe.

Failure of backfill compaction test results will result in rejection of that portion of the pipe installation. Replacement of trench materials and pipe will be at the Contractor's expense.

F. Backfill Density Testing Procedures

Additional density testing procedures for the compaction of backfill shall be provided for sewer construction projects meeting any of the following criteria:

- A cumulative total of 500 LF or more of new Public Sewer lines;
- The depth of either trench excavation or cover is greater than 20 feet;
- The geotechnical report, soil borings or historical records indicate a potential for the presence of groundwater; or
- The Department deems that site soil conditions warrant a geotechnical oversight (e.g. difficult to process soil type).

Density testing services shall be provided by a Geotechnical Engineer. Contact information for the Geotechnical Engineer and the field technicians working under his direction, shall be provided to the Field Engineer at the pre-construction meeting.

The Contractor shall continuously review density test results during backfill activities. Successive lifts of backfill shall not be placed until density test results show conformance to compaction requirements. Failure by the Contractor to adhere to these requirements will result in suspension of inspection by the Department and cancellation of the construction permit.

It is option of the Contractor to select either Procedure A or Procedure B for the density testing of backfill. Each procedure is described in the following Subsections.

i. Procedure A

The Geotechnical Engineer shall prepare and seal a *Geotechnical Quality Control Plan* (GQCP). The GQCP shall include the following:

- Project information;
- Quality Control Organization;
- Resumes;
- AASHTO Laboratory Certificate; and
- Control Procedures (i.e. moisture and density per lift).

The GQCP shall specify the minimum frequencies of random density and moisture tests to be performed for the Project and shall meet the minimum testing requirements of Subsection 3.1.3(F). It shall be submitted to the Field Engineering section for conformance review. A written notice to proceed will be issued by the Field Engineering section when the GQCP is Approved.

The applicable density test method will be dictated by the variability of backfill material to ensure proper compaction values are recorded.

The Contractor and the Geotechnical Engineer shall be equally responsible for ensuring proper backfill compaction is accomplished. Daily density testing results shall be made available upon request to the Contractor and the Field Engineer. Density test results shall meet or exceed minimum compaction requirements and shall be submitted to the Field Engineer on a weekly basis.

Density testing procedures shall conform to the following requirements:

- (1) Perform random density and moisture tests in accordance with the GQCP (additional tests may be performed at any given location at the discretion of the Geotechnical Engineer).
- (2) Perform a visual inspection of the trench bottom and check for unsuitable materials. If unsuitable material is encountered, it shall be over-excavated and replaced as directed by the Geotechnical Engineer.
- (3) Trench Backfill:
 - Density testing of trench backfill shall commence at approximately 2 feet above top of sewer pipe and continue to the base of the roadway structural section, or to the base of the stabilized surface, as applicable; and
 - For each sewer reach installed, a minimum of one density test shall be taken at every vertical 2 feet of backfill between manholes, or one every 300 feet, whichever is shorter. The field technician shall conduct backfill density tests randomly, both horizontal and vertical, in accordance with the GQCP. These tests shall provide a representation of the compacted effort throughout the sewer reach length.

- (4) Perform a visual inspection of each manhole base and check for unsuitable materials. If unsuitable material is encountered, it shall be over-excavated and replaced as directed by the Geotechnical Engineer. Where over-excavation and replacement under a proposed structure base is required, a minimum of one density test shall be taken at the approximate center of the proposed structure, or as directed by the Geotechnical Engineer.
- (5) Density testing for backfill around manholes shall consist of one test per lift, and rotating with successive 2-foot increments at 120 degree intervals. Density testing of backfill around formed structures shall require one test per lift, alternating sides with successive 2-foot increments as instructed by the Geotechnical Engineer and in accordance with the GQCP. Density tests will be taken as close as possible to the structure to determine the representative compaction density, but not so close as to interfere with the functioning of the testing equipment.

Upon completion of sewer construction and prior to issuance of the ECC, the Geotechnical Engineer shall provide the Field Engineer with a *Final Compaction Report* (FCR) for review and approval. The FCR shall be certified with a cover letter and include all test data (i.e. re-tests, calibration tests, and test methods) and a map showing testing locations, referenced by station, depth below grade and percent compaction achieved. The Geotechnical Engineer shall also include a statement confirming that the FCR meets the original requirements of the GQCP.

Under the provisions of the compaction testing requirements herein, geotechnical oversight by the Geotechnical Engineer shall be taken to include review of the Sewer Plans, development of the GQCP and the FCR, supervision of and coordination with the field technician(s) performing compaction testing, and review of test results for compliance.

ii. Procedure B

The Geotechnical Engineer shall provide a full-time field technician, working under his/her direction, for observation and collection of the density testing results for sewer construction.

Density testing results meeting or exceeding minimum approved Project requirements shall be demonstrated through a *Daily Observation and Testing Report* (DOTR) prepared by the field technician. The Contractor and Geotechnical Engineer shall effectively communicate density test results to ensure proper backfill compaction is accomplished. The DOTR shall be made available to the Field Engineer and the Contractor by the end of each day.

Upon completion of sewer construction, the Geotechnical Engineer shall compile all DOTRs into a complete package. This package shall also include a sealed cover letter stating that backfill density testing procedures were adhered to in accordance with the Department's requirements.

G. Stabilized Surface Treatment for Public Sewer Easements

Stabilized surface treatment for Public Sewer easements shall conform to S.D. RWRD-111, unless otherwise indicated in the Sewer Plans.

3.2 Sanitary Sewer Pipe

3.2.1 Description

The work under Subsection 3.2 shall consist of furnishing and installing sanitary sewer pipe, and all other appurtenant materials required, including excavation and the furnishing, placing and compacting of bedding and backfill material, all in accordance with the details shown in the Sewer Plans and the requirements of the *Standard Specifications and Details*.

3.2.2 Materials

A. General

At each location where a pipe is to be installed, the pipe material, diameter and length, along with the requirements for each approved option at that location, such as wall thickness, coatings, lining, class and strength, shall be in accordance with the Sewer Plans.

Certification documents from the manufacturer shall be furnished attesting that the pipe and appurtenances (excluding linings and coatings if applied by an independent applicator) meet the requirements set forth in the *Standard Specifications and Details*. All pipe and appurtenances shall be clearly marked with the name or trademark of the manufacturer, the batch number, and the location of the manufacturing plant.

B. Vitrified Clay Pipe (VCP)

VCP shall be new and extra strength. All materials, manufacture and testing for VCP shall meet the requirements of ASTM C700, C1208, ASTM C896, ASTM C301 and ASTM C425.

C. Polyvinyl Chloride (PVC) Pipe

Except as modified herein, all materials, manufacture and testing for PVC gravity sewer pipe and fittings shall conform to ASTM D3034 for diameters of 4 through 15 inches and ASTM F679 for diameters of 18 inches and larger. PVC gravity sewer pipe shall be SDR 35 unless otherwise shown in the Sewer Plans.

PVC gravity sewer pipe shall have a minimum pipe stiffness of 46 psi at 5% deflection, in accordance with ASTM D2412.

PVC gravity sewer pipe and fittings shall be made of PVC plastic having a cell classification of 12454 or 12364, as defined in ASTM D1784. Additives and fillers,

including, but not limited, to stabilizers, antioxidants, lubricants, colorants, etc., shall not exceed 10 parts by weight per 100 parts of PVC resin in the compound.

PVC gravity sewer pipe joints shall be gasketed, bell-and-spigot, push-on type, conforming to ASTM D3212. Because each pipe manufacturer has a different design for push-on joints, gaskets shall be part of a complete pipe section and purchased as such. Gaskets shall conform to ASTM F477 and be factory-installed and locked-in. Lubricant shall be as recommended by the pipe manufacturer.

Standard laying lengths for PVC gravity sewer pipe shall be 14 feet.

Service connections shall be installed with "Tee" or "Wye" fittings, gasketed "Tee" saddles with stainless steel bands, or other tapping devices as Approved by the Field Engineer. Solvent welded "Wye" saddles are not Approved.

All fittings and couplings shall be compatible with the pipe to which they are attached and have an approved interior corrosion protection.

Pipes or fittings may be rejected by the Field Engineer for failure to comply with the requirements herein.

D. Ductile Iron Pipe (DIP)

All materials, manufacture and testing for DIP shall be in accordance with ASTM A746 and the latest revision of ANSI/AWWA C151/A21.51. Each pipe shall be subjected to a hydrostatic pressure test of at least 500 psi at the point of manufacture. DIP shall be manufactured in nominal 18 or 20-foot laying lengths.

DIP shall have standard asphaltic coating on the exterior, unless otherwise specified in the Sewer Plans.

DIP shall have an Approved Cured-In-Place Pipe (CIPP) on the interior. See Sub-section 3.2.2.H for CIPP specifications.

The following information shall be clearly marked on the exterior surface of each piece of DIP:

- Name or trademark of pipe manufacturer ;
- Pipe material "DI" or "Ductile";
- Pressure class or thickness class;
- Date and country of pipe casting and;
- Lot or Serial number;

All gravity sewer pipe shall be furnished with push-on type joints, such as Tyton® or Fastite®. Joints shall conform to the latest revision of ANSI/AWWA C111/A21.11, and shall be furnished complete with all required accessories. EPDM gasket material shall be used for all DIP, unless otherwise specified in the Sewer Plans.

Fittings shall be ductile iron and shall conform to the latest revision of either ANSI/AWWA C110/A21.10 or ANSI/AWWA C153/A21.53. Fittings and accessories shall be furnished with either push-on or mechanical type joints in accordance with to the latest revision of ANSI/AWWA C111/A21.11.

Polyethylene wrap in tube or sheet form for piping encasement shall be manufactured from virgin polyethylene material and marked in accordance with the requirements of ANSI A21.5, ASTM D4976 and AWWA C105. The minimum thickness shall be 8 mils.

E. High-Density Polyethylene (HDPE) Pipe

HDPE pipe shall be manufactured from extra high molecular weight polyethylene material, meeting the requirements of Type III, Class C, Category 5, Grade P34, as defined in ASTM D1248. The pipe material shall meet the requirements of cell classification PE345464C or PE345464E of standard polyethylene code designation PE3408, as defined by ASTM D3350. The manufacturer shall certify that the pipe material has been tested, in accordance with the provisions of ASTM F1473, for greater than 100 hours without failure. The manufacturer shall also certify that the pipe has a hydrostatic design basis of 1,600 psi at 73° F and 800 psi at 140° F, when tested in accordance with the provisions of ASTM D2837.

HDPE pipe shall have a controlled outside diameter and manufactured to the SDR/DR rating and inside diameter specified by the Sewer Plans. The pressure rating of HDPE pipe shall be in accordance with ASTM D3035 and ASTM F714.

Fittings shall be manufactured using the same pressure rating as the designed piping system. Fittings shall have a controlled outside diameter and the SDR/DR rating for the pressure specified by the Sewer Plans. Fittings shall be specifically manufactured to standardized dimensions noted in the Sewer Plans.

Butt fusion fittings shall be manufactured from the same material as the extruded pipe, shall be rated for a pressure service equal to at least that for the system pipe, and shall have outlets manufactured to the same DR as the system pipe. Molded fittings shall be manufactured in accordance with ASTM D3261 and socket fittings shall be manufactured in accordance with ASTM D2683.

The pipe manufacturer shall have 5 years minimum experience in producing HDPE pipe. The pipe manufacturer shall maintain a continuous quality control program. HDPE pipe and fittings for a project shall be manufactured from the product of a single, approved manufacturer.

A Certificate of Compliance shall be provided by the pipe manufacturer that the HDPE pipe and fittings conform to the requirements of Subsection 3.2.2(E).

F. Fiberglass Reinforced Pipe (FRP)

Except where modified in the *Standard Specifications and Details*, all materials, manufacture and testing for FRP pipe shall conform to ASTM D3262, ASTM

D3681-01, ASTM D4161 and ASTM D2412. The minimum pipe stiffness when tested in accordance with ASTM D2412, shall be 46 psi.

The pipe manufacturer shall maintain a continuous quality control program. FRP pipe shall be manufactured from only polyester resin systems with a proven history of performance in the application of gravity sewer pipe installations. The historical data shall have been acquired from material(s) of similar construction and composition as the proposed product.

The reinforcing glass fibers used to manufacture the components shall be of the highest quality commercial grade E-glass filaments with binder and sizing compatible with impregnating resins.

Sand shall be a minimum of 98% silica with a maximum moisture content of 0.2%.

When used, resin additives, such as curing agents, pigments, dyes, fillers, and thixotropic agents shall not detrimentally affect the performance of the product.

Gaskets shall be suitable for the service intended, conform to ASTM F477, and be supplied by a qualified gasket manufacturer.

The pipe shall be manufactured using only the centrifugal-casting process, in order to produce a dense, non-porous, corrosion-resistant, uniform structure. The pipe shall meet the ASTM D3262 standard specification, Cell Limit Type 1, Liner 2 and Grade 3. The manufacturer of pipe and fittings must demonstrate a 10-year history of successful installations in the United States for sanitary sewer service.

Unless otherwise indicated in the Sewer Plans, the pipe shall be field connected with fiberglass sleeve couplings that utilize built-in double fin elastomeric sealing gaskets made of EPDM rubber compound as the sole means to maintain joint water tightness. The joints must meet the performance requirements of ASTM D4161.

For sliplining and tunnel carrier installations, joints at tie-ins, may utilize fiberglass, gasket-sealed closure couplings.

For jacking installations, the joint shall have approximately the same outside diameter as the pipe. When the pipes are assembled, the joints are essentially flush with the pipe outside surface. Joints at tie-ins, may utilize fiberglass, gasket-sealed closure couplings.

The interior surface layer or liner shall consist of a highly flexibilized nominal 40 mil thick polyester resin with a minimum elongation of 50% when tested according to ASTM D638. Interior glass reinforced layers of pipe cannot be the corrosion barrier or liner finish. All pipes shall be tested per ASTM D3681 corrosion test using 1 N sulfuric acid and demonstrating a 0.90% or better strain for 100-year service life design.

Flanges, elbows, reducers, tees, wyes, laterals and other fittings, shall be capable of withstanding all operating conditions when installed. They may be contact

molded or manufactured from mitered sections of pipe joined by glass-fiber-reinforced overlays. Properly protected standard ductile iron, fusion-bonded epoxy coated steel and stainless steel fittings may also be used.

Reinforced fiberglass manhole tee base fittings shall be constructed of mitered sections of FRP connected with fiberglass reinforcement laminations. The diameter and length of the tee base through section, and the vertical leg shall be as shown in the Sewer Plans or as agreed between purchaser and supplier, as Approved by the Field Engineer. Pipes used to construct the tee base shall have the same stiffness as the line pipes, but not greater than 46 psi as a minimum requirement. Fabricate the tee base through section with a mitered elbow configuration to achieve the required angles shown in the Sewer Plans. Maximum angle of each miter is 30 degrees except individual alignment changes up to 35 degrees may be 1 miter. Construct drop configurations as shown in the Sewer Plans. Accommodate diameter changes at manholes using a reducer on the upstream side of the tee base. Assemble the tee base to the line pipes using the same gasket-sealed joint as pipe-to-pipe connections or another gasket-sealed joint as approved by the pipe manufacturer.

The actual outside diameter for pipe sizes ranging from 18-inches to 48-inches shall be in accordance with ASTM D3262. For other pipe sizes, the outside diameters shall be in accordance with the manufacturer's literature.

Pipe shall be supplied in nominal lengths of 20 feet. Actual laying length shall be nominal +1, -4 inches. At least 90% of the total footage of each size and class of pipe, excluding special order lengths, shall be furnished in nominal length sections.

For direct bury and sliplining installations, the minimum wall thickness shall be the stated design thickness.

For jacking installations, the minimum wall thickness is determined from the maximum jacking load. This thickness is measured at the bottom of the spigot gasket groove where the wall cross-section has been reduced. The minimum factor of safety against jacking force is 2.5, based on straight alignment.

Pipe ends shall be square to the pipe axis, with a maximum tolerance of 1/8".

The Field Engineer shall be entitled to inspect pipes or witness the pipe manufacturing.

Should the Field Engineer request to see specific pipes during any phase of the manufacturing process, the manufacturer shall provide the Field Engineer with adequate advance notice of when and where the production of those pipes will take place.

Packaging, handling, and shipping shall be done in accordance with the manufacturer's instructions.

G. Reinforced Concrete Pipe (RCP)

RCP for Public Sewers shall be circular and conform to the requirements of ASTM C76. The use of arch or elliptical RCP is not permitted. RCP shall have all of its interior surfaces lined with an Approved lining material or as Approved in the Sewer Plans. Refer to the Department's List of Approved Products for the recommended interior lining materials for RCP. RCP shall have a nominal laying length of 8 to 20 feet, unless otherwise Approved by the Field Engineer.

The wall thickness and reinforcing steel shall conform to ASTM C76 and the designated class of pipe as indicated in the Sewer Plans. When the designated class of pipe is not specified in the Sewer Plans, it shall be determined in accordance with the Concrete Pipe Design Manual by the American Concrete Pipe Association, latest edition. All jacking pipe shall be specifically designed by the pipe manufacturer to withstand all forces that the pipe may be subjected to during jacking operations.

All RCP shall be manufactured in accordance with ASTM C76 and C497, or as specified in the Sewer Plans. A letter from the supplier to the Field Engineer shall be submitted certifying that all RCP is manufactured in accordance with ASTM C76.

The manufacturer shall specify the maximum allowable joint gaps on all conduit sizes for the project and it shall be provided to the Field Engineer. The maximum allowable joint gap is determined as that point where the bevel of the bell and the shoulder of the spigot are vertically aligned and the rubber gasket has achieved the minimum compression necessary to ensure a water tight seal.

A production schedule shall be provided to the Field Engineer at least three Working Days in advance of when the various types of pipe will be cast, so that the casting operation may be inspected and appropriate specimens may be selected for testing in accordance with the Sewer Plans.

Type II Portland Cement complying with the requirements of ASTM C150 shall be used in the production of RCP unless otherwise indicated in the Sewer Plans or Approved by the Field Engineer.

Lifting anchors shall be used on all precast concrete pipe. Lifting holes are not allowed. The use of other lifting mechanisms proposed for handling and placement of RCP shall be submitted to the Field Engineer for Approval.

Details of all fittings and specials shall be submitted for Approval to the Field Engineer prior to construction. Fittings and specials shall be made up of pipe segments having the same structural qualities and the same interior treatment as the adjoining pipe.

Joints shall be formed using rubber gaskets that provide a watertight seal, in accordance with ASTM C443. Joints shall be capable of withstanding the forces caused by the compression of the gasket when joined.

Joints shall be either bell-and-spigot or tongue-and-groove styles. The spigot or tongue shall be grooved to properly contain and seat the rubber gasket. Joint assemblies shall be accurately formed so that when each pipe section is forced together in the trench, the assembled pipe shall form a continuous watertight conduit with a smooth and uniform interior surface. Joints shall provide for slight movement of any piece of the pipeline caused by expansion, contraction, settlement or lateral displacement. The gasket shall be the sole element of the joint providing water tightness. The ends of the pipe shall be perpendicular to the longitudinal centerline of the pipe, except where bevel-end pipe is required. The ends shall be finished so that they are uniform and smooth.

Rubber gaskets for bell-and-spigot joints shall consist of an O-ring rubber gasket, rubber profile gasket, or gasket conforming to the pipe manufacturer's specifications.

Gaskets may be either natural rubber or neoprene and shall conform to ASTM C443. All gaskets shall be stored in a cool place, preferably at a temperature of less than 70 degrees Fahrenheit. In no case shall gaskets be stored in the open or exposed to direct sunlight. No gasket that shown signs of deterioration, such as surface cracking or checking, shall be installed in a pipe joint. When the air temperature is 10 degrees F or lower, the gaskets shall be warmed to a temperature of 60 degrees Fahrenheit, for a period of 30 minutes, before being placed on the pipe.

In addition to all other requirements set forth in this specification, the following additions shall apply to RCP being jacked: Pipe shall be Class V, unless otherwise specified in the Sewer Plans; grouting nipples shall be spaced no more than 8 feet apart on the installed pipeline; and pipe shall include steel joint rings (bell-and-spigot) conforming to ASTM C361.

The following shall be clearly marked on the interior and exterior surfaces of the pipe:

- Name or trademark of pipe manufacturer;
- ASTM specification designation (C76);
- Class and size;
- Date of pipe manufacture;
- Lot or serial number;
- Name of lining applicator;
- Name of lining product;
- Thickness of lining; and Date of lining application.

H. Cured-In-Place Pipe (CIPP)

i. **Materials**

- 1) Proposed materials shall be suitable for use in the environment and conditions of the project.

- 2) All liner pipe, joints, and fittings shall be suitable for continuous service in sewage environments with 10% sulfuric acid at an average wastewater temperature of 84 degrees Fahrenheit.
- 3) The tube shall consist of one or more layers of a flexible needled felt or an equivalent nonwoven or woven material (such as fiberglass), or a combination of nonwoven and woven materials, capable of carrying the prescribed quantity of resin, withstanding the required installation pressures and curing process temperatures. The tube's materials of construction should be compatible with the resin system to be used on this project. The material should be able to stretch to fit irregular pipe sections, negotiate minor bends, and dimple at any service or branch connections. The tube shall contain no intermediate or encapsulated impervious elastomeric layers that would prevent the resin from migrating and filling the annular spaces between the host pipe and the cured liner. No materials shall be included in the tube that is subject to delamination in the cured CIPP.
- 4) The tube should be fabricated to a size that, when installed, will tightly fit the internal circumference and the length of the pipeline or conduit. Allowances should be made in its manufacture for the longitudinal and circumferential stretching that occurs subjected to the installation pressures, will meet or exceed the designed finish wall thickness throughout its length.
- 5) The resin system shall meet the requirements of ASTM F1216, Section 5.2 except as modified herein. In addition, the resin shall be high-grade corrosion resistant specifically designed for CIPP installation. The wall color of the interior pipe surface of the CIPP after installation shall not be of a dark or non-reflective nature that could inhibit proper closed circuit television inspection. No fillers shall be added to the resin without the specific approval of PCRWRD.
- 6) The caulking/seal shall be of a resin mixture compatible with the CIPP and in accordance with the CIPP manufacturer's recommendations.
- 7) The tube shall be marked for distance at regular intervals along its entire length, not to exceed 5 feet. Such markings shall also include the CIPP System Manufacturer's name or identifying symbol (brand), the tube number, and pipe diameter.
- 8) Any plastic film applied to the tube on what will become the interior wall of the finished CIPP shall be compatible with the resin system used, translucent enough that the resin saturation is clearly visible, and shall be firmly bonded to the felt material. (Tubes with removable calibration tubes, such as those used in UV light-cured CIPP, do not have to meet this bonding requirement.)
- 9) The CIPP system used must have a minimum proven performance record of 250,000 LF of successful CIPP installation in the United States. Refer to the RWRD List of Approved Products for accepted CIPP manufacturers.
- 10) A licensed Contractor must have successfully installed a minimum of 50,000 feet of CIPP liner in sewers. In addition, the contractor must have successfully installed an individual length of CIPP in excess of the longest length on the project. This qualifying experience must have been completed in the United States and within the past 5 years. The Contractor

Experience Form and the Superintendent Experience Form are required to be submitted to Field Engineering at the Pre-Construction Meeting.

ii. Structural Requirements

All liner pipe used to line DIP sewer shall be designed to have a minimum service life of 50 years. No design shall rely on bonding to the existing carrier pipe wall. The following design criteria shall be utilized to develop suitable structural design for the pipe.

- 1) Safety Factor: Pipe design shall incorporate a safety factor of 1.5.
- 2) Ovality: Percentage ovality of DIP pipe shall equal 5%.
- 3) Long-Term Modulus of Elasticity shall be 50% of the initial modulus of elasticity.
- 4) Flexural Strength: Shall have a minimum value of 4,500 psi.
- 5) Minimum Thickness - Shall be the Minimum Liner Thickness with the plastic coating or pre-liner tube excluded per PCRWRD approved design.

The following formula is to be used to determine the minimum CIPP thickness:

$$T_{\min} = D_o / 100$$

Where T = CIPP thickness in inches

D_o = Mean outside diameter of the CIPP in inches

iii. Tube Installation

The tube material shall meet the requirements of ASTM F1216, Section 5. The tube shall be sized for the final position in the pipe and shall be fabricated to a size that when installed will form to the internal circumference and length of the original pipe with no noticeable bulges or folds present. Allowance should be made for variations in internal pipe diameters and circumferential stretching during inflation. Stretching and cut of liner shall be within the range of the manufacturer's recommended tolerances. Should inserted liners at the beginning of the project indicate excessive bulges or folds, PCRWRD shall be permitted to request changes in the Contractor's tube fabrication to eliminate said defects.

iv. Submittals

Before commencing any work, the Contractor shall submit the following to Field Engineering at the Preconstruction Meeting:

- 1) Material Certifications: Certifications of the materials including the cell classifications, grades, types of resins, glass fibers, and all other materials used in the manufacture of the liner pipe.
- 2) Design Calculations: Complete calculations including list of parameters, all formulas and all other data which are necessary for the design of the liner pipe. Calculations submitted shall use a design

temperature of 73.4 (+/- 3.6) degrees Fahrenheit and shall include, but not be limited to: pipe stiffness (PS), Dimension Ratio (DR), flexural modulus, initial and long term (50 years) values of pipe deflection after installation, pipe bending strain, constrained buckling strength, ovality reduction factor, and allowable installation length. Drawings showing the cross sectional profile of the liner pipe wall and pipe joint details shall also be submitted.

- 3) **Manufacturer's Specifications:** Relevant information from the resin manufacturer shall include specifications, characteristics, properties, and methods of application. A written certification that the resin material complies with the required application, along with curing temperature, and duration of the temperature depending upon the sewer size and CIPP Liner thickness as determined for the project shall be submitted. A blanket letter shall not be sufficient in case of varying CIPP Liner thickness and lengths. This information shall be used during field inspection to verify that proper curing procedures are followed.
- 4) **Temperature/Time Logs Forms:** The Contractor shall submit the format of the curing Temperature/Time Log sheets for review and approval. At a minimum, the log shall contain the inversion number, the reach(es) included in the inversion, design liner thickness, manufacturer resin and liner used, and the date of the inversion. Information on the temperature range and cure times recommended by the resin manufacturer shall also be submitted for each run of CIPP installed.
- 5) **Previous CIPP Field Samples:** To verify past performance, the manufacturer shall submit a minimum of 5 test results from previous field installations of the same resin system and tube materials as proposed for the actual installation. These test results must verify that the CIPP physical properties as specified in these Specifications have been achieved in previous field applications. New resin systems can be used by obtaining prior approval from PCRWRD and arranging to have testing done in an independent testing lab utilizing the proposed resin system and tube materials to confirm that these same physical properties can be obtained. In case of a new resin system, only one test value shall be required. The previous field samples or the new resin system samples (as the case may be) shall be provided to PCRWRD as shop drawing submittals.
- 6) **Test Reports:** Submit certified copies of test reports on physical and chemical properties of the resin and flexible tube.
- 7) **Testing Requirements:** All CIPP samples shall be collected in accordance with these Specifications for each inversion or insertion marked with the date of inversion or insertion, and properly marked with the inversion or insertion number, once the sample is removed from the source. **The PCRWRD inspector must be present during all sample taking.** Tests shall be conducted by a laboratory certified to perform CIPP materials testing. Contact Field Engineering for pre-approved laboratories.
- 8) **Thickness:** It is the responsibility of the Contractor to demonstrate to the PCRWRD Field Engineer/Inspector that the CIPP liner wall

thickness measured from the flat plate sample, is not less than the minimum thickness as per PCRWRD approved design. If necessary, the Contractor shall do an additional liner insertion, approved by Pima County, to meet the minimum liner thickness specification requirement.

- 9) Chemical Resistance: The CIPP shall meet the chemical resistance requirements of ASTM F1216, Appendix X2. CIPP samples for testing shall be of tube and resin system similar to that proposed for actual construction. It is required that CIPP samples with and without plastic coating meet these chemical testing requirements.
- 10) Physical Properties: A minimum of one (1) sample of the CIPP from each insertion shall be tested for flexural strength and the flexural tangent Modulus of Elasticity in accordance with the latest version of ASTM D790, Procedure A. These tests shall be done utilizing the full thickness of the CIPP with the plastic coating or pre-liner tube removed. If the tests cannot be run on the full thickness of the CIPP in one test, then the testing laboratory shall coordinate with PCRWRD to determine what should be done.

v. CIPP Sample Collections

The Contractor shall prepare a minimum of 1 sample of the CIPP from each insertion of CIPP that is undertaken. The samples shall be restrained samples for diameters of CIPP less than 18"; and flat plate samples for diameters of CIPP 18" and larger. All CIPP samples shall be properly marked with the date of inversion or insertion and the inversion or insertion number, once the sample is removed from the source. The PCRWRD inspector must be present during all sample taking. Sample testing shall be compliance with ASTM F1216, Section 8, as applicable. The samples shall be tested for thickness and initial physical properties as per these Specifications. The PCRWRD inspector must be present during all sample taking. A certified copy of these test results shall be delivered within ten (10) days of the inversion to the PCRWRD Inspector.

If an additional liner is installed over an existing liner, the Contractor must utilize a procedure whereby the additional liner will adhere to the existing liner in a manner acceptable to PCRWRD. Methods of repair shall be proposed by the Contractor and submitted to PCRWRD PM for review and approval before proceeding with the repairs.

3.2.3 Construction Details

A. Survey Requirements

i. Survey Cut Sheets

The Contractor shall be responsible for providing survey cut sheets to the Field Engineer in an Approved format and prior to commencing with sewer construction activities. Survey cut sheets shall be sealed by an Arizona Registered Land Surveyor and include all grade stakes to be used for the construction of new Public Sewers. Survey cut sheets shall also include a description for any unusual

conditions, such as extra cuts, extra cover, and drainage. Any errors or omissions in the survey cut sheets that result in improper sewer construction shall not be the responsibility of the Department.

Any revisions to the Sewer Plans that may occur during the progress of construction shall require a re-submittal of the survey cut sheets to the Field Engineer.

ii. Construction Survey Stakes

Survey stakes, for the construction of Public Sewers, shall be provided on an appropriate offset line at no greater than 50-foot intervals along the sewer line. At least two survey stakes shall be provided for each manhole and one stake shall be provided for each HCS/BCS cleanout. Each stake shall be marked and match the data provided in the survey cut sheets. The distance and direction of the offset line (N, S, E or W) shall be shown in relation to the sewer line. For example, if the offset line is ten feet north of the sewer line, then the offset distance and direction shall be "10'N." Stationing shall begin at a known permanent point (such as a monument or property pin) and remain visible after completion of construction.

Survey stakes shall be offset far enough away from excavation to avoid being lost during excavation or cave-ins. It shall be the responsibility of the Contractor to immediately replace lost or damaged stakes.

The Contractor shall provide sufficient checks and verifications of the sewer line grades and alignments during construction to ensure that new Public Sewers are constructed within the allowable tolerances per Subsection 3.2.3(D)(vii).

B. Installation of Pipe

i. General

Sewer pipe and appurtenances shall be handled so as to ensure delivery to the trench in sound and undamaged condition. Sewer pipe shall be unloaded near the location at which it will be installed. Sewer pipe shall not be stored along residential streets for more than 10 days or along a business street for more than 3 days. The interior of the sewer pipe shall be thoroughly cleaned of foreign material before being lowered into the trench.

New sewer system construction shall commence from the downstream point and progress upstream.

Installation of sewer pipe shall be in finished trenches free of water and debris, with the spigot ends pointing in the direction of the flow. Each pipe shall be laid true to line and grade, with uniform support under the full length of the pipe.

Any adjustment of line and grade shall be made by excavating or filling under the pipe. Wedging or blocking under the pipe ends is prohibited.

When work is not in progress, open pipe ends shall be securely closed with an Approved pipe plug or end cap so that no water, earth, animals or other foreign objects will enter the pipe. If any debris is found in the pipe prior to testing, the pipe shall be cleaned by propelling a snug-fitting inflated ball, or other Approved device, through the pipe with water.

Pipes made from unlike materials shall be coupled together in accordance with S.D. RWRD-103.

ii. Vitrified Clay Pipe (VCP)

VCP shall be installed in accordance with ASTM C12 and the latest installation publications available from the National Clay Pipe Institute (e.g. Clay Pipe Engineering Manual).

After a sewer line reach (manhole-to-manhole) has been backfilled to finish grade, it shall be tested for excessive leakage in accordance with the applicable testing requirements of ASTM C828 or ASTM C1091.

iii. Polyvinyl Chloride (PVC) Pipe

PVC pipe shall be installed in accordance with ASTM D2321 and the latest installation publications available from the PVC Pipe Association (e.g. UNI-PUB-9 and UNI-B-6). Embedment requirements for PVC pipe shall conform to S.D. RWRD-104.

Care shall be taken during the transportation of the pipe to ensure that the tie-down methods do not damage or deflect the pipe. PVC pipe shall be delivered to the job site and stored on palletized units, not to exceed 40 inches in height. Stacking of palletized units at the job site shall not exceed 8 feet in height. PVC pipe shall not be removed from the pallet or laid out along the ditch more than 24 hours prior to installation in the trench.

In addition to the tests at the manufacturer's plant, the Field Engineer may require that tests be performed on pipe specimens selected at random at the point of delivery or at the job site. The Department will bear the costs of such tests that shall be in accordance with ASTM D2412 and D2444.

Any imperfections, which, in the opinion of the Field Engineer, may adversely affect the performance of the pipe or joints, shall be cause for rejection of the PVC pipe.

All surfaces of the joint, upon which the gasket may bear, shall be smooth and free of any imperfection that could adversely affect sealing ability. All pipes shall have a "stop-mark" on the spigot end to indicate proper penetration when the joint is made. Pipes at joints are not to be inserted beyond "stop-mark" on spigot end.

A resilient connector per ASTM C923 (i.e. water stop) shall be installed on the PVC pipe where it connects into a concrete manhole. After a reach (manhole-to-manhole) of installed PVC pipe has been backfilled to finish grade, it shall be tested

for excessive leakage by a low-pressure air test, conducted in accordance with ASTM F1417.

The testing method selected shall properly consider the existing groundwater elevations during the test. If the test section fails the test for excessive leakage, the contractor shall repair or replace all defective materials and/or workmanship at no additional cost to the Department.

Deflection testing shall be conducted in accordance with Subsection 3.2.3(D).

iv. Ductile Iron Pipe (DIP)

DIP shall be installed in accordance with ANSI/AWWA C105/A21.5 and the latest publications available from the Ductile Iron Pipe Research Association (e.g. Installation Guide for DIP).

The Field Engineer may require field testing of protective linings for DIP. Pipe found with damage or Holidays to the protective lining shall be removed and replaced, or repaired immediately. Repair of damaged areas of the protective lining shall be in accordance with the recommendations of the lining applicator. Repaired areas shall be equal, in all respects, to undamaged lined areas.

An Approved coating material shall be used for field cuts of DIP pipe. A minimum coating thickness of 10 mils shall be applied to the exterior surface of the pipe spigot. The coating material shall be allowed to dry properly before pipe assembly.

Direct-bury installations of DIP shall be encased with polyethylene wrap. Exposed installations of DIP and ductile iron fittings (e.g. above ground, vaults, wet-wells and casings) shall have an applied exterior coating in accordance with the Sewer Plans or as directed by the Field Engineer.

After a reach (manhole-to-manhole) of installed DIP pipe (gravity) has been backfilled to finish grade, it shall be tested for excessive leakage by a low-pressure air test, conducted in accordance with ASTM C924. Gravity sewer reaches with composite pipe materials (e.g. VCP, PVC and DIP) shall be tested in accordance with Subsection 3.2.3(D)(iii).

For DIP force main installations, after all pipe, fittings and appurtenances have been completely installed, they shall be tested for excessive leakage by a hydrostatic pressure test in accordance with ANSI/AWWA C600.

v. High-Density Polyethylene (HDPE) Pipe

Force main installations with HDPE pipe shall be installed in accordance with ASTM D2774, AWWA M55 and the latest installation publications available from the Plastic Pipe Institute (e.g. Handbook of Polyethylene Pipe).

Prior to the site delivery of the pipe, the Contractor shall provide the following information to the Field Engineer:

- Detailed procedures to be used in joining and installing the piping system, including manufacturers' recommendations;
- Interface of piping system to equipment and appurtenances; and
- Bill of materials, indicating material composition of pipe, pressure rating, nominal size with wall dimensions, and its locations on the piping installation drawing.

HDPE pipe and fitting joints shall be heat fused by a qualified technician trained by an approved manufacturers' representative, in accordance with the manufacturer's recommended fusion procedures. Training shall have occurred in the previous 12 months or submittals verifying field installation experience within the previous 12 months for all technicians performing heat fusion on HDPE pipe and fittings shall be submitted prior to the start of installation.

All necessary precautions shall be taken to prevent damage or contamination to the pipe and other incidental materials during shipment and delivery. All materials shall be securely fastened to the truck or rail car to prevent movement or damage during shipment. The Contractor shall examine all materials before unloading.

All pipe materials shall be handled so as to prevent damage. HDPE pipe shall not be dropped, rolled, or pushed off from any height on delivery, storage, or installation.

All pipe materials shall be stored off the ground in a dry location. Pipe shall be stored to prevent sagging or bending. Stored pipe shall be protected from exposure to ultraviolet light.

All piping shall be inspected to assure that it is free from defects in material and workmanship. The compatibility of all pipes and fittings shall be verified.

Pipes, fittings and accessories that are cracked, damaged, unidentifiable, or in poor condition, shall be rejected. Pipe sections or fittings containing significant scratches, dents or marks that are not in accordance with the manufacturer's criteria for such blemishes, may be cause for rejection at the sole discretion of the Field Engineer.

The Field Engineer shall have free access to all joints, including test joints, for determining the suitability of the joining procedure. Where construction restrictions limit inspection of joints, the Field Engineer may direct the individual joining the pipe and/or fittings to perform a test in a manner that it can be clearly and easily observed. The Field Engineer shall select the method of testing from either visual examination, bent strap testing, or ultra-sonic testing. Ultra-sonic testing shall conform to the requirement of the U.S. Department of Transportation as found in the code of federal regulations 49, Part 192.285(b)(ii) or (b)(iii).

HDPE pipes and fittings shall be heat-fused together to create a homogeneous joint. Joining shall be performed in accordance with the manufacturer's heat fusion recommendations. Solvent weld joints are not permitted.

Personnel responsible for heat fusing the joints shall demonstrate proficiency by fusing trial joints and testing the trial joint by bent strap testing or ultra-sonic testing. Trial joints shall be allowed to cool completely before testing and shall not fail at the joint. During construction, the first fusion of the day shall be a trial fusion that shall be allowed to cool and tested either by a destructive bent strap test or with an ultrasonic testing device. If the joint fails, additional trial joints shall be made and tested until successful fusions are completed. The procedure used to join the trial joint shall be used for the balance of the day's work, provided the procedure is in compliance with that recommended by the manufacturer. The Field Engineer shall provide written notice to the Contractor of the unacceptability of any welding technician who is deemed deficient in welding HDPE pipe. In any case, the welding technician shall not be utilized by the Contractor unless the individual undergoes additional training and re-certification for HDPE pipe welding.

HDPE pipe shall be installed to minimize shear and tensile stresses and in accordance with S.D.s RWRD-104 and -500 or as indicated in the Sewer Plans.

After HDPE piping has been backfilled to finish grade, it shall be tested for field leaks by a hydrostatic pressure test in accordance with ASTM F2164 and A.A.C. R18-9-E301(D)(4)(f).

vi. Fiberglass Reinforced Pipe (FRP)

For direct bury installations, trench construction shall conform to Subsection 3.1.3(A). Bedding and shading material for FRP and FRP fittings shall be in accordance with the Sewer Plans and the manufacturer's requirements. Backfill material shall conform to the requirements of Subsections 3.1.2(C) and 3.1.2(D), as applicable. The placement and compaction of shading and backfill material shall conform to Subsections 3.1.3(E) and 3.1.3(F).

For slip lining and tunnel carrier installations, annular space grouting shall not damage the liner and shall conform to the manufacturer's requirements.

FRP shall be handled with textile slings, other suitable materials or a forklift. Use of chains or cables is not permitted.

The jointing of FRP shall be accomplished as described in following:

- (1) Clean ends of pipe and coupling components;
- (2) Apply joint lubricant to pipe ends and elastomeric seals of coupling. Use only lubricants approved by the pipe manufacturer;
- (3) Use suitable equipment and end protection to push or pull the pipes together;
- (4) Do not exceed forces recommended by the manufacturer for coupling pipe; and
- (5) For direct bury installations, join pipes in straight alignment then deflect to required angle. Do not allow the deflection angle to exceed manufacturer's limits.

Manholes for FRP shall be constructed using pipe tee base fittings that are encased in concrete. The encasement shall be designed to prevent distortion of the tee base from heavy loads. This encasement shall also serve as the base to support pre-cast or cast-in-place concrete riser structures per Subsection 3.3.3(B)(i).

Where an FRP end must be connected into a concrete manhole, a resilient connector per ASTM C923, or joint coupling per ASTM D4161, shall be installed on the pipe to provide a watertight connection.

Field testing for direct bury, jacking and tunnel carrier installations of FRP shall conform to the following:

- (1) Each reach may be tested by low-pressure air per Subsection 3.2.3(D)(iii). The system passes the test if the pressure drop caused by leakage through the pipe or pipe joints is less than or equal to the specified amount over the prescribed time period;
- (2) For pipes large enough to enter, individual joints may be pressure tested per Subsection 3.2.3(D)(iv) in lieu of line infiltration, exfiltration or low-pressure air testing; and
- (3) Deflection testing shall conform to Subsection 3.2.3(D)(iv).

Field testing for sliplining installations of FRP shall be based on a CCTV inspection per Subsection 3.2.3(D)(viii). The CCTV inspection shall be performed after grouting to assure that all joints are properly assembled, that no damage exists and that any leakage or deformation is within the allowable limits in accordance with Subsection 2.3.2(D)(iv).

vii. Reinforced Concrete Pipe (RCP)

In addition to any deficiencies not covered by the applicable ASTM specifications, individual concrete pipe sections shall be subject to rejection if any of the following occur:

- Surface defects indicating honeycombed or open texture that would adversely affect the function of pipe sections. Onsite repairs may be made, if Approved by the Field Engineer;

- Damaged ends, that would prevent making a satisfactory joint;
- Pipe that has been excessively patched or repaired. The manufacturer may request that the Field Engineer perform an inspection at the plant, prior to delivery, to assess patching and/or repair work on conduits. Pipe damaged during shipment or construction may be repaired with the Approval by the Field Engineer;
- Exposed reinforcement with the exception of the ends of longitudinals, stirrups, and spacers, that are used to position reinforcing steel, and may be repaired with the Approval by the Field Engineer;
- Concrete pipe delivered to the site greater than 5 calendar days prior to the start of sewer construction unless otherwise Approved by the Field Engineer;
- Broken bells or spigots on installed pipeline; and
- Joint gaps greater than manufacturer's allowable limits.

Acceptance of the pipe at point of delivery will not relieve the Contractor of full responsibility for any defects in materials due to workmanship.

RCP shall be installed in accordance with ASTM C1479 and the latest installation guides and procedures of the American Concrete Pipe Association (e.g. Concrete Pipe Installation Guide).

RCP shall be placed with the grove or bell end upstream. Each conduit section shall be set into position and checked for line and grade prior to continuing placement. The manufacturers' recommendations shall be closely followed during installation.

The Contractor shall ensure that all RCP is kept clean and free from gravel, dirt and debris during and after installation. Precautions shall be taken by the Contractor to eliminate soil and debris from being washed into the sewer prior to completion of sewer construction.

For RCP 30-inches in diameter and greater, if the end-face joint gap is greater than or equal to 65% of the manufacturer's limits, the entire internal joint perimeter shall be grouted with an Approved non-shrink grout product. If the end-face joint gap is greater than the manufacturer's limits at any point around the internal joint perimeter, the adjoining pipe sections will be rejected.

After a reach (manhole-to-manhole) of installed RCP has been backfilled to finish grade, it shall be tested for excessive leakage in accordance with the applicable testing requirements of ASTM C924.

C. Service Lateral (HCS/BCS) Connections

Direct connections of 4-inch service laterals to the Public Sewer line shall be installed in accordance with S.D. RWRD-401 or as Approved per the Sewer Plans. The spacing between a tapping saddle and: another tapping saddle, a pipe joint or a manhole shall conform to the pipe manufacturer's recommendations. No portion of the tapping saddle or service lateral shall protrude into the sewer line.

Where indicated in the Sewer Plan, the connection of 4-inch service laterals into manholes shall conform to S.D. RWRD-402. The connection of 6 inch diameter service laterals and greater into manholes, shall conform to S.D.s RWRD-200 to -203. Drop manhole connections for service laterals shall be avoided, unless Approved by Technical Services and Engineering. Drop manhole connections for service laterals shall be constructed per S.D. RWRD-231.

The horizontal alignment of service laterals (HCS/BCS) shall be perpendicular to the sewer line and without bends, unless otherwise indicated in the Sewer Plans or as Approved by the Field Engineer.

The vertical alignment of service laterals shall conform to pipe manufacturer recommendations, local building codes and S.D. RWRD-401. For new or existing underground utilities or other obstacles that will hinder the vertical alignment of a new service lateral, the service lateral may be rerouted per S.D. RWRD-400.

For existing service laterals encountered during non-sewer related construction, the service laterals shall be protected, repaired or rerouted per S.D. RWRD-400, as the situation dictates and at no expense to the Department or the property owner.

Backfill material for service laterals, located within Right-of-Way and Public Sewer easements, shall be compacted in accordance with Subsection 3.1.3(F).

Cleanout risers shall be constructed for 4-inch service laterals per S.D. RWRD-404. For buried cleanout risers (i.e. Type III), the Contractor shall be responsible for completing and submitting a *Memorandum of Understanding for Type III Buried Cleanout Risers* form to the Field Engineer, prior to Construction Acceptance. The completed form must be signed and dated by the owner/developer of the Project and a representative from the home builder. Contact the Field Engineer for the latest version of this form.

Temporary caps shall be furnished and installed at the end of new service laterals. Installed caps shall be capable of withstanding earth loads and low-pressure air testing.

An Approved marking tape for service laterals shall be installed in accordance with S.D. RWRD-401. The marking tape shall have continuous printing stating, "CAUTION: PRIVATE HCS/BCS", unless otherwise Approved by the Field Engineer.

The method of disconnection and abandonment for existing service lateral connections will be determined on a case-by-case basis by the Field Engineer.

Any damage to existing Public Sewers as the result of a new service lateral connection shall be reported immediately to the PCRWRD Operations Control Center (OCC) at (520) 724-6500.. Any costs incurred by the Department for repairing damage to Public Sewers will be billed to the Applicant of the new sewer connection. The Agency having jurisdiction over the building codes will be asked

not to release permits or certificates of occupancy until the Department has received payment.

D. Sewer Line Testing and Tolerances

The construction of new Public Sewer lines shall be inspected and tested in accordance with the applicable methods specified in AAC R18-9-E301(D) and as required by the Department.

i. General

During the construction of Public Sewers, the Contractor shall provide access to the trench and installed pipe to allow for inspections by the Field Engineer.

ii. Mirror Inspections

Mirror inspections shall be used for identifying alignment deficiencies in a sewer line during the progress of construction and prior to the final CCTV inspection. Each sewer line reach (manhole-to-manhole) shall be visually inspected by directing a beacon of light into the pipe from a light source such as a flashlight or reflecting sunlight with the use of mirrors. If the illuminated interior or “moon” of the pipe indicates deficiencies in alignment such as bellies, sags, reverse slopes or offset joints, the Contractor shall correct the alignment deficiency prior to the final CCTV inspection.

iii. Low-Pressure Air Testing

After new sewer lines and service laterals (HCS/BCS) are constructed and backfilled to finish grade, each reach shall be tested for no excessive leakage by low-pressure air testing. The requirements for low-pressure air testing shall be in accordance with the applicable methods specified in AAC R18-9-E301(D) and the installed pipe material’s air testing requirements. Sewer lines and service laterals found with excessive leakage shall be corrected by the Contractor and re-tested as necessary until the results are passing. Testing results and any required corrections shall be documented by the Contractor and provided to the Field Engineer.

Low-pressure air testing for a reaches sewer line with composite pipe materials (i.e. PVC with DIP sections) shall be in accordance with the predominant pipe material within that reach.

iv. Joint Testing

For sewer lines greater than 48 inches in diameter, low-pressure air testing may be superseded by testing each pipe joint for no excessive leakage in accordance with ASTM C1103 (RCP) and the applicable pipe manufacturer recommendations. Pipe joints found with excessive leakage shall be corrected by the Contractor and re-tested as necessary until the testing are passing. Testing results and any required corrections shall be documented by the Contractor and provided to the Field Engineer.

Specific guidelines for joint testing procedures are provided in the following:

(1) Joint Testing Equipment

The Contractor shall provide all materials, labor and equipment necessary for joint testing.

The joint tester frame assembly shall be constructed of a heavy gauge metal that can be broken down easily into small sections for ease of handling and installation/removal from sewer manholes.

The joint tester shall have either single or double-bladder construction. The single bladder shall be of a one-piece construction within an outer layer of a soft, natural rubber, between the pipe and tester.

The double-bladder tester shall have 2 inflatable bladders constructed of rugged heavy-duty elastomer. The bladders shall be stretched and positioned onto the joint tester frame assembly so that they can be aligned over the joint to be tested. When inflated, the bladders shall create an air-tight seal against the pipe wall.

The control panel for the joint test shall provide a reliable means of controlling and monitoring bladder and center cavity pressures. The control panel shall be conveniently mounted onto the joint tester frame assembly and require only input air from the compressor.

Wheel assemblies shall be mounted to the inside surface of the joint tester frame. The Contractor shall be capable of efficiently moving and centering the joint tester to each pipe joint.

An air reservoir shall be included in the joint test system and shall have a maximum volume of 2.5 cubic feet. Hoses shall be provided to route air from the control panel to the air reservoir and from the air reservoir to the center cavity chamber.

(2) Joint Testing Procedure

The test pressure shall be 3.5 psi unless otherwise specified by the pipe manufacturer.

Position the joint tester so the bladder(s) are properly located over the joint to be tested. Inflate the bladder(s) to 50 psi or in accordance with testing equipment and manufacturer's instructions.

Begin pressurizing the center cavity chamber. When the testing pressure is reached, turn off the pressure source and allow the pressure to stabilize for approximately 10 to 15 seconds.

If the pressure drops less than or equal to 1 psi for a period of 5 seconds, the pipe joint is acceptable. If the pressure drops more than 1 psi for a period of 5 seconds, the joint is defective and shall be repaired and retested.

When the joint test is completed, all pressure must be exhausted from center cavity to 0 psi and then from the bladder(s) to 0 psi. The joint tester can then be transported and positioned on the next joint to be tested.

(3) Sealing of Failed Joints

If Approved by the Field Engineer, the Contractor may seal a joint to ensure that it is watertight instead of a joint test. The sealing method shall consist of the following steps:

- Prime the sides of the concrete joint according to the primer manufacturer's instructions;
- Install a backer rod of a certain size, in the bottom of the joint, so as to leave a 1/2- to 5/8-inch depth for the flexible sealant; and
- Install a non-sagging, two-component elastomeric sealant in accordance with the sealant manufacturer's instructions.

v. Hydrostatic Pressure Testing

After a new force main is backfilled to finish grade, it shall be tested for no excessive leakage by hydrostatic pressure testing. Water from a potable water source shall be used for this testing procedure. The requirements for hydrostatic pressure testing shall be in accordance with the applicable methods specified in AAC R18-9-E301(D)(4)(f) and the installed pipe material's testing requirements. If the results of the testing indicate excessive leakage in the force main, it shall be corrected by the Contractor and re-tested as necessary until the results are passing. Testing results and any required corrections shall be documented by the Contractor and provided to the Field Engineer.

The Contractor shall verify that all inline valves and air relief valves, located along the test section of the force main, are completely open during filling and testing of the force main with water. After the force main is filled with water, it shall stand under a slight pressure (3-psi) for at least 48 hours prior to performing the hydrostatic pressure test. This retention period is necessary to allow for the release of entrained air and entrapped air bubbles. During this retention period, bulkheads, valves, and other accessible pipe connections shall be examined for leaks and repaired by the Contractor, prior to hydrostatic pressure testing.

vi. Mandrel Deflection Testing

New sewer lines having flexible pipe materials (e.g. PVC, HDPE, FRP), shall be tested for uniformity in shape, by a mandrel deflection test. The mandrel deflection test shall occur at least 7 days after backfill compaction has been completed and prior to Construction Acceptance of the Project. Deflection testing shall be conducted using a deflection testing mandrel (go/no-go mandrel) per S.D. RWRD-107. Mandrels shall be pulled completely through each reach by hand (1 person) and without requiring the use of excessive force (e.g. use of tools, leverage or machinery). If a mandrel becomes caught or bound, the reach shall fail the test. Failed reaches shall be corrected by the Contractor and re-tested as necessary until passing.

For sewer lines greater than 48 inches in diameter, other methods of deflection testing such as direct measurements using extension rulers or the successful completion of joint testing, may be Approved by the Field Engineer.

vii. Slope Tolerances

The Contractor shall make every effort possible to ensure that the constructed slopes of sewer lines conform to the Sewer Plans. If a slope error is found in the Sewer Plans or if the constructed slope of a sewer line does not conform to the Sewer Plans, the Contractor shall notify the Field Engineer immediately. Table 3.1 is provided as a guideline for determining the allowable slope tolerances for 8-inch diameter sewer lines. For larger diameter sewer lines, the allowable slope tolerances will be determined by the Department. In no case, shall slope tolerances allow for constructed slopes to be less than the minimum slopes required per AAC R18-9-E301(D)(2)(e).

For constructed slopes of sewer lines that are not within the slope tolerances specified by the Department, the Contractor may request a Variance in accordance with the *Design Standards*, Subsection 2.3. The Department will review the request and elect one of the following options:

- Approve the Variance request;
- Require the As-Built Plans to be certified by the Design Engineer with a statement indicating that the constructed sewer meets the intent of the design and conforms to R18-9-E301 – 4.01 General Permit; or
- Require unacceptable sewer construction to be removed and reconstructed in accordance with the Sewer Plans.

Table 3.1
Allowable Slope Tolerances for
8-inch Diameter Sewer Lines (ft/100ft)

Slope per Sewer Plan	Tolerable Range	
	Lower Limit	Upper Limit
0.33*	0.33*	0.39
0.34	0.33*	0.40
0.35	0.33*	0.41
0.36	0.33*	0.42
0.37	0.33*	0.43
0.38	0.33*	0.44
0.39	0.33*	0.45
0.40	0.34	0.46
0.41	0.35	0.47
0.42	0.36	0.48
0.43	0.37	0.49
0.44	0.38	0.50
0.45	0.39	0.51
0.46	0.40	0.52
0.47	0.41	0.53
0.48	0.42	0.54
0.49	0.43	0.55
0.50	0.44	0.56
0.51	0.45	0.57
0.52	0.46	0.58
0.53	0.47	0.59
0.54	0.48	0.60
0.55	0.49	0.61
0.56	0.50	0.62
0.57	0.51	0.63
0.58	0.52	0.64
0.59	0.53	0.65
0.60	0.54	0.66
0.61	0.55	0.67
0.62	0.56	0.68
0.63	0.57	0.69
0.64	0.58	0.70
0.65	0.59	0.71
0.66	0.60	0.72
0.67	0.61	0.73
0.68	0.62	0.74
0.69	0.63	0.75
0.70	0.64	0.76
0.71	0.65	0.77
0.72	0.65	0.79
0.73	0.66	0.80
0.74	0.67	0.81
0.75	0.68	0.83
0.76	0.68	0.84
0.77	0.69	0.85
*Minimum slope per AAC R18-9-E301(D)(2)(e)		

viii. CCTV Inspection

Each reach of newly constructed sewers shall be inspected by CCTV after it has passed all other required testing per Subsection 3.2.3(D). The CCTV inspection shall occur at least 7 Days after the compaction of backfill is completed. The CCTV inspection shall serve as a final verification that alignment deficiencies do not exist within the newly constructed sewers. Alignment deficiencies may, include, but are not limited to; bellies, sags, reverse slopes and offset joints. If alignment deficiencies are found during the CCTV inspection, it shall be corrected by the Contractor and the reach re-tested and inspected as necessary until the results are passing.

The Department will be responsible for providing one CCTV inspection service for each reach. The Contractor shall be responsible for subsequent CCTV inspections of any reach. Subsequent CCTV inspections may occur after the Bill of Sale is issued and during the Contractor's warranty period. The Contractor shall be responsible for providing required corrective actions as a result of alignment deficiencies that may be found.

On the day before the scheduled CCTV inspection, the Contractor shall perform a "water dump" for the reaches to be inspected. The "water dump" shall supply water, from a potable source, to the upstream manholes of the new sewer lines so that water runs completely through. The downstream manhole(s) of these reaches shall be dewatered prior to the CCTV inspection.

The Contractor shall provide sufficient vehicular access to the reach manholes. The Contractor shall ensure that the reaches to be inspected and associated manholes are free of dirt and debris. If dirt or debris is found in a reach, the CCTV inspection for that reach will be abandoned and rescheduled for another day. A remobilization fee will be charged to the Contractor for rescheduled inspections due to dirt or debris within a reach.

If any standing water is found within a reach, the maximum depth and length of the sag will be measured with CCTV equipment. Table 3.2 provides guidelines for determining if corrective actions are required by the Contractor for found sags.

The Contractor shall bear all costs incurred for required corrective actions and subsequent CCTV inspections of repaired reaches. The corrective actions by the Contractor shall minimize the use of repair couplings, as directed by the Field Engineer. Required corrective actions as a result of pipe material defects or other construction defects will be determined the Field Engineer on a case-by-case basis.

Table 3.2
Allowable Tolerances for Sags Found within a Reach

Reach Dia. [inches]	Sag Depth [inches]	Sag Length [feet]	Corrective Action Required
8 to 12	Less than or equal to $\frac{5}{8}$ inch	N/A	No
8 to 12	Greater than $\frac{5}{8}$, but less than or equal to $1\frac{1}{4}$ inches	Greater than 10 or more than 3 occurrences within 100 feet	Yes
8 to 12	Greater than $1\frac{1}{4}$ inches	N/A	Yes
14 to 24	Less than or equal to $1\frac{1}{4}$ inches	N/A	No
14 to 24	Greater than $1\frac{1}{4}$, but less than or equal to 2 inches	Greater than 20 or more than 3 occurrences within 100 feet	Yes
14 to 24	Greater than 2 inches	N/A	Yes
<p>Notes:</p> <p>(a) Corrective actions required will be determined by the Field Engineering section for reach diameters greater than 24 inches having sags greater than 5% of the diameter.</p> <p>(b) Pondered water as a result of manhole construction shall require corrective action.</p> <p>(c) For multiple sags, corrective actions shall occur in the order of severity (highest first).</p>			

For CCTV inspections services provided by the Department, the Field Engineer shall be responsible for:

- Scheduling CCTV inspections with the Contractor;
- Monitoring “water dumps”;
- Monitoring CCTV inspections;
- Within 1 Day of the CCTV inspection, providing the Contractor with a copy of the CCTV inspection reports and photos of any alignment deficiencies; and
- Within 1 Day of the CCTV inspection, providing the Contractor with a written report disclosing all required corrective actions.

The Contractor shall provide written notice to the Field Engineer, at least 3 weeks in advance, to schedule CCTV inspections.

If possible, the Department will accommodate CCTV inspection scheduling for special circumstances. Such requests shall be arranged with the Field Engineer during the pre-construction meeting. If a CCTV inspection is scheduled less than 3 weeks of the pre-construction meeting, the Department will commit to an inspection date at the pre-construction meeting.

The Contractor shall re-confirm the scheduled CCTV inspection with the Field Engineer a minimum of 2 Working Days in advance. The Field Engineer will also notify the Contractor of any scheduling delays, a minimum of 2 Working Days in advance. If the Contractor cancels a scheduled CCTV inspection less than 2 Working Days in advance, a re-mobilization fee will be charged to the Contractor. CCTV inspections may be phased if Approved by the Field Engineer, however, a mobilization fee will be charged for additional trips.

If the Department cannot commit to a requested date for CCTV inspection, the Contractor may obtain CCTV inspection services by a qualified subcontractor, in accordance with the following guidelines:

- At the time of scheduling, the Contractor shall obtain Approval from the Field Engineer for CCTV inspection services by a subcontractor;
- CCTV inspection by a subcontractor shall be conducted under the observation of the Field Engineer;
- CCTV inspections by a subcontractor shall be conducted in accordance with NASSCO guidelines;
- CCTV inspection reports and a continuous video of each reach (DVD format) shall be provided to the Field Engineer;
- CCTV equipment and software shall be expressly designed for pipeline inspection purposes and operated by NASSCO-certified personnel;
- Subsequent CCTV inspections by a subcontractor shall use the same data management processes as the prior CCTV inspection;
- CCTV equipment and software shall be Approved by the Field Engineer prior to use;
- The CCTV camera shall have a mechanical gauge to record the depth of any standing water; and
- The mechanical gauge shall clearly indicate markings of $\frac{5}{8}$ -inches and $1\frac{1}{4}$ -inches for reaches having a nominal diameter of 8-inches to 12-inches, and markings of $1\frac{1}{4}$ - and 2-inches for reaches having a nominal diameter of 15 inches to 24 inches.

If the CCTV inspection services by a subcontractor strictly adhere to the Departments standards, it shall serve as the final CCTV inspection. Non-conforming or incomplete CCTV inspections for any reach may require a subsequent CCTV inspection by the Department, prior to Construction Acceptance.

E. Markers

Force mains shall be installed with a tracer wire and metallic marking tape in accordance with S.D. RWRD-500 and -501. Test stations per S.D. RWRD-501 shall be located as indicated per the Sewer Plans. Test Stations per S.D. RWRD-501 shall be installed with approved electronic balls and located as indicated per the Sewer Plans.

Abandonment markers per S.D. RWRD-503 shall be located in accordance with the Sewer Plans or as Approved by the Field Engineer.

F. Modifications and Repairs

Modifications and repairs to existing sewer lines shall conform to S.D.s RWRD-102 and RWRD-103. All sewer modifications and repairs shall be inspected by the Field Engineer prior to being backfilled. Placement and compaction of bedding, shading and backfill material shall conform to the applicable requirements of Subsection 3.1.3.

The Contractor shall replace "in kind" any existing survey monuments damaged or disturbed during construction (including property pins). This replacement shall be performed by an Arizona Registered Land Surveyor and shall also require a record of survey.

G. Abandonment of Pipe

Existing Public Sewer lines that are to be abandoned shall be removed completely. Where indicated in the Sewer Plans or Approved by the Field Engineer, existing Public Sewer lines that are to be abandoned-in-place shall be filled with grout or pipe burst. Existing Public Sewer lines that are abandoned-in-place except for burst pipes shall be marked with an abandonment marker per S.D. RWRD-503.

The removal of asbestos cement pipe material and other asbestos containing material shall conform to the requirements of Section 940 of the *PAG Standard Specifications*.

Debris that is generated by the removal of existing Public Sewer lines shall be removed from the site by the Contractor and disposed of at an appropriate solid waste facility. The Contractor shall furnish the Field Engineer the original copy of the dumping receipt. Disturbed areas shall be backfilled with backfill material per S.D. RWRD-104 and compacted to a minimum density of 95% of the standard proctor density in accordance with the provisions of the Arizona Test Method 225 and the compaction standards set forth by the Agency controlling the Right-of-Way.

3.3 Sanitary Sewer Manholes

3.3.1 Description

The work under this subsection consists of furnishing all materials required to construct, modify or adjust sanitary sewer manholes as indicated in the Sewer Plans and the *Standard Specifications and Details*.

3.3.2 Materials

A. Concrete

Portland cement shall conform to the requirements of ASTM C150. Type II Portland cement shall be used for concrete unless otherwise specified in the Sewer Plans or the Special Provisions. All other materials furnished for Portland cement concrete shall conform to the requirements of Section 1006 of the *PAG Standard Specifications*. Concrete design mixture shall be class "S" and have a minimum 28-day compressive strength of 3,000 psi, unless otherwise specified in the Sewer Plans or Special Provisions.

B. Reinforcing Steel

Materials furnished for reinforcing steel shall conform to the requirements of Section 1003 of the *PAG Standard Specifications*.

C. Grout and Mortar

Portland cement shall conform to the requirements of ASTM C150. Type II Portland cement shall be used for grout and mortar, unless otherwise specified in the Sewer Plans or Special Provisions. All other materials furnished for grout and mortar shall conform to the requirements of Section 914-2.03 of the *PAG Standard Specifications*.

Approved non-shrink grout products shall conform to the requirements of Section 1017-4 of the *PAG Standard Specifications*. Refer to the Department's List of Approved Products for the recommended non-shrink grout products.

D. Water

Water shall conform to the requirements of Subsection 1006 of the *PAG Standard Specifications*.

E. Precast Concrete Manhole Sections

Precast concrete manhole sections shall be free from cracks, voids and other defects and shall conform to the requirements of ASTM C478 and AASHTO M199. Precast concrete manhole sections shall include:

- Bases
- Risers
- Cone and Flat Top Transitions
- Cones
- Flat Top Slabs
- Grade Adjustment Rings; and
- Joint Adapters.

F. Interior Corrosion Protection

Refer to the Department's List of Approved Products for the recommended products for the interior corrosion protection of manholes.

G. Steps

Steps for precast and cast-in-place manholes shall be approved and conform to the requirements of ASTM C478, D4101 and A615. Steps shall be reinforced with ½-inch diameter, grade 60 steel and coated with polypropylene plastic. Refer to the Department's List of Approved Products for the recommended manhole steps.

H. Frames, Covers and Hatches

Frames and covers for Public Sewer manholes shall conform to S.D.s RWRD-213 to -218, unless otherwise Approved by the Field Engineer. In these cases, a certificate of compliance with Subsection 3.3.2(H) shall be provided from the manufacturer upon request.

All castings shall be true to pattern, in form and dimension, and free from pouring faults, sponginess, cracks, blowholes, or other defects in locations affecting their strength for the service intended. Castings shall be filleted boldly at angles and the risers shall be sharp and true. Before the castings are removed from the foundry, they shall be thoroughly cleaned and the parting lines, gates and risers shall be ground flush. No plugging or other stopping of holes shall be allowed. The castings shall be thoroughly cleaned of all lumps and shall be subject to a careful hammer test.

Lettering for covers shall be standard raised block type, and shall be 1¼ to 2½ inches high. The total width of individual letters are to be such that letters and words are equally spaced and balanced to form a complete circle with spaces before and after words.

The top surface of the cover shall sit flush with the top surface of the frame. A uniform ⅛ inch clearance shall exist between the edge of the cover and the frame. All horizontal bearing surfaces shall be machine finished.

The weight of the frame and cover shall be no more than 2% less than the approximate weight specified in the applicable standard detail for each component.

Frames and covers shall be manufactured from gray iron, conforming to the requirements of ASTM A48, Class 35B. Frames and covers shall be designed for H-20 loading inclusive of the proof load requirements outlined in Section 7 of the American Association of State Highway and Transportation Officials (AASHTO) Standard Specification for Drainage Structure Castings, ASSHTO Designation M 306.

Frames and covers shall be made from ferrous materials using at least 75% post-consumer waste. The basic design, initial sample castings and first article

inspection (also known as first proof load tests) must be Approved by the Field Engineering manager before delivery to suppliers or Contractors.

The bearing surfaces of the frames and covers shall be machine finished so that the covers will seat themselves firmly onto the frame. Vehicular traffic shall not cause the frame to move. A 1/8inch annular clearance shall be provided between frame and cover.

The design and construction of private sewers may utilize, or make reference to certain Department specifications and details; however, the covers for private manholes shall not be imprinted with the words "Pima County Sanitary Sewer". Manholes to be owned and operated by a private entity shall be unlabeled or have the following words cast into them "Private Sanitary Sewer", or other appropriate designation.

I. Flexible Joint Gaskets

Preformed flexible plastic gaskets for the sealing the joints of precast concrete manhole sections shall be Approved and conform to ASTM C990 or AASHTO M198B. Refer to the Department's List of Approved Products for the recommended flexible joint gaskets.

3.3.3 Construction Details

A. Excavation and Backfill

Excavation for new manhole construction shall be in accordance with Subsection 3.1.3(A) and Section 203 of the *PAG Standard Specifications*. The foundation for new manhole bases shall conform to Subsection 3.1.3(B) or as Approved by the Field Engineer.

The Department assumes no liability for damage to, or removal of, any vegetation, above ground or below ground facilities, surface treatments, materials, equipment, or structures placed within Public Sewer easement or within 20 vertical feet of its surface.

Backfill material for new manholes shall conform to Subsection 3.1.3(E) and S.D. RWRD-104.

B. Installation of Manholes

i. **Manhole Bases**

For 48-inch and 60-inch diameter manholes, the base and the flow channel configuration shall be constructed in accordance with S.D.s RWRD-200, -201 and -202, unless otherwise indicated in the Sewer Plans or as Approved by the Field Engineer. For larger diameter manholes, the base and flow channel configuration shall be constructed as indicated in the Sewer Plans.

In no case shall any pipe within the manhole discharge onto the surface of the bench.

Flow channels shall be constructed to conform in size and shape to that of the interior surface of the connected pipes. Flow channels shall be free of sags and sloped to convey flow from the influent pipes to the outgoing pipes. Flow channels shall not obstruct flow or cause water to pond within the influent pipes.

If additional concrete or mortar is needed after the initial set, the receiving surface shall be primed and mixed with an Approved adhesive in order to secure a surface that is as chip-proof as possible. The base shall be set a minimum of 72 hours before the manhole construction is initiated.

For a new manhole constructed over an existing sewer line, a saw cutter shall be used to remove the top portion of the pipe. This cut-out shall take place under the inspection of the Field Engineer. The Contractor shall be careful to prevent cuttings from falling into the pipe. If this occurs, the Field Engineer may require the Contractor to clean the sewer line. After a cut-out, the edges of the pipe shall be filled and smoothed with mortar.

ii. Block-Outs

Where designated in the Sewer Plans as a provision for the connection of a future sewer line, a block-out shall be built into the manhole per S.D. RWRD-203.

iii. Precast Concrete Manhole Sections

Precast manhole sections shall be installed in accordance with S.D.s RWRD-205 and -206 and the manufacturer's recommendations.

Precast sections will be inspected by the Field Engineer at the job site and may be rejected if any of the following deficiencies exist:

- Fractures or cracks passing through the wall, except for a single end crack that does not exceed the depth of the joint;
- Defects that indicate imperfect proportioning, mixing, and molding;
- Surface defects indicating honeycombed or open texture;
- Damaged or cracked ends, where such damage would prevent making a satisfactory joint; or
- Any continuous crack having a surface width of 0.01 inches or greater and extending for a length of 12 inches or greater, regardless of position in the section wall.

Proper equipment shall be provided for lowering the precast sections into position. The tongue end of the section shall be placed in contact with the base structure, unless otherwise Approved by the Field Engineer. Not more than two lifting holes shall be cast or drilled in the wall of each section. All lifting holes shall be filled with an Approved sealing compound on the exterior side of the wall and a minimum of ½-inch deep on the interior side of the wall. Any precast section damaged during

transportation or placement shall be repaired or replaced at the option of the Field Engineer and at the Contractor's expense.

All precast manhole section joints shall be sealed with a preformed flexible plastic gasket in accordance with Subsection 3.3.2(I). The gasket shall be installed in accordance with the following requirements:

- The sealing compound shall be packaged in an extruded pre-formed rope-like shape of proper size to completely fill the joint when fully compressed;
- The material shall be protected by a suitable, removable wrapper;
- The joint surfaces shall be clean and free of mud, silt, gravel or other foreign material prior to the installation of the sealing compound; and
- Installation shall be accomplished in accordance with the manufacturer's instructions as to the method of application, quantity of material, quality of material, and the application temperatures.

For manholes located in ground water conditions, the exterior surface of precast sections and joints shall be coated with an Approved waterproofing sealant.

iv. Steps

Steps for precast manholes shall be installed during the manufacture of precast sections and configured per S.D. RWRD-210. Steps within each manhole shall be of the same product and size. Loose steps shall cause rejection of the precast manhole section.

Steps for cast-in-place manholes shall be installed in accordance with the step manufacturer's installation requirements. Holes for step installation shall be properly sized and formed prior to casting, or the holes shall be drilled into the walls after the concrete has fully cured. The use of grout to secure loose steps shall be prohibited.

v. Cast-in-Place Manholes

When specified in the Sewer Plans, manholes with diameters greater than 60-inches may be cast-in-place. Class "S" concrete, having a minimum compressive strength after 28 Days of 3,000 psi, shall be required for manhole bases. Class "S" concrete, having a minimum compressive strength after 28 Days of 4,000 psi, shall be required for manhole walls. Class "B" concrete may be used for all other portions of the manhole not subjected to corrosive gases. Portland cement shall conform to the requirements of ASTM C150 for Type II cement, unless stated otherwise in the Sewer Plans.

Cast-in-place concrete manholes shall be placed in accordance with the requirements of Section 601 of the *PAG Standard Specifications* and ACI-318. The location of the manhole shall conform to the requirements of the Sewer Plans, unless otherwise Approved by the Field Engineer and before the placement of concrete.

All absorptive surfaces that may come in contact with the concrete, shall be moistened sufficiently to minimize moisture loss from the freshly-poured concrete.

The trench or excavated area must be free of water, dirt, mud and debris before the concrete is poured.

Floor slabs with walls shall be washed free of sawdust, chips, and other debris, after wall forms are built and immediately before the concrete pour. Should the form work confine sawdust, chips and other loose matter in such a manner that it is impossible to remove by flushing with water, a vacuum cleaner shall be used for removal. Following this action, the cleaned surfaces shall be flushed with water.

Before pouring concrete, the forms shall be coated with a non-staining lubricant to prevent adherence of concrete. All forms and form lumber, once used, shall be thoroughly cleaned and contact surfaces re-coated before being used again. Dirty forms shall not be used. Forms may be either metal or wood, and shall be built true to shape, line and grade. Forms shall be mortar-tight and sufficiently rigid to prevent displacement or sagging between supports. Deformed, broken or defective forms shall not be used and shall be removed from the job site.

Contact surfaces for exposed concrete shall be made from plywood, metal or non-warping fiberboard. The pieces used shall be as large as the form layout permits. Small pieces shall not be patched together.

Square-edge lumber may be used as forms for concrete surfaces that will be buried or not exposed to view after construction is completed.

All form work shall have adequate cleanout openings to permit inspection and easy cleaning after all reinforcement has been placed.

When the forms are removed, no metal form ties shall remain within $\frac{3}{4}$ -inch of the surface of the concrete or any holes larger than $\frac{7}{8}$ -inch diameter in the surface of the concrete. Ties made from wire shall not be permitted.

All external angles of beams, columns, edges of concrete structures and sides of walls shall have a $\frac{3}{4}$ -inch chamfer unless otherwise indicated in the Sewer Plans.

vi. Grade Adjustment Rings

Adjustments for existing manholes shall conform to S.D.s RWRD-304 and -305. For manholes in paved areas, a minimum of one precast concrete grade adjustment ring, with a minimum height of 3 inches, shall be provided to allow for flexibility in future elevation adjustments. The maximum height of grade adjustment rings shall not be greater than 15 inches. The inside diameter of the grade adjustment ring(s) shall be equal to the inside diameter of the manhole frame.

vii. Frames, Covers and Hatches

Frames and covers for new manholes shall be installed and adjusted in accordance with S.D. RWRD-205, -206 and -207, as applicable. Frame elevations

shall be as indicated in the Sewer Plans unless otherwise Approved by the Field Engineer. Where the frame is located in pavement or a traveled way, its surface shall be flush with the finish grade. A protective concrete collar shall be constructed in accordance with S.D. RWRD-211 if required by the Agency having jurisdiction over the Right-of-Way or if indicated in the Sewer Plans. Where the frame is located outside of pavement or a travelled way, a protective concrete collar shall be constructed in accordance with S.D. RWRD-212, unless otherwise Approved by the Field Engineer.

The Contractor shall thoroughly scrape and clean all foreign materials from the manhole frames and covers prior to their installation. All frames and covers shall be free of grease, oils, asphaltic materials, and any other deleterious materials. All vent holes, pick bars and bolt holes shall be free of dirt, rocks, concrete and other obstructions prior to Construction Acceptance.

Hatch assemblies for larger manholes and vaults shall be cast into the top of the slab, unless otherwise Approved by the Field Engineer.

viii. Corrosion Protection for New Manholes

Manholes constructed of polymer concrete shall be used for corrosion protection. See RWRD's "List of Approved Products for Sanitary Conveyance Facilities".

A new manhole constructed over an existing sewer line with a diameter of 18 inches or greater shall be corrosion protected.

ix. Reinforced Joints

When specified in the Sewer Plans or as directed by the Field Engineer, precast manhole sections shall be installed with reinforced joints per S.S.D. RWRD-209.

C. Manhole Installation Testing and Tolerances

For pipe deflection angles from 0 to 9 degrees, the flow channel shall not be flat and shall drain into the downstream pipe. For pipe deflection angles from 10 to 45 degrees, the pipe invert elevation tolerance may be plus or minus 0.05 feet. For pipe deflection angles from 46 to 90 degrees, the pipe invert elevation tolerance may be plus or minus 0.10 feet.

In any case where there is a deviation in the constructed pipe invert, the following criteria shall be met:

- Pipe slope tolerances per Subsection 3.2.3(D) are followed;
- Flow is conveyed through the flow channel to the downstream pipe; and
- There is no standing water in the flow channel or in the upstream connected pipes.

The Field Engineer may require testing to verify that the manhole is watertight. Testing shall be conducted after the trench around the manhole has been

backfilled. The negative air pressure test, as specified in ASTM C1244, or a water test, as specified in AAC R18-9-E301, shall be used to test all manholes.

Repairs shall be provided whenever leakage exceeds the test limit.

D. Modification of Existing Manholes

Prior to commencing work on any existing Public Sewer manhole, a sewer Construction Permit shall be secured from the Department. The Contractor shall be responsible for payment of all applicable fees associated with the Construction Permit. See Subsection 1.4.1 for more information. Each manhole shall be thoroughly cleaned and kept clean throughout the duration of sewer construction.

The Contractor shall observe all traffic requirements set forth by the Agency having jurisdiction over the Right-of-Way. Streets shall be kept open for passage of traffic. Protection for the public shall be provided when the manhole excavation occurs. The manhole construction work shall be completely and adequately covered when no work is being done. Flow management of wastewater from Public Sewers shall be accomplished by pumping to a nearby existing manhole or to a tank truck for proper disposal.

i. **Reset Frame and Cover**

Grade adjustments for existing manholes shall conform to S.D.s RWRD-304 and -305. Where an existing manhole will be adjusted for roadway improvements, the Design Engineer and Contractor shall contact the Department's Utility Coordination (UC) group or Field Engineer as early as possible to arrange for an inspection and identify any additional requirements including but not limited to manhole reconstruction per S.D. RWRD-309.

Prior to any adjustment, the bench and flow channels shall be protected with a cover in accordance with S.D. RWRD-306. The cover shall be removed only after all modification work is completed or as Approved by the Field Engineer.

If an existing frame and cover will be temporarily removed for pavement construction, a steel plate of a size and thickness, Approved by the Field Engineer, shall be placed over the manhole opening. After paving is completed, the steel plate shall be removed by cutting and removing the material above it. Care shall be taken so that materials are not disturbed beyond the edges of the plate and that debris is kept from falling into the manhole. The frame shall be protected with concrete collar constructed in accordance with S.D. RWRD-211 or as required by the Agency having jurisdiction over the Right-of-Way.

The Contractor shall thoroughly scrape and clean all foreign materials from the manhole frames and covers prior to their installation. All frames and covers shall be free of grease, oils, asphaltic materials, and any other deleterious materials. All vent holes, pick bars and bolt holes shall be free of dirt, rocks, concrete and other obstructions prior to completion of the Project.

Frames or covers that are damaged by other than the Contractor or that cannot be cleaned to the satisfaction of the Field Engineer shall be replaced at no cost to the Department. Existing frames and covers shall be kept in matching order and stockpiled in an orderly fashion as not to cause damage. Extra frames and covers shall be turned into Department's Conveyance Division at the completion of the project.

ii. Damaged Frames and Covers

Existing manhole frames and covers shall be replaced if the age, condition or type of the existing frame and cover warrants such action. Replacement shall be directed by the Field Engineer. Existing manhole frames and covers, which are lost or damaged by the Contractor, shall be replaced at no additional cost to the Department.

iii. Coring

The following procedures shall be followed when connecting a new sewer line into an existing Public Sewer manhole:

- Core through the concrete at the bench level or in the barrel section to accommodate new pipe;
- After the new sewer line is laid, the opening through the wall around the new pipe shall be sealed with material compatible with existing manhole wall components;
- The new bench and channel shall be formed WITH mortar of Class "S" concrete, using an epoxy additive to assure adequate bonding to the existing bench; and
- All surfaces shall be steel-troweled to create smooth, dense surfaces.

iv. Brick Manholes

Grade adjustments for existing brick manholes shall conform to S.D. RWRD-304.

Prior to reconstruction, the Field Engineer will inspect the existing brick walls to assess its condition. The cone section shall be removed to an elevation within the barrel section where the brick and mortar is not deteriorated and as designated by the Field Engineer. Precast concrete manhole sections shall be used to reconstruct the manhole. Prior to installing the precast sections, a concrete leveling course with a formed joint, per S.D. RWRD-208, is required. Reconstruction of any Public Sewer manhole shall be Approved by the Field Engineer.

v. Connections to Existing Sewers

Where connections to existing manholes are required, the Contractor shall reconstruct the existing bench. All flow channels within new manholes shall be shaped and formed to provide a smooth transition of flow between inlet pipe(s) and outlet pipe(s).

When a new manhole is constructed over an existing sewer line, verification of the horizontal and vertical location is required by the Contractor before the manhole is built. When the horizontal or vertical location of the sewer line does not match the Sewer Plans, the Contractor shall notify the Field Engineer. The Field Engineer may require the Sewer Plans to be updated by the Design Engineer in order to proceed with construction of the manhole.

vi. Corrosion Protection for Existing Manholes

When an interior corrosion protection is required for an existing manhole, its interior shall be cleaned and prepared, prior to applying a coating. During the cleaning and preparation, reasonable means and methods shall be used to prevent foreign matter from entering existing sewer line. A cover per S.D. RWRD-306, modified with a fine-mesh drain screen, may be allowed with Approval by the Field Engineer.

The interior surfaces of the manhole, including the walls, benches and flow channels, shall receive a wet abrasive blasting using a minimum water pressure of 5,000 psi until all loose and deteriorated concrete has been removed. Only silica sand and water may be used in the wet abrasive blasting. After the wet abrasive blasting has been completed, these areas shall be flushed with water at a minimum water pressure of 5,000 psi to remove any residual sand. Following the wet abrasive blasting, a dry-abrasive blasting shall be done to remove any remaining deteriorated concrete. The dry-abrasive blasting shall use only copper slag and at a minimum pressure of 90 psi. Cleaning and preparation of the manhole shall also conform to the requirements of the coating manufacturer.

If a new force main will connect into a manhole, the manhole shall have interior corrosion protection.

All extensions to manholes with existing PVC lining, shall have one of the previously specified coatings applied to both the concrete and the steel surfaces of the extension to the manhole. For the purpose of this note, a diversion structure will be considered a manhole.

Interior corrosion protection shall be applied to the walls, benches and flow channels. All surfaces shall be cleaned and prepared in accordance with the coating manufacturer's recommendations. Concrete surfaces that may be contaminated with oils, grease, or other substances, shall be scarified or chemically cleaned. All cracks and voids shall be filled with an underlayment to provide a smooth surface. All manhole joints, and cracks that exist between the manhole steps and the wall, shall be caulked using a hybrid novolac-epoxy caulk, or other Approved caulk. Trowel marks and other minor surface irregularities shall be removed from all surfaces that will be coated. Any new concrete added to the surface shall receive a dry abrasive brush-off blasting using a minimum pressure of 90 psi to lightly abrade the surface and open up subsurface holes and voids and etch the surface sufficiently (to approximately a 60 grit sandpaper texture) to allow the coating to bond satisfactorily.

An epoxy primer/sealer coat shall be applied to all concrete surfaces before the final coating is applied. The temperature of the existing concrete surfaces shall not vary 15° F or greater, from the top to the bottom of the manhole. The epoxy primer/sealer shall be applied in accordance with the manufacturer's instructions.

The final coating shall be applied with a minimum dry film thickness coating of 3/16 inches. Spray application of coatings will be allowed if the spray equipment complies with the coating manufacturer's recommendations. A rougher surface shall be provided for the bench by using a short nap mohair paint roller. After the coating has been applied, all surfaces shall be tested for Holidays utilizing a dry conductive probe with a minimum of 17,000 volts. If no Holidays are found, a certification shall be submitted to the Field Engineer.

The Contractor that will apply the coating for the interior corrosion resistance of manholes shall meet the following requirements:

- Provide a performance history showing a minimum experience of 5 years in applying either the specified coating or an equivalent coating used in the wastewater industry;
- Have a current AE type license with the Arizona Registrar of Contractors for the application of specialized coatings for sanitary sewer manholes;
- Provide a certification from the manufacturer for the application of the coating that will be applied;
- Provide 3 references relating to the quality of workmanship performed on other Projects that use the same coating that will be applied or an equivalent coating;
- Provide a 3-year warranty, from the date of Construction Acceptance. The warranty shall include a bond that is payable to the Department. The bond shall cover both the material costs and the labor costs associated with the coating. The bond shall be unconditional in nature covering any type of failure in the coating. The bond shall agree to repair or replace the coating at no cost to the Department. The bond and warranty shall not apply to manhole frames and covers. Due to the limits on available bonding terms for coatings, the Contractor may supply a two-year bond, followed by a one-year bond;
- Provide a warranty from the coating manufacturer that is addressed to the bonding company and the Department. At a minimum, the warranty shall state that if the coating is applied in accordance with the manufacturer's recommendations, it will not fail for a period of 5 years, while the coating is immersed in either an acidic or an alkaline solution that is maintained at a temperature of 85° F. The acidic solution shall be considered a 10% by weight concentration of sulfuric acid. The alkaline solution shall be considered a 25% by weight concentration of sodium hydroxide. Blistering, cracking, brittleness or softening of the coating shall constitute failure;

The Department will conduct inspections of the coating and may request any necessary corrections, prior to expiration of the bond.

E. Abandonment of Manholes

Brick manholes to be abandoned-in-place shall be demolished to an elevation at least 3 feet below finished grade. Precast concrete manholes to be abandoned-in-place shall remove the top cone or riser section. The interior of the manhole shall be cleaned and sterilized prior to being filled with backfill material. Backfill material shall conform to Table 1 of S.D. RWRD-104 and be installed in accordance with Subsection 3.1.3(E). The manhole frame and cover shall be salvaged, cleaned and delivered to the Department. All manholes that are abandoned in place shall be marked with a marker per S.D. RWRD-503.

Debris generated by the removal of existing Public Sewer manholes shall be removed from the site by the Contractor and disposed of at an appropriate solid waste facility. The Contractor shall furnish the Field Engineer the original copy of the dumping receipt. The manhole and disturbed areas shall be backfilled with select material and compacted in accordance with the standards set by the Agency controlling the Right-of-Way. In all cases a minimum density of 95% of the standard proctor density, in accordance with the provisions of the Arizona Test Method 225, shall be achieved.

3.4 Other Sanitary Sewer Appurtenances

3.4.1 Piles

Piles for supporting sanitary sewer pipe shall conform to the requirements of S.S.D. RWRD-101. All steel plates shall conform to ASTM A36/A36M. All welding electrodes shall conform to ASTM 233-62T and AWS A5.1 grade E70XX. All bolts and nuts shall conform to ASTM A307/A307M.

3.4.2 Casing Pipe

- A. Steel casing pipe for Public Sewer lines shall conform to ASTM A36, A53, A139, API 5L Gr B, 5L X42, or 5L X52. Casing pipe shall have a minimum yield strength of 35,000 pounds per square inch. Welding shall use matching filler metal requirements as listed in AWS D1.1 Table 3.1. Shop and field joints shall be continuous circumferential welds in accordance with AWS D1.1/D1.1M and be performed by AWS D1.1 qualified personnel.
- B. Casing pipe shall be square cut and have dead-even lengths which are compatible with the jack and bore equipment. Any section of pipe showing signs of failure shall be replaced. All leaking joints shall be repaired at no additional cost to Pima County.
- C. In no case shall the casing pipe be less than 0.5 inch thick unless otherwise specified on the project. Pipe wall thickness for Union Pacific Railroad (UPRR) crossings shall be per UPRR requirements.
- D. The casing shall provide a minimum of six (6) inches of clearance from the carrier pipe bell or a minimum of three (3) inches of clearance from the carrier pipe restraint harness, whichever provides the greater casing pipe diameter.
- E. Two (2) inch grout connections shall be provided at a maximum spacing of twenty (20) feet at the 12 o'clock position in the steel casing pipe. Upon completion of the boring operation the contractor shall inspect each grout hole to determine if grouting is required. Any void greater than two (2) inches outside the casing will require grouting.

All casing spacers and end seals shall be Approved and installed in accordance with S.D. RWRD-100 and the manufacturer's recommendations. Refer to the Department's List of Approved Products for the recommended casing spacers and end seals.

3.4.3 List of Approved Products for Public Sewers

For a current List of Approved Products for Public Sewers, check the Department's website at: www.pima.gov/wwm/eng/ or contact the Field Engineering section.



SECTION 4 **STANDARD DETAILS**

Standard Specifications and Details for Construction

	<u>DETAIL NO.</u>	<u>DETAIL NAME</u>
SEWER PLANS	RWRD 001	GENERAL NOTES
GRAVITY SEWER LINES & EASEMENTS	RWRD 100	CASING FOR SEWER LINES
	RWRD 101	PILE-SUPPORTED SEWER LINES
	RWRD 102	SEWER LINE REPAIR
	RWRD 103	COUPLING FOR UNLIKE PIPE MATERIALS
	RWRD 104	TYPICAL TRENCH FOR GRAVITY SEWER LINES
	RWRD 105-106	(INTENTIONALLY OMITTED)
	RWRD 107	DEFLECTION TESTING MANDREL
	RWRD 108	SEWER/WATER CROSSING DETAILS
	RWRD 109	TURNING RADII FOR SEWER EASEMENTS
	RWRD 110	RIGHT ANGLE TURN AROUND FOR SEWER EASEMENTS
	RWRD 111	TYPICAL SEWER EASEMENT
	RWRD 112	SEWER EASEMENTS IN ENVIRONMENTALLY SENSITIVE AREAS
	RWRD 113	SCOUR PROTECTION FOR SEWER LINES
MANHOLES	RWRD 200	PRECAST MANHOLE BASE
	RWRD 201	CAST-IN-PLACE MANHOLE BASE
	RWRD 202	MANHOLE FLOW CHANNELS
	RWRD 203	BLOCK-OUTS
	RWRD 204	(INTENTIONALLY OMITTED)
	RWRD 205	4' DIAMETER MANHOLE CONFIGURATIONS
	RWRD 206	5' DIAMETER MANHOLE CONFIGURATIONS
	RWRD 207	SHALLOW MANHOLES
	RWRD 208	MANHOLE JOINTS
	RWRD 209	REINFORCED MANHOLE JOINTS
	RWRD 210	MANHOLE STEPS CONFIGURATION
	RWRD 211	CONCRETE COLLAR FOR PAVED AREAS
	RWRD 212	CONCRETE COLLAR FOR UNPAVED AREAS
	RWRD 213	24" FRAME AND COVER
	RWRD 214	24" WATERTIGHT FRAME AND COVER
	RWRD 215	24" BOLTED WATERTIGHT FRAME AND COVER
	RWRD 216	30" FRAME AND COVER
	RWRD 217	30" WATERTIGHT FRAME AND COVER
	RWRD 218	30" BOLTED WATERTIGHT FRAME AND COVER
	RWRD 219-222	(INTENTIONALLY OMITTED)
	RWRD 223	MANHOLE VENT ASSEMBLY
	RWRD 224	MODIFIED MANHOLE VENT ASSEMBLY
	RWRD 225	(INTENTIONALLY OMITTED)
	RWRD 226	CONCRETE WEIR FOR DIVERSION MANHOLES
	RWRD 227	(INTENTIONALLY OMITTED)
	RWRD 228	REDWOOD ISOLATION GATE
	RWRD 229	(INTENTIONALLY OMITTED)
RWRD 230	(INTENTIONALLY OMITTED)	
RWRD 231	INTERNAL DROP MANHOLE CONNECTION	
RWRD 232	TEMPORARY CLEANOUT FOR PHASED PROJECTS	

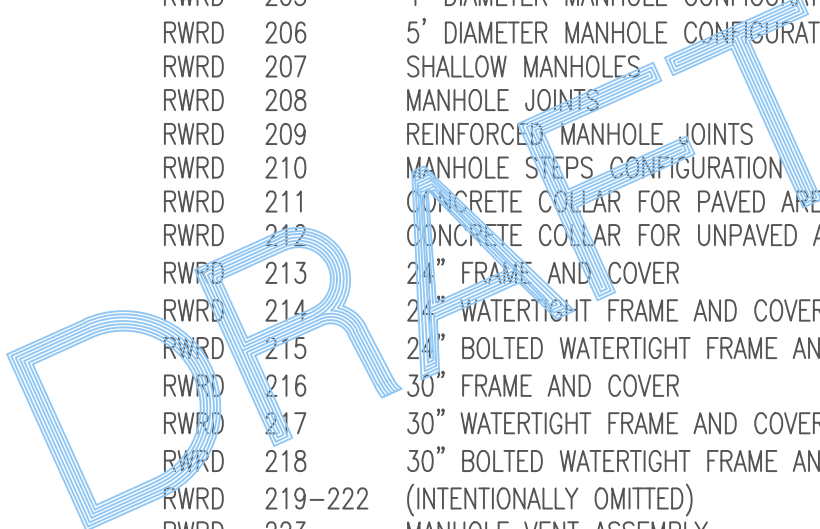

ISSUED:	STANDARD DETAIL SHEET INDEX		DETAIL NO.
1/94			
REVISED:			
02/21			SHEET 1 OF 2

DETAIL NO. DETAIL NAME

MODIFICATION OF EXISTING SEWER FACILITIES

RWRD	300	CONNECTION TO EXISTING MANHOLE BARREL
RWRD	301	CONNECTION TO EXISTING MANHOLE BASE
RWRD	302	RAISE EXISTING BENCH
RWRD	303	NEW MANHOLE OVER EXISTING SEWER LINE
RWRD	304	GRADE ADJUSTMENT FOR EXISTING BRICK MANHOLE
RWRD	305	GRADE ADJUSTMENT FOR EXISTING PRECAST MANHOLE
RWRD	306	FLOW CHANNEL COVER
RWRD	307	GRADE ADJUSTMENT FOR EXISTING CLEANOUTS
RWRD	308	LEVELING COURSE FOR BRICK MH RECONSTRUCTION
RWRD	309	MANHOLE RECONSTRUCTION

SERVICE LATERALS

RWRD	400	HCS REROUTING
RWRD	401	HCS CONNECTION TO SEWER LINE
RWRD	402	HCS CONNECTIONS TO MANHOLES
RWRD	403	(INTENTIONALLY OMITTED)
RWRD	404	HCS CLEANOUTS
RWRD	405	HCS ABANDONMENT

WASTEWATER PUMPING SYSTEMS

RWRD	500	TYPICAL TRENCH FOR FORCE MAINS
RWRD	501	FORCE MAIN TEST STATION
RWRD	502	FORCE MAIN CONNECTION TO MANHOLE
RWRD	503	FORCE MAIN AND ABANDONMENT MONUMENTS
RWRD	504	EQUIPMENT SUPPORT AND SHADE STRUCTURE

DRAFT

ISSUED:	STANDARD DETAIL	DETAIL NO.
1/94	SHEET INDEX	
REVISED:		
02/21		
		SHEET 2 OF 2

1. ANY CONSTRUCTION ACTIVITY HAVING THE POTENTIAL TO DAMAGE EXISTING PUBLIC SANITARY SEWERS OR ANY ACTIVITY THAT REQUIRES MATERIALS OR EQUIPMENT TO ENTER EXISTING PUBLIC SANITARY SEWERS SHALL REQUIRE A PIMA COUNTY RWRD SEWER CONSTRUCTION PERMIT PRIOR TO COMMENCING THAT ACTIVITY.
2. THE CONTRACTOR SHALL SUBMIT A FLOW MANAGEMENT PLAN (FMP) TO PCRWRD FIELD ENGINEERING FOR APPROVAL BEFORE PROCEEDING WITH ANY WORK THAT MAY AFFECT LIVE SEWERS. THE FMP SHALL IDENTIFY AND INCLUDE ALL FLOW MANAGEMENT COSTS IN THE CONSTRUCTION BID. THE FMP SHALL BE SUBMITTED THIRTY (30) CALENDAR DAYS PRIOR TO THE SEWER PRE-CONSTRUCTION MEETING. FIELD ENGINEERING WILL REVIEW THE FMP WITHIN TEN (10) BUSINESS DAYS TO ACCOMMODATE REVIEW AND REVISION CYCLES. REFER TO PCRWRD SSDC 2022, SECTION 2 FOR FMP REQUIREMENTS. PLEASE CONTACT PCRWRD FIELD ENGINEERING AT (520) 724-2651 FOR ANY QUESTIONS REGARDING FLOW MANAGEMENT.
3. THE CONTRACTOR SHALL FURNISH, OPERATE AND MAINTAIN ALL EQUIPMENT AND LABOR NECESSARY TO PROVIDE CONTINUOUS 24 HOURS PER DAY SANITARY SEWER SERVICE TO ALL PARTIES TRIBUTARY TO A LIVE SEWER TO WHICH A CONNECTION IS TO BE MADE.
4. THE INSPECTION OF THE CONTRACTOR'S WORK BY AN AGENCY AND/OR PCRWRD STAFF SHALL IN NO WAY RELIEVE THE CONTRACTOR OF THE RESPONSIBILITY FOR COMPLIANCE WITH THE REQUIREMENTS OF THE APPROVED CONTRACT DOCUMENTS. IF THE DESIGN ENGINEER OR PCRWRD STAFF FAIL TO POINT OUT A DEFECT, DEFICIENCY OR ERROR IN THE WORK FROM LACK OF DISCOVERY OR ANY OTHER REASON, IT SHALL NOT PREVENT LATER REJECTION OR RELIEVE THE CONTRACTOR OF PERFORMING CORRECTIONS TO THE UNSATISFACTORY WORK WHEN DISCOVERED. THE CONTRACTOR SHALL NOT FILE A CLAIM FOR LOSSES SUFFERED DUE TO ANY NECESSARY REMOVALS OR REPAIRS RESULTING FROM THE UNSATISFACTORY WORK.
5. ANY SEWER CONSTRUCTION WORK THAT IS NOT INCLUDED IN THE APPROVED SEWER PLANS WILL NOT BE ACCEPTED BY PCRWRD. SEE PCRWRD SSDC 2022, SECTION 1.4.5 REGARDING THE APPROVAL OF FIELD CHANGES.
6. CONCERNS REGARDING THE ACCURACY BETWEEN THE UNDERGROUND FACILITY MARKINGS AND THE PROJECT PLANS SHALL BE IMMEDIATELY REPORTED TO THE DESIGN ENGINEER.
7. CONTRACTOR SHALL MAINTAIN ACCESS TO ALL SANITARY SEWER MANHOLES AT ALL TIMES.
8. THE CONTRACTOR SHALL FIELD VERIFY EXISTING SEWER LINE ELEVATIONS AND ALIGNMENTS PRIOR TO CONSTRUCTION. VERIFICATION MAY REQUIRE POT-HOLING.
9. ANY HOUSE CONNECTION SEWER (HCS) OR BUSINESS CONNECTION SEWER (BCS) LINES ENCOUNTERED DURING CONSTRUCTION SHALL BE PROTECTED, REPAIRED, OR REROUTED, AS THE SITUATION DICTATES, PER PCRWRD SSDC 2019 DETAIL NO. RWRD 400 AND AT NO EXPENSE TO THE PROPERTY OWNER OR PCRWRD. HCS AND BCS LINES ARE NOT OWNED OR MAINTAINED BY PCRWRD. PRIVATE CONNECTION SEWERS CONSTRUCTED PRIOR TO JANUARY 2006 ARE NOT REQUIRED TO BE LOCATED AND MARKED.
10. SURVEY LAYOUT AND SURVEY CONTROL SHALL BE PERFORMED BY, OR UNDER, THE DIRECT SUPERVISION OF AN ARIZONA RLS.
11. SURVEY CUT SHEETS SHALL BE PREPARED IN ACCORDANCE WITH PCRWRD SSDC 2022, SECTION 3.2.3(A)(I). CERTIFIED CUT SHEETS SHALL BE SUBMITTED TO THE PCRWRD FIELD ENGINEER PRIOR TO COMMENCEMENT OF SEWER CONSTRUCTION. CUT SHEETS ARE FOR PCRWRD REFERENCE ONLY AND SHALL NOT DELAY SEWER CONSTRUCTION DUE TO REVIEW OF THE DELIVERABLE. ANY ERRORS OR OMISSIONS RESULTING IN IMPROPER SEWER CONSTRUCTION SHALL NOT BE THE RESPONSIBILITY OF PCRWRD. REFER TO PCRWRD SSDC 2022, SECTION 3.2.3(A)(II) FOR CONSTRUCTION SURVEY STAKING REQUIREMENTS.

DRAFT

ISSUED:	STANDARD DETAIL		DETAIL NO.
06/17	GENERAL NOTES		RWRD 001
REVISED:			
12/21			SHEET 1 OF 2

12. AS-BUILT PLANS SHALL CONFORM TO SSDC 2022, SECTION 1.4.7 AND ARE REQUIRED FOR FINAL ACCEPTANCE OF SEWER CONSTRUCTION BY PCRWRD.
13. NEW PUBLIC SANITARY SEWER FACILITIES MUST BE TESTED, INSPECTED AND AUTHORIZED FOR DISCHARGE BY PCRWRD AND ADEQ. OR IT'S DELEGATE, PRIOR TO DISCHARGING INTO THE EXISTING PUBLIC SANITARY SEWER SYSTEM.
14. PRIOR TO THE INSTALLATION OF SANITARY SEWERS, ALL ROUGH GRADING, INCLUDING FILL, SHALL BE COMPLETED TO A MINIMUM OF 3 FEET OVER THE TOP OF THE SEWER PIPE, BEDDING, SHADING, AND TRENCH BACKFILL COMPACTION SHALL BE PERFORMED IN ACCORDANCE WITH PCRWRD SSDC 2022, DETAIL NO. RWRD 104, OR AS SHOWN ON THE PLANS. SHOULD GROUND WATER OR UNANTICIPATED SOIL CONDITIONS BE ENCOUNTERED, THE BEDDING SHALL BE MODIFIED BY THE DESIGN ENGINEER AND APPROVED BY THE PCRWRD FIELD ENGINEER. WHEN THE NEW SEWER IS LOCATED WITHIN A PUBLIC SEWER EASEMENT, COMPACTION OF BACKFILL SHALL BE IN ACCORDANCE WITH THE CONSTRUCTION DOCUMENTS OR AS OTHERWISE DIRECTED BY PCRWRD. WHEN THE NEW SEWER IS LOCATED WITHIN RIGHT-OF-WAY AGENCY HAVING JURISDICTION.
15. SANITARY SEWER CONSTRUCTION SHALL START AT THE LOWEST DOWNSTREAM POINT AND PROCEED UPSTREAM, REGARDLESS OF THE STATIONING PLANS. IF CONSTRUCTION CANNOT BE PERFORMED IN THIS MANNER, THE CONTRACTOR SHALL PROVIDE AN OUT-OF-SEQUENCE LETTER FOR APPROVAL BY THE PCRWRD FIELD ENGINEER PRIOR TO THE START OF SEWER CONSTRUCTION.
16. THE HORIZONTAL AND VERTICAL SEPARATION BETWEEN PUBLIC WATER MAINS AND PUBLIC SEWER LINES SHALL COMPLY WITH ARIZONA ADMINISTRATIVE CODE (A.A.C.) R18-5 502 AND PCRWRD SSDC 2022, DETAIL NO. RWRD 108.
17. PLANTING WITHIN PUBLIC SEWER EASEMENTS SHALL ONLY BE ALLOWED WITH DSD APPROVAL. TREES WITH BRANCHES OR ROOTS HAVING THE POTENTIAL TO EXTEND INTO PUBLIC SEWER EASEMENTS SHALL BE AVOIDED. IN CASES WHERE THE PUBLIC SEWERS MUST BE LOCATED OUTSIDE PAVED OR STABILIZED AREAS, LANDSCAPING AND PLANTING SHALL ADHERE TO GUIDELINES IN PCRWRD EDS 2022, SECTION 7.7 AND PCRWRD SSDC 2022, DETAILS NO. RWRD 111 AND 112.
18. ALL PROJECT ACTIVITIES MUST BE KEPT WITHIN THE PROJECT AREAS, CONCERNING HUMAN BURIAL REMAINS, ARCHAEOLOGICAL CLEARANCE RECOMMENDATIONS DO NOT EXEMPT THE DEVELOPMENT FROM COMPLYING WITH STATE BURIAL PROTECTION LAWS. IN THE EVENT THAT HUMAN REMAINS, INCLUDING HUMAN SKELETAL REMAINS, CREMATIONS, CEREMONIAL OBJECTS OR FUNERARY OBJECTS ARE FOUND DURING EXCAVATION OR CONSTRUCTION, GROUND DISTURBING ACTIVITIES MUST CEASE IN THE IMMEDIATE VICINITY OF THE DISCOVERY. ARIZONA STATE LAWS ARS 41-844 AND 41-865 REQUIRE THAT THE ARIZONA STATE MUSEUM BE NOTIFIED OF THE DISCOVERY AT (520) 621-4795 SO THAT CULTURAL GROUPS WHO CLAIM CULTURAL OR RELIGIOUS AFFINITY TO THE REMAINS CAN MAKE APPROPRIATE ARRANGEMENTS FOR THE REPATRIATION AND REBURIAL OF THE REMAINS. THE HUMAN REMAINS WILL BE REMOVED FROM THE SITE BY A PROFESSIONAL ARCHAEOLOGIST PENDING CONSULTATION AND REVIEW BY THE ARIZONA STATE MUSEUM AND THE CONCERNED CULTURAL GROUPS.

DRAFT

ISSUED:	STANDARD DETAIL		DETAIL NO.
06/17	GENERAL NOTES		RWRD 001
REVISED:			
12/21			SHEET 2 OF 2

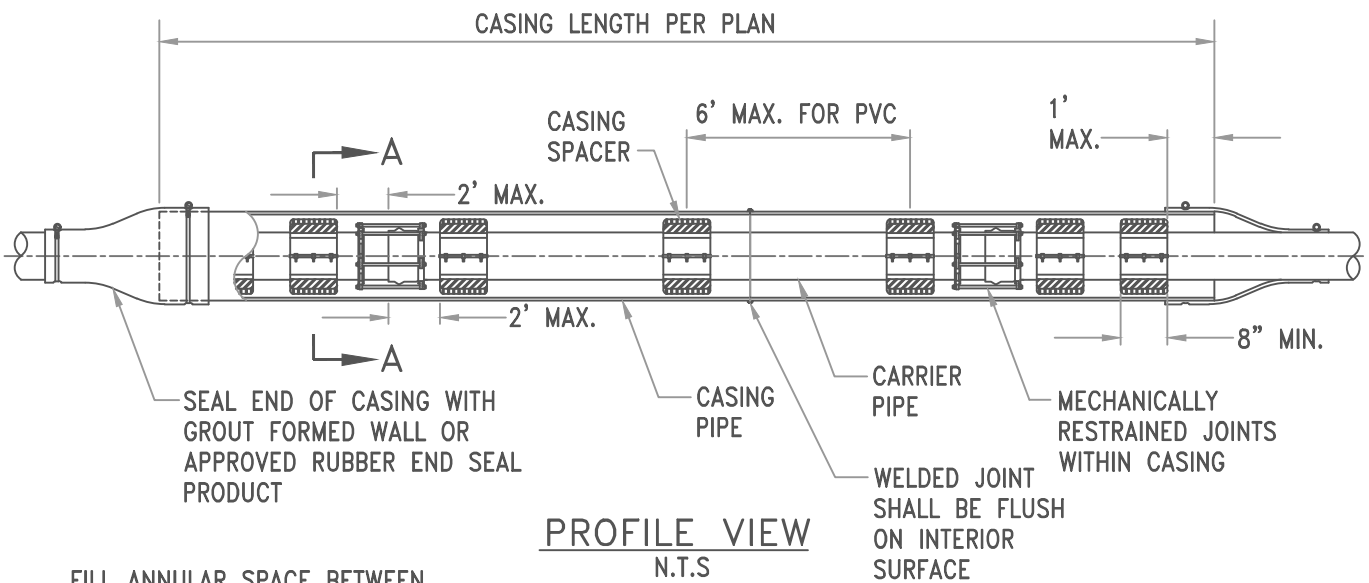

FILL ANNULAR SPACE BETWEEN CASING AND CARRIER PIPE WITH SAND OR 3/8" PEA GRAVEL UNLESS OTHERWISE INDICATED ON THE PLANS OR APPROVED BY THE FIELD ENGINEER

APPROVED CASING SPACER WITH NON-CONDUCTIVE RUNNERS

1" MIN. CLEARANCE (TYP.)

CARRIER PIPE-PVC OR HDPE (SDR/DR PER PLAN)

PRESSURE GROUT VOIDS (TYP). SEE SUB-SEC. 3.4.2(e) STD. SPECS.

STEEL CASING PIPE, SEE NOTE 2

CENTERED AND RESTRAINED CONFIGURATION UNLESS OTHERWISE APPROVED

SECTION A-A
N.T.S.

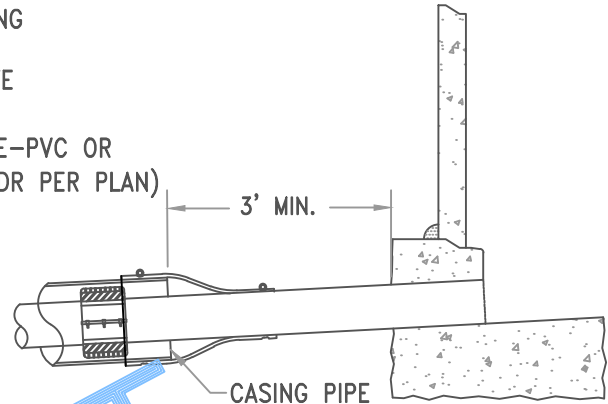

MINIMUM DISTANCE FROM MANHOLE
N.T.S.

NOTES:

1. THIS DETAIL APPLIES TO GRAVITY SEWER LINES WITH DIAMETERS UP TO AND INCLUDING 24". FOR CARRIER PIPE GREATER THAN 24" IN DIAMETER OR FORCE MAINS, CASING DETAILS SHALL BE IN ACCORDANCE WITH THE PLANS OR SUBMITTED TO THE FIELD ENGINEER FOR APPROVAL.
2. CASING PIPE WALL THICKNESS SHALL BE 1/2" MINIMUM PER SUBSECTION 3.4.2(c), SSDC UNLESS OTHERWISE INDICATED ON THE PLANS.
3. SEE SUBSECTION 3.4.2(d) SSDC FOR MINIMUM CASING PIPE DIAMETER..
4. UNDER NO CIRCUMSTANCE SHALL WOOD SKIDS OR FULLY-METAL CASING SPACES BE PERMITTED.
5. FOR A CURRENT LIST OF APPROVED PRODUCTS, CONTACT THE DEPARTMENT'S FIELD ENGINEERING OFFICE.

ISSUED:	STANDARD DETAIL		DETAIL NO.	
12/12			RWRD 100	
REVISED:			CASING FOR SEWER LINES	SHEET 1 OF 1
02/21				

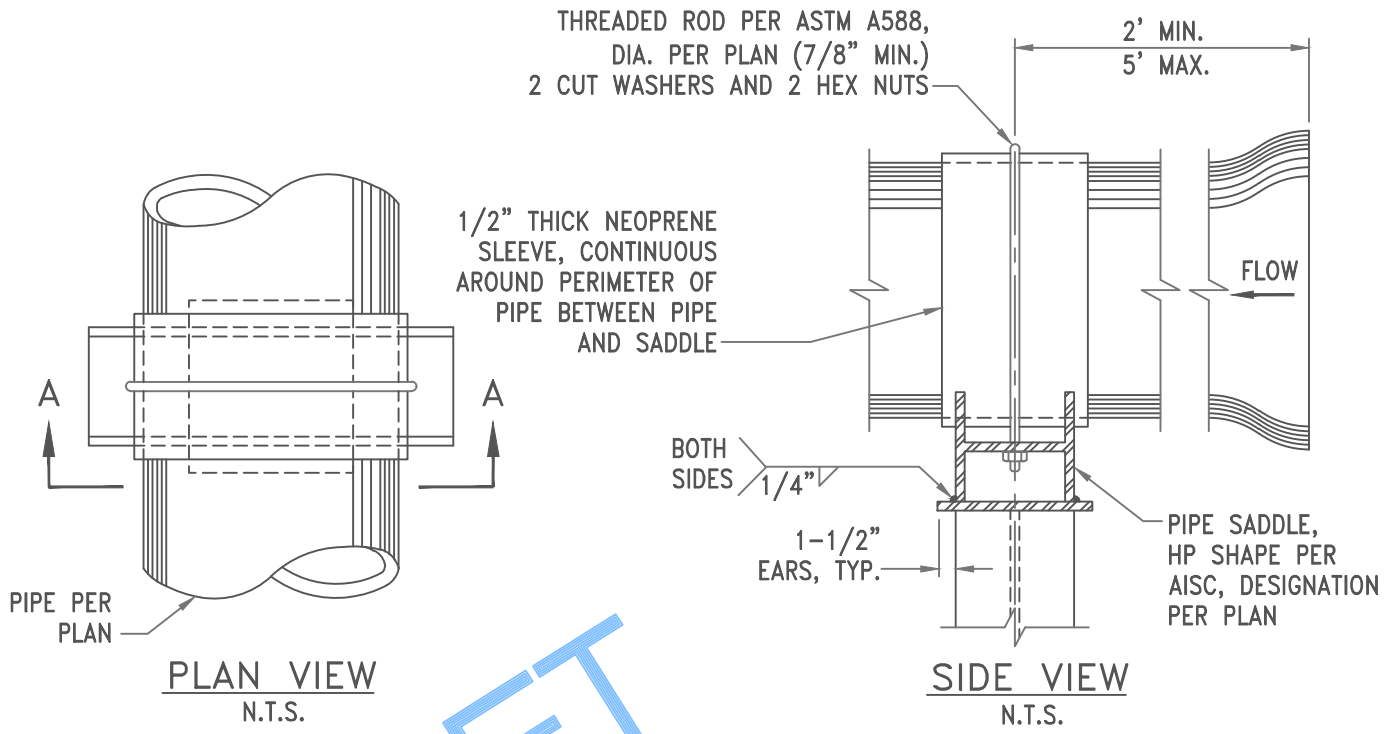

DRAFT

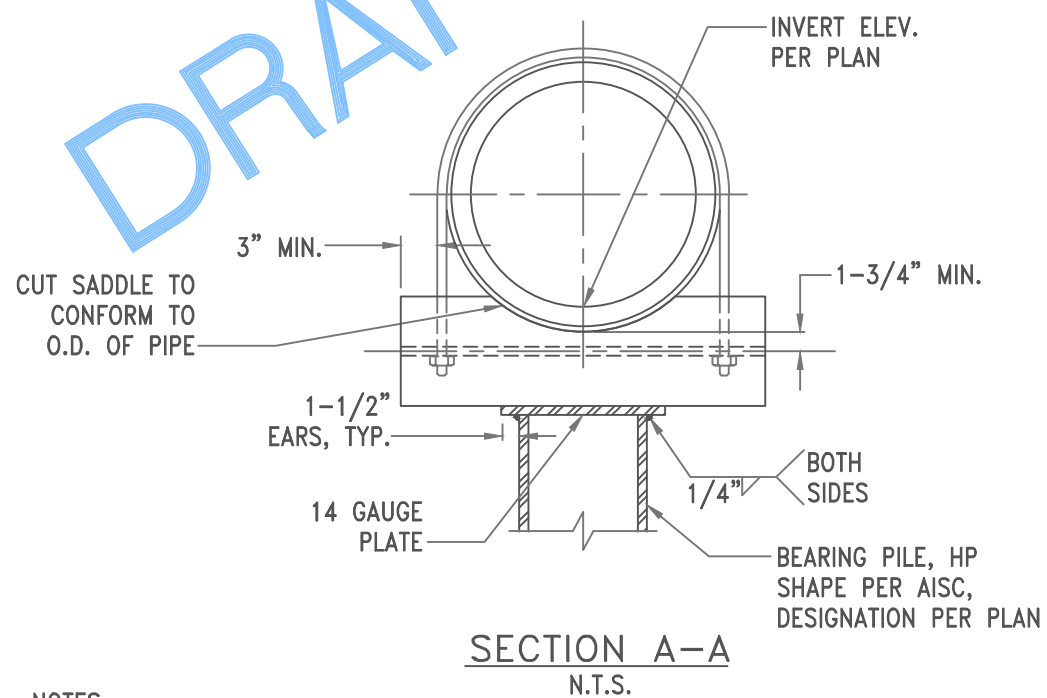

- NOTES:**
1. THIS STANDARD DETAIL MAY BE USED BY THE CONTRACTOR IF APPROVED IN THE PLANS AND IN WRITING BY PCRWRD TECHNICAL SERVICES AND ENGINEERING.
 2. SEE SUBSECTION 3.4.1 FOR MORE INFORMATION.
 3. SPECIAL CORROSION PROTECTION MEASURES SHALL BE AS SPECIFIED ON THE PLANS.

ISSUED:	STANDARD DETAIL		DETAIL NO.
8/92	PILE-SUPPORTED		RWRD 101
REVISED:	SEWER LINES		SHEET 1 OF 1
02/21			

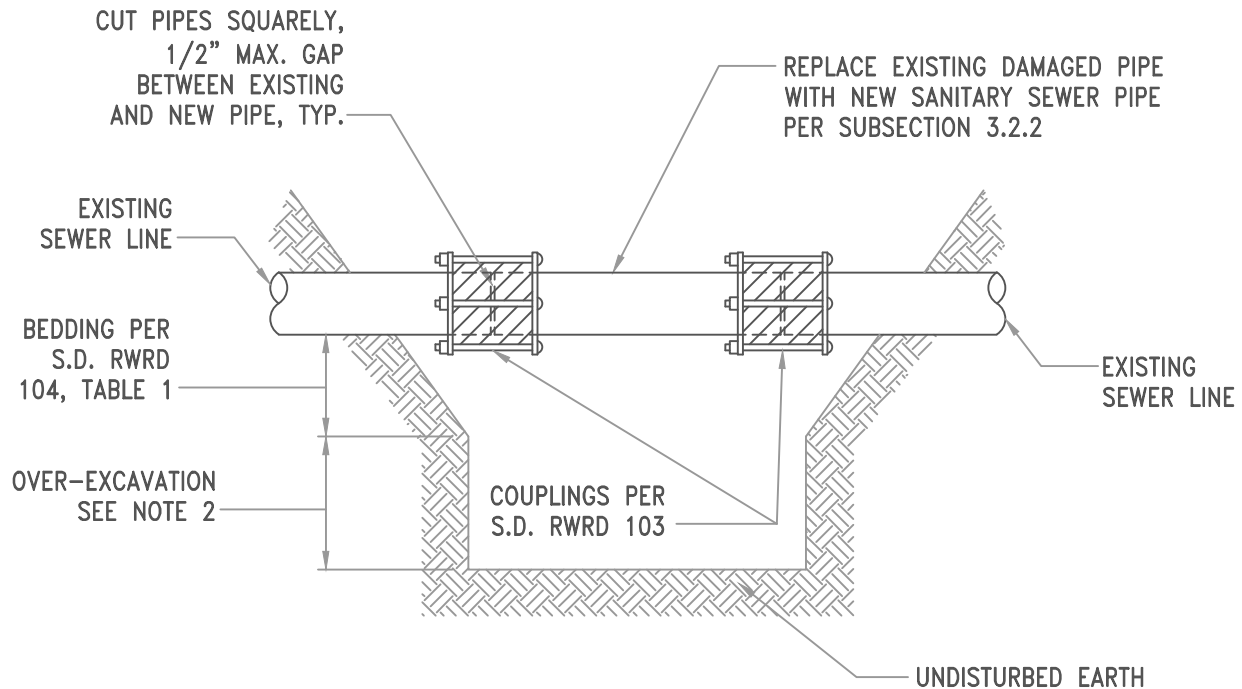

DRAFT

NOTES:

1. SEE SUBSECTION 3.2.3(G) FOR MORE INFORMATION.
2. IF SATURATED SOIL IS FOUND WHEN THE DAMAGED PORTION OF THE EXISTING SEWER REMOVED, THE SATURATED SOIL SHALL BE EXCAVATED AND REMOVED FROM THE SITE. REPLACE OVER-EXCAVATED MATERIAL WITH APPROVED FOUNDATION MATERIAL PER S.D. RWRD 104 OR AS DIRECTED BY THE FIELD ENGINEER.
3. AFTER BACKFILL INSTALLATION IS COMPLETE, CCTV INSPECTION WILL BE CONDUCTED BY THE DEPARTMENT PRIOR TO FINAL ACCEPTANCE OF THE SEWER LINE REPAIR.

ISSUED:	STANDARD DETAIL		DETAIL NO.
8/92	SEWER LINE REPAIR		RWRD 102
REVISED:			SHEET 1 OF 1
12/12			

CASTINGS SHALL BE
DUCTILE IRON PER ASTM
A536 OR STEEL PER
ASTM A36, SEE NOTE 4

HEX NUT FASTENERS
PER AWWA C111

TYPE "A" PIPE
MATERIAL



TYPE "B" PIPE
MATERIAL

WEDGE-TYPE
RUBBER GASKET
PER ASTM D2000
MBA 710, TYP.

DRAFT

NOTES:

1. COUPLINGS SHALL BE RIGID, COMPRESSION TYPE COUPLINGS AS SHOWN, APPROPRIATELY SIZED AND SUITABLE FOR SANITARY SEWER APPLICATIONS. APPROVED COUPLINGS SHALL BE IN THE DEPARTMENT'S LIST OF APPROVED PRODUCTS.
2. ADJUSTABLE REPAIR COUPLINGS (I.E. MISSION) FOR SANITARY SEWER APPLICATIONS MAY BE PERMITTED ON A CASE-BY-CASE BASIS FOR EXISTING 12" DIAMETER VCP OR CONCRETE SEWER PIPE AND SMALLER, ONLY WITH PRIOR APPROVAL BY THE FIELD ENGINEER.
3. WHERE THERE IS A 1" DIFFERENTIAL IN INTERNAL DIAMETERS OF THE 2 DIFFERENT PIPE TYPES, A SPECIAL CONNECTION, APPROVED BY THE FIELD ENGINEER, SHALL BE USED TO ELIMINATE THE DIFFERENTIAL AT THE INVERT.
4. CASTINGS SHALL HAVE AN APPROVED FACTORY-APPLIED INTERIOR AND EXTERIOR CORROSION-RESISTANT COATINGS FOR SANITARY SEWER APPLICATIONS.
5. SEE SUBSECTION 3.4.3 - FOR A CURRENT LIST OF APPROVED PRODUCTS FOR PUBLIC SEWERS, CHECK THE DEPARTMENT'S WEBSITE OR CONTACT THE FIELD ENGINEERING SECTION.

ISSUED:	STANDARD DETAIL		DETAIL NO.
8/92			RWRD 103
REVISED:	COUPLING FOR UNLIKE PIPE MATERIALS		SHEET 1 OF 1
10/15			

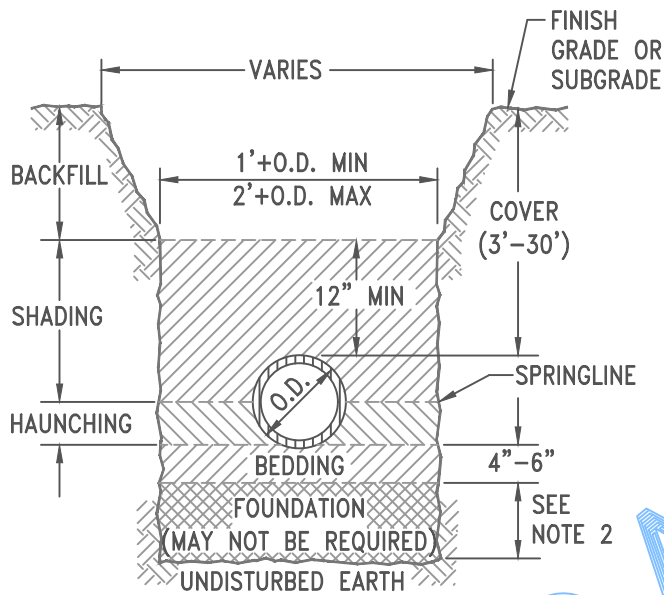

**FLEXIBLE PIPE
TRENCH DETAIL**
N.T.S.

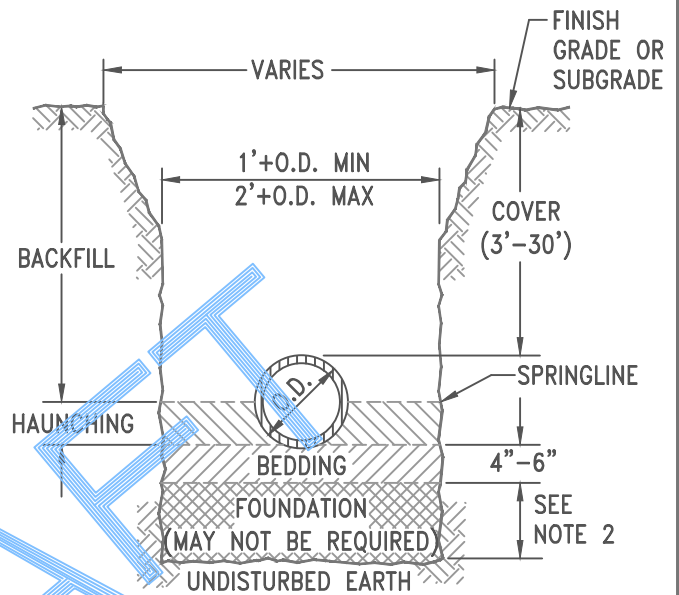

**RIGID PIPE
TRENCH DETAIL**
N.T.S.

TABLE 1: APPROVED TRENCH MATERIALS AND GRADATION REQUIREMENTS

CRUSHED STONE (FOUNDATION, BEDDING, HAUNCHING & SHADING)		SAND (BEDDING, HAUNCHING & SHADING)		EXCAVATED NATIVE MATERIAL (BACKFILL)		SELECT IMPORT MATERIAL (BACKFILL & FOUNDATION)	
NOM. SIZE	% PASSING	NOM. SIZE	% PASSING	NOM. SIZE	% PASSING	NOM. SIZE	% PASSING
1"	100	1"	100	6"	100	3"	100
3/4"	90-100	#4	60-100	ALSO SEE SUBSECTION 3.1.2(C)		3/4"	60-100
3/8"	20-55	#200	0-10			#8	35-80
#4	0-10	MAX. P.I.=5				SUM OF #200 + P.I. ≤ 25	
#8	0-5	MAX. L.L.=30				ALSO SEE SUBSECTION 3.1.2(D)	
6.0 ≤ pH ≤ 12.0		6.0 ≤ pH ≤ 12.0					
ALSO SEE SUBSECTION 3.1.2(A)		ALSO SEE SUBSECTION 3.1.2(B)					

NOTES:

- FOR SEWER LINES GREATER THAN 16 INCH DIAMETER OR COVER DEPTHS NOT CONFORMING TO THE STANDARD TRENCH DETAILS, SEE PLANS FOR MODIFIED TRENCH DETAILS.
- FOUNDATION IS REQUIRED FOR OVEREXCAVATION SUCH AS FOR ROCK OR UNSUITABLE MATERIALS. SEE SUBSECTION 3.1.3(B) FOR MORE INFORMATION.
- IN CASES WHERE GROUNDWATER IS ENCOUNTERED, INSTALLATION OF AN APPROVED GEOTEXTILE FABRIC ENCLOSING CRUSHED STONE SHALL BE REQUIRED FOR STABILIZATION.

ISSUED:	STANDARD DETAIL		DETAIL NO.	
8/92			RWRD 104	
REVISED:				SHEET 1 OF 1
02/21			TYPICAL TRENCH FOR GRAVITY SEWER LINES	

SHOP DRAWING

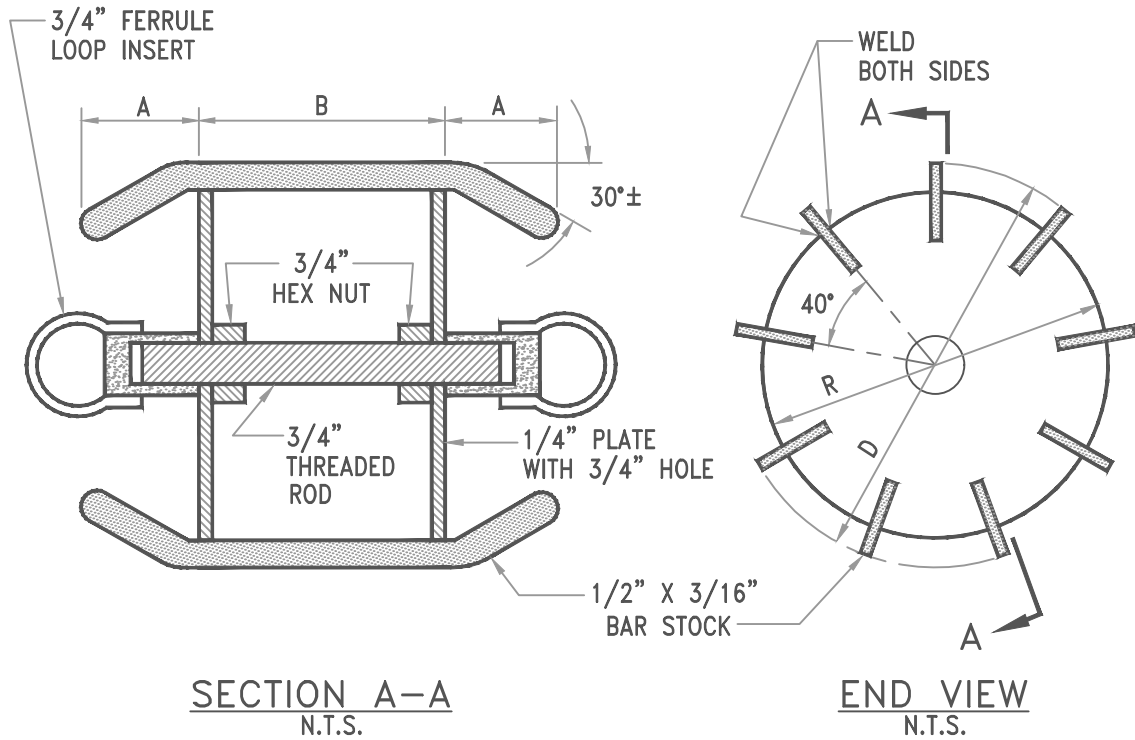

5.0% DEFLECTION LIMIT—SDR 35 PVC				
PIPE SIZE	A	B	D	R
8"	2"	2.4"–8"	7.28"	6.28"
10"	2"	3"–10"	9.08"	8.08"
12"	2"	3.5"–12"	10.79"	9.79"
15"	2"	4.3"–15"	13.20"	12.20"
18" AND OVER	SUBMIT SHOP DRAWING			

NOTES:

1. AFTER WELDING IS COMPLETED, TRUE THE OUTSIDE DIAMETER DIMENSION FOR THE FULL LENGTH OF "B" TO ± 0.010 " BY TOOL AND LATHE OR GRINDING.
2. FINISHED PART TO BE SANDBLASTED AND RUST-PROOFED WITH PAINT.
3. DEFLECTION TESTING MANDRELS SHALL BE INSPECTED AND APPROVED BY THE FIELD ENGINEER PRIOR TO USE. THE MINIMUM NUMBER OF RIBS IS SUBJECT TO APPROVAL OF THE SHOP DRAWINGS.
4. SEE SUBSECTION 3.2.3(D)(vi) FOR MORE INFORMATION.
5. FOR OTHER SDR VALUES SEE ASTM D3034-08.

DRAFT

ISSUED:	STANDARD DETAIL		DETAIL NO.
8/92	DEFLECTION TESTING MANDREL	PIMA COUNTY WASTEWATER RECLAMATION	RWRD 107
REVISED:			SHEET 1 OF 1
02/21			

VERTICAL SEPARATION

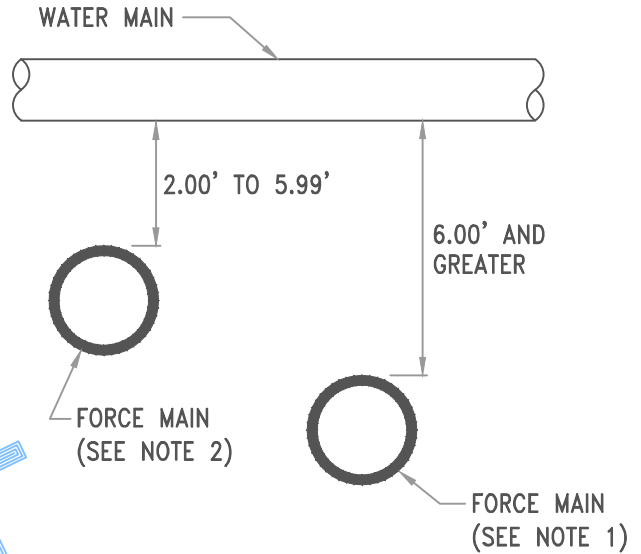
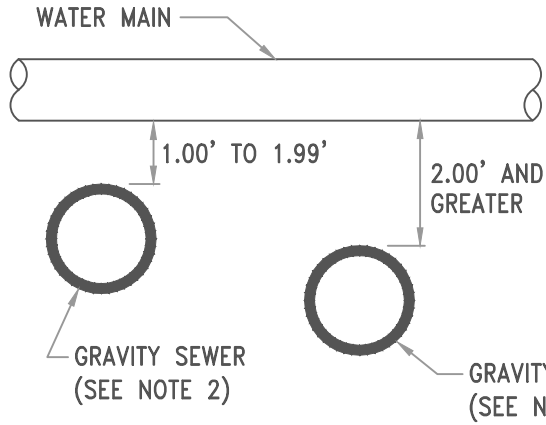

GRAVITY SEWER CROSSING

(WATER MAIN ABOVE SEWER)
N.T.S.

FORCE MAIN CROSSING

(WATER MAIN ABOVE SEWER)
N.T.S.

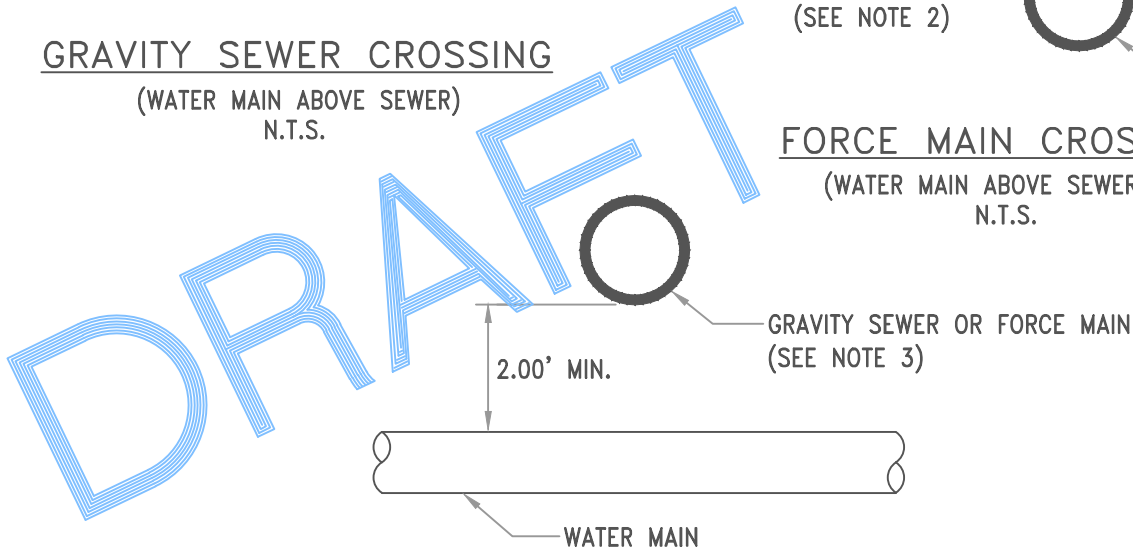

GRAVITY OR FORCE MAIN CROSSING

(WATER MAIN BELOW SEWER)
N.T.S.

NOTES:

1. WHERE A WATER MAIN CROSSES ABOVE A GRAVITY SEWER WITH 2' OR GREATER VERTICAL CLEARANCE (OUTSIDE SURFACE TO OUTSIDE SURFACE), NO EXTRA PROTECTION IS REQUIRED. WHERE A WATER MAIN CROSSES ABOVE A FORCE MAIN WITH 6' OR GREATER VERTICAL CLEARANCE, NO EXTRA PROTECTION IS REQUIRED.
2. WHERE A WATER MAIN MUST CROSS ABOVE A GRAVITY SEWER WITH LESS THAN 2' OF CLEARANCE OR ABOVE A FORCE MAIN WITH LESS THAN 6' OF CLEARANCE, CONSTRUCT OR REPLACE THE SEWER LINE WITH DUCTILE IRON PIPE (D.I.P.) OR APPROVED EQUAL. IN NO CASE SHALL THE WATER MAIN HAVE LESS THAN 1' OF CLEARANCE ABOVE A GRAVITY SEWER OR 2' OF CLEARANCE ABOVE A FORCE MAIN. IF THE JOINT IS LOCATED LESS THAN 6' FROM THE OUTSIDE SURFACE OF THE WATER MAIN, THEN A RESTRAINED JOINT OR APPROVED EQUAL SHALL BE USED. REFER TO SHEET 3 OF 3.
3. WHERE A WATER MAIN CROSSES BELOW EITHER A GRAVITY SEWER OR A FORCE MAIN, CONSTRUCT OR REPLACE THE SEWER LINE WITH D.I.P. OR APPROVED EQUAL FOLLOWING THE GUIDELINES GIVEN IN NOTE NO. 2. IN NO CASE SHALL THE WATER MAIN BE LESS THAN 2' BELOW EITHER A GRAVITY SEWER OR FORCE MAIN.

ISSUED:	STANDARD DETAIL		DETAIL NO.
8/92	SEWER/WATER		RWRD 108
REVISED:	CROSSING DETAILS		
10/15			SHEET 1 OF 3

HORIZONTAL SEPARATION

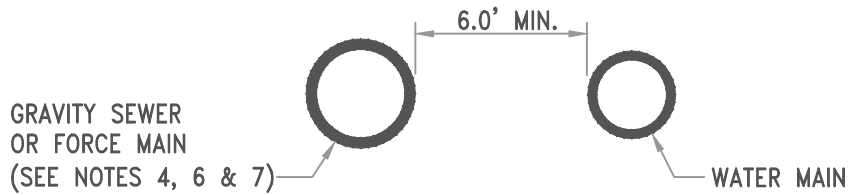

WATER MAIN SEPARATION WITH SEWER LINES

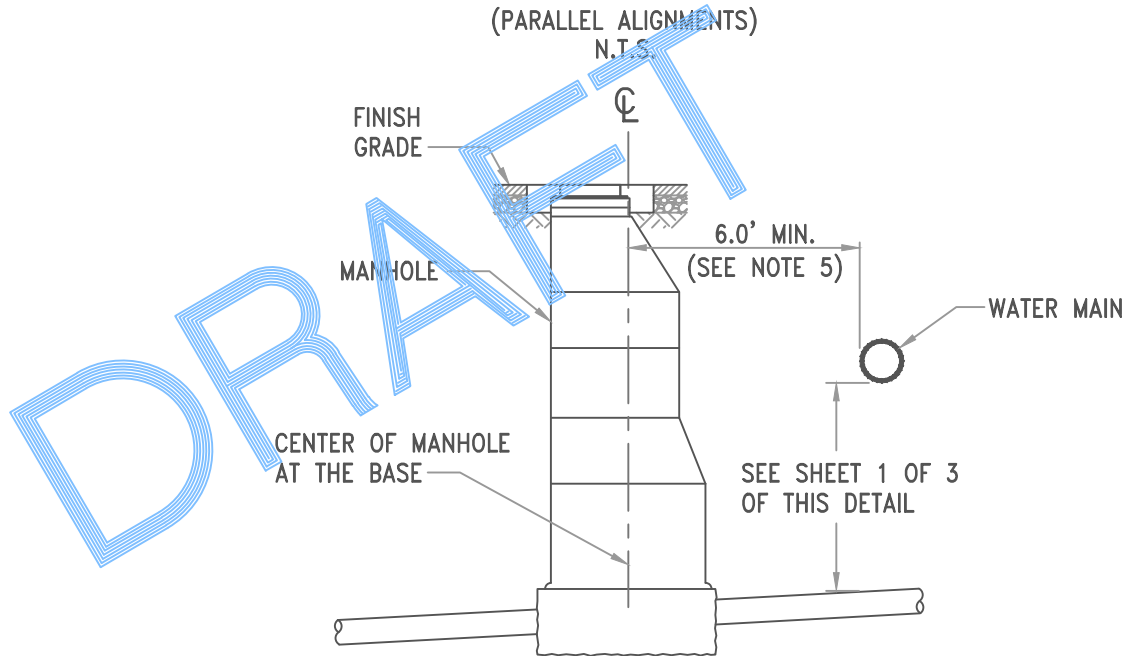

WATER MAIN SEPARATION WITH SEWER MANHOLE

N.T.S.

NOTES (CONTINUED):

4. THE MINIMUM HORIZONTAL CLEARANCE WITHOUT EXTRA PROTECTION BETWEEN A WATER MAIN AND A FORCE MAIN OR GRAVITY SEWER LINE SHALL BE 6' OUTSIDE SURFACE TO OUTSIDE SURFACE.
5. THE MINIMUM HORIZONTAL CLEARANCE BETWEEN A WATER MAIN AND A SEWER MANHOLE SHALL BE 6' FROM THE OUTSIDE SURFACE OF THE WATER MAIN TO THE CENTER OF MANHOLE.
6. WHERE A 6' HORIZONTAL CLEARANCE CANNOT BE MAINTAINED WITH A GRAVITY SEWER, CONSTRUCT OR REPLACE THE SEWER LINE WITH D.I.P. OR APPROVED EQUAL FOLLOWING THE GUIDELINES GIVEN IN NOTE NO. 2. IN NO CASE SHALL A GRAVITY SEWER LINE BE LOCATED LESS THAN 2' HORIZONTALLY FROM A WATER MAIN.
7. IN NO CASE SHALL A FORCE MAIN BE LOCATED LESS THAN 6' HORIZONTALLY FROM A WATER MAIN.
8. THE AMERICAN NATIONAL STANDARD FOR THE THICKNESS DESIGN OF D.I.P. (ANSI/AWWA C150/A21.50) SHALL BE USED TO DETERMINE THE REQUIRED PRESSURE CLASS EXCEPT FOR D.I.P. WITH A DIAMETER OF 3" THRU 24", A MINIMUM PRESSURE CLASS OF 350 IS REQUIRED. FOR D.I.P. WITH A DIAMETER GREATER THAN 24", A MINIMUM PRESSURE CLASS OF 200 IS REQUIRED.

ISSUED:	STANDARD DETAIL SEWER/WATER CROSSING DETAILS	 PIMA COUNTY WASTEWATER RECLAMATION	DETAIL NO.
8/92			RWRD 108
REVISED:			SHEET 2 OF 3
12/12			

PLAN VIEWS

N.T.S.

APPROVED COUPLING
PER S.D. RWRD 103 (TYP.)

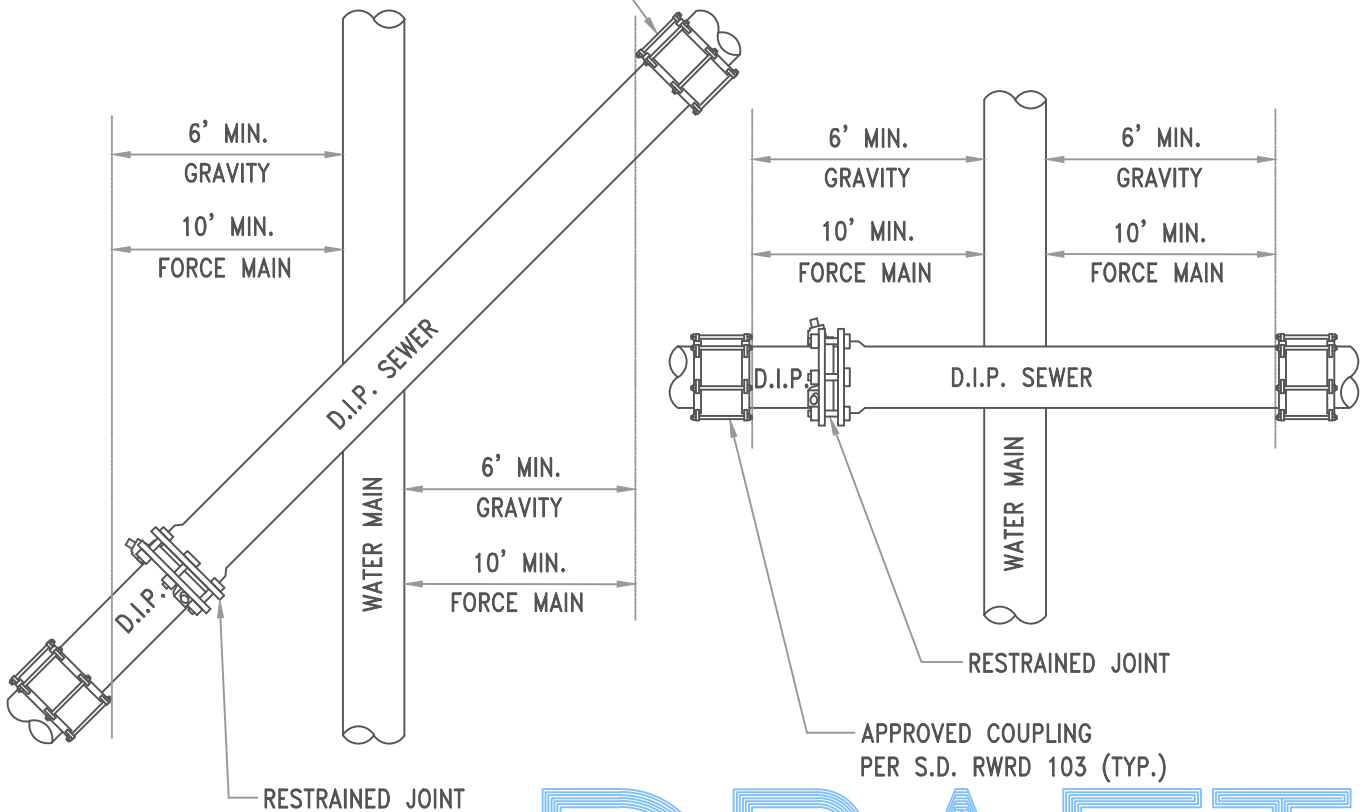

DRAFT

NOTES (CONTINUED):

9. WHERE THE SEWER LINE IS A GRAVITY SEWER, THE D.I.P. INSTALLATION OR REPLACEMENT SHALL EXTEND A MINIMUM OF 6' BEYOND EACH SIDE OF THE WATER MAIN, MEASURED HORIZONTALLY FROM AND PERPENDICULAR TO THE WATER MAIN.
10. WHERE THE SEWER LINE IS A FORCE MAIN, THE D.I.P. INSTALLATION OR REPLACEMENT SHALL EXTEND A MINIMUM OF 10' BEYOND EACH SIDE OF THE WATER MAIN, MEASURED HORIZONTALLY FROM AND PERPENDICULAR TO THE WATER MAIN.
11. WHEN UNUSUAL CONDITIONS SUCH AS, BUT NOT LIMITED TO, HIGHWAY OR BRIDGE CROSSINGS PREVENT THE WATER AND SEWER LINE SEPARATIONS REQUIRED BY THIS DETAIL FROM BEING MET, PCRWRD WILL REVIEW AND MAY APPROVE (SUBJECT TO APPROVAL BY THE ENVIRONMENTAL REGULATORY AGENCY HAVING JURISDICTION), REQUESTS FOR AUTHORIZATION TO USE ALTERNATE CONSTRUCTION TECHNIQUES, MATERIALS AND JOINTS ON A CASE-BY-CASE BASIS.
12. ALL DUCTILE IRON PIPE SHALL BE INTERNALLY LINED AND EXTERNALLY WRAPPED PER SUBSECTION 3.2.2(D).

ISSUED:	STANDARD DETAIL SEWER/WATER CROSSING DETAILS	 PIMA COUNTY WASTEWATER RECLAMATION	DETAIL NO.
8/92			RWRD 108
REVISED:			SHEET 3 OF 3
12/12			

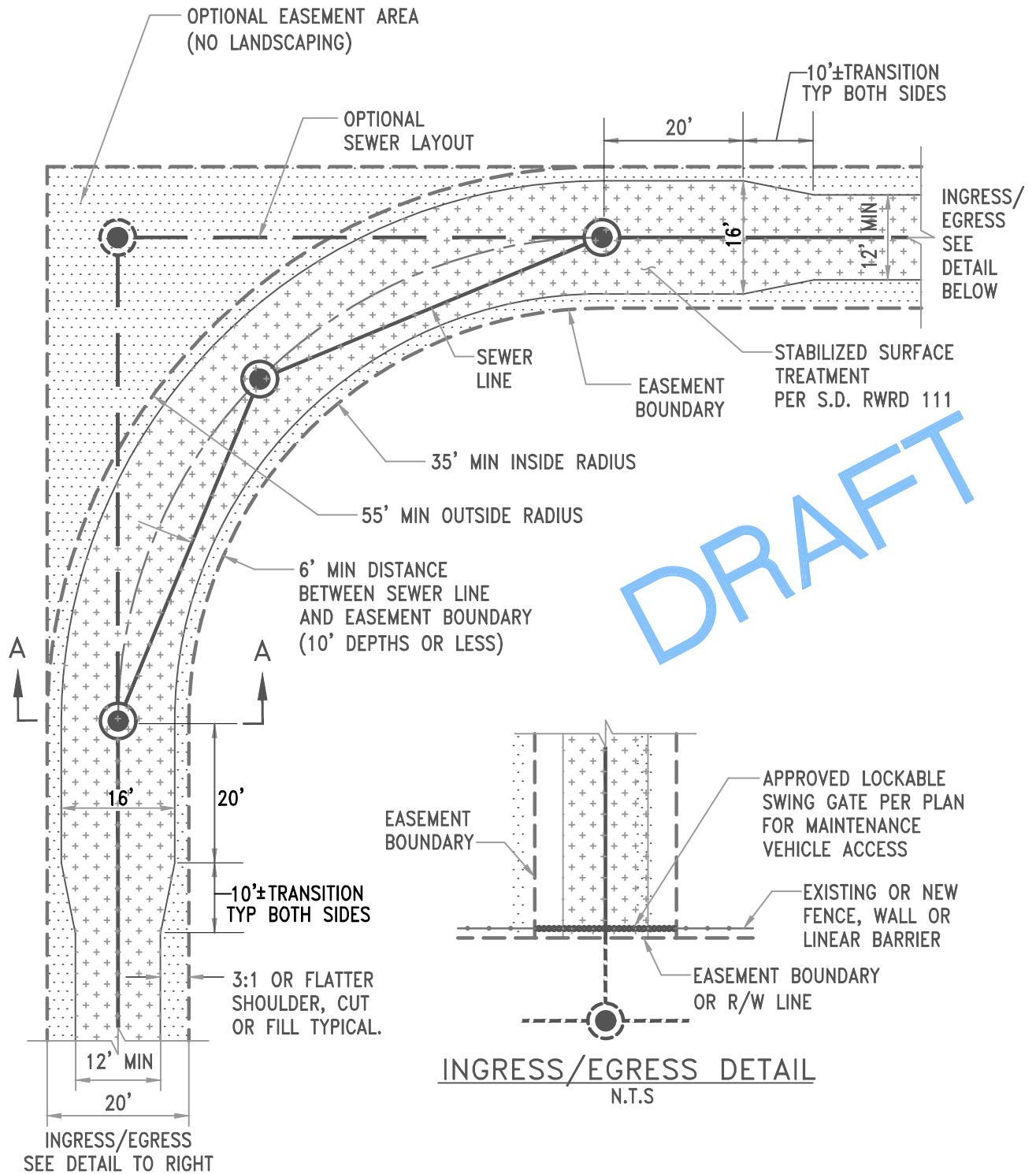

DRAFT

NOTES:

1. SEE S.D. RWRD 111 FOR SECTION A-A.
2. SEE THE DESIGN STANDARDS, SUBSECTION 7.1 FOR MORE INFORMATION.

ISSUED:	STANDARD DETAIL		DETAIL NO.
8/92	TURNING RADII FOR SEWER EASEMENTS		RWRD 109
REVISED:			SHEET 1 OF 1
02/21			

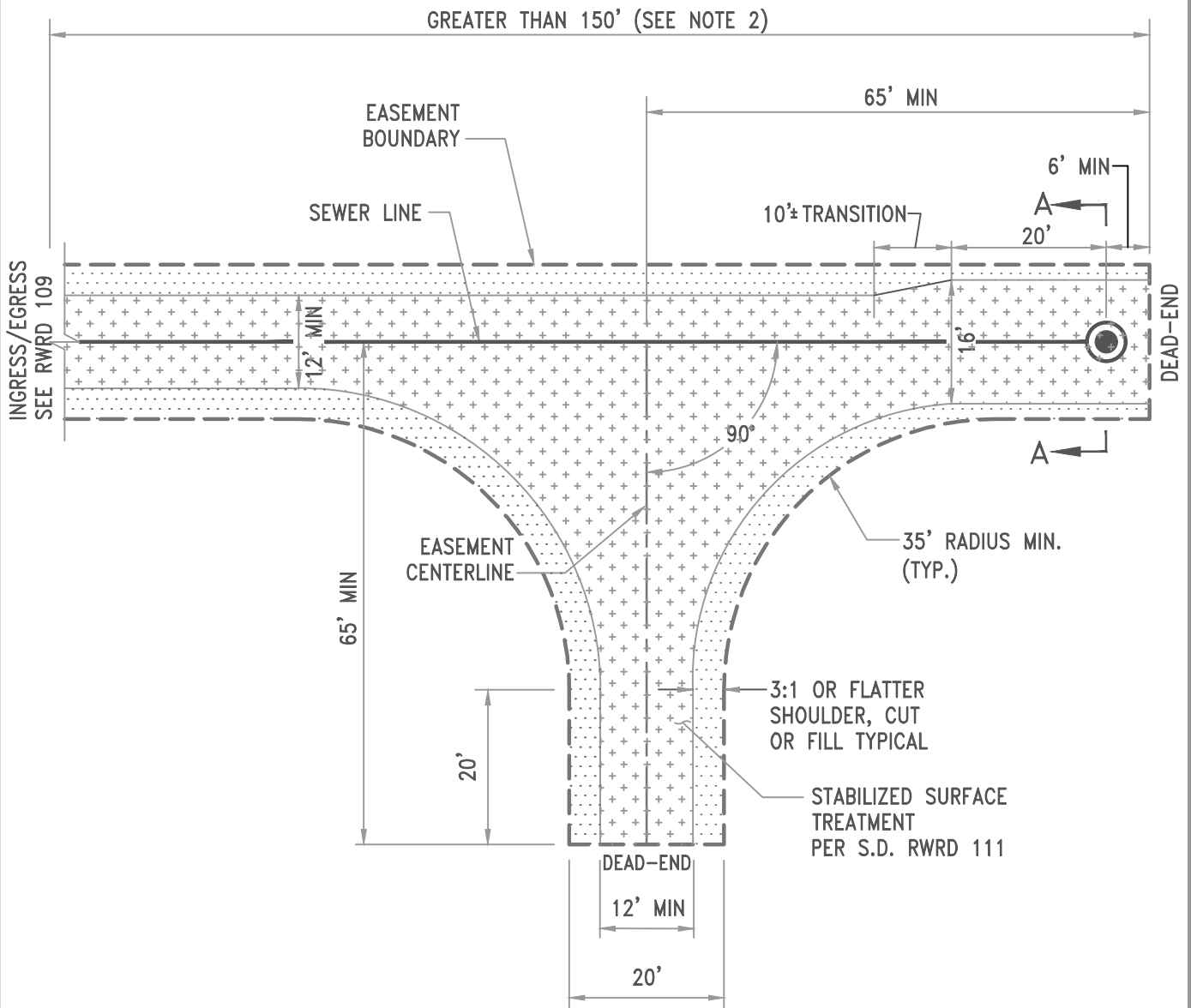

DRAFT

NOTES:

1. SEE S.D. RWRD 111 FOR SECTION A-A.
2. RIGHT ANGLE TURN-AROUNDS REQUIRED FOR DEAD-END SEWER EASEMENTS WITH LENGTHS EXCEEDING 150'. FOR LENGTHS OF 150' OR LESS, A SHORT ACCESS EASEMENT MAY BE PERMITTED. SEE THE DESIGN STANDARDS, SUBSECTION 7.1 FOR MORE INFORMATION.

ISSUED:	STANDARD DETAIL		DETAIL NO.
1/02	RIGHT ANGLE TURN AROUND FOR SEWER EASEMENTS		RWRD 110
REVISED:			SHEET 1 OF 1
02/21			

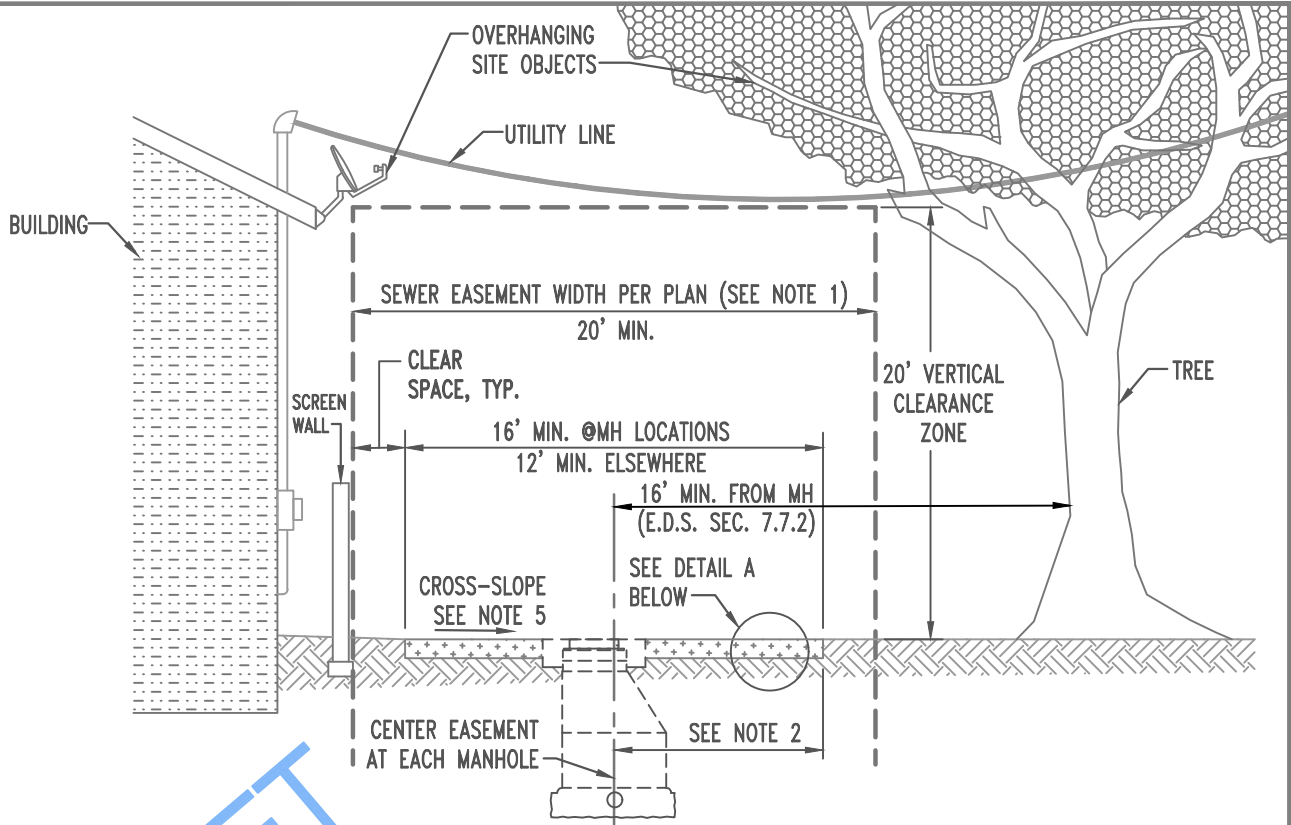

DRAFT

SECTION A-A
(SEE DETAILS S.D. RWRD 109 & 110)
N.T.S.

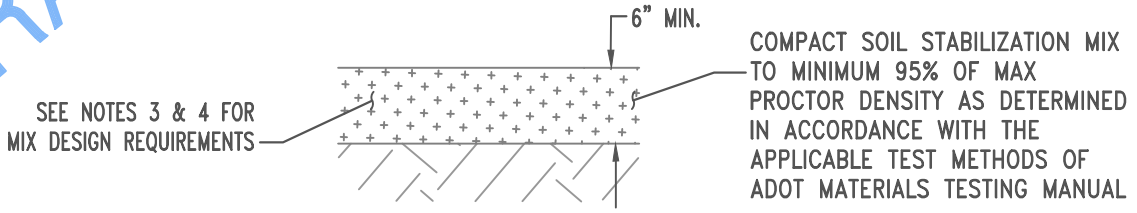

(A) STABILIZED SURFACE TREATMENT
N.T.S.

NOTES:

1. FOR MINIMUM SEWER EASEMENT WIDTHS AND OTHER REQUIREMENTS SEE THE EDS, SUBSECTION 7.1.
2. THE EDGE OF THE STABILIZED SURFACE SHALL BE 6' MINIMUM FROM THE CENTER OF EACH MANHOLE.
3. MIX DESIGN FOR STABILIZED SURFACE TREATMENTS SHALL BE SUBMITTED BY THE CONTRACTOR FOR APPROVAL BY THE FIELD ENGINEER UNLESS PROVIDED ON THE PLANS.
4. MIX DESIGN SHALL BE CERTIFIED BY AN ARIZONA REGISTERED GEOTECHNICAL ENGINEER AND SHALL MEET THE FOLLOWING MINIMUM REQUIREMENTS:
 - BASED ON SITE-SPECIFIC SOILS, USE ONE OF THE FOLLOWING APPROVED STABILIZING AGENTS: HYDRATED LIME SLURRY (HLS), HLS AND FLY ASH, PORTLAND CEMENT, OR AGGREGATE BASE COARSE (ABC).
 - PASS 100% THROUGH THE 3 INCH SIEVE;
 - SHALL NOT CONTAIN DELETERIOUS MATERIALS; AND
 - MINIMUM COMPRESSIVE STRENGTH OF 600-800 PSI.
 SUBMIT ALL TESTING TO THE FIELD ENGINEER. (COMPACTION AND STRESS TESTS)
5. 2% MAXIMUM AT MANHOLE LOCATIONS. 4% MAXIMUM ELSEWHERE.

ISSUED:	STANDARD DETAIL		DETAIL NO.
7/02	SEWER EASEMENT TYPICAL SECTION		RWRD 111
REVISED:			SHEET 1 OF 1
02/21			

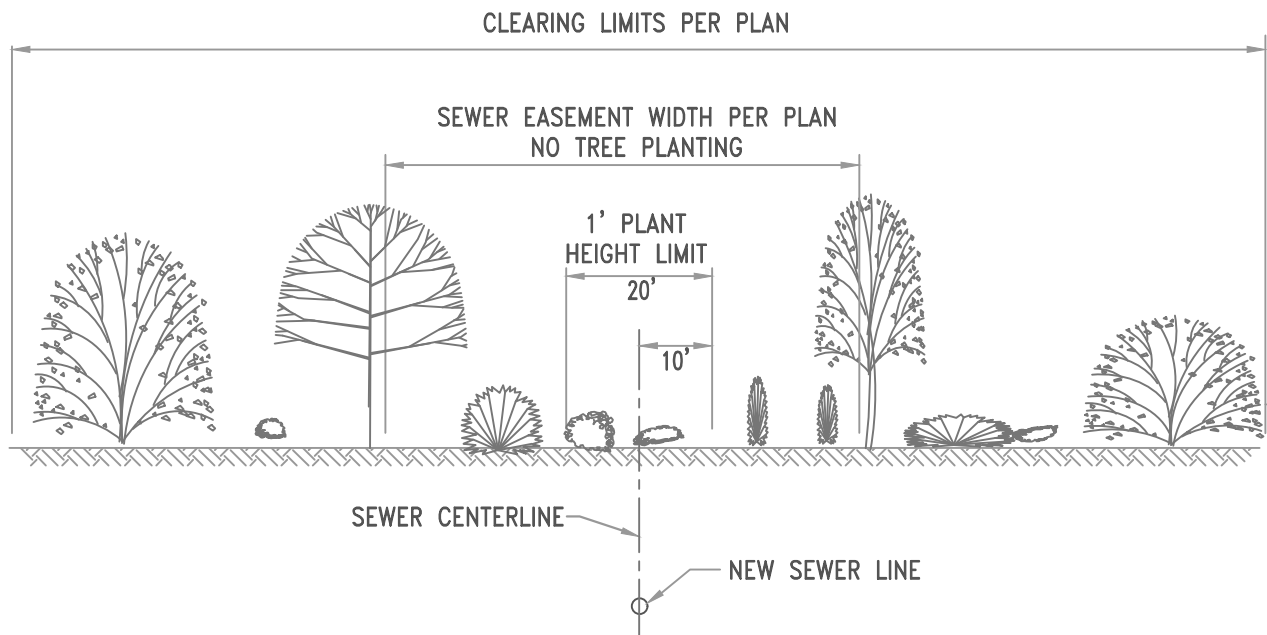

CLEARING AND PLANTING LIMITS
N.T.S.

DRAFT

NOTES:

1. THIS STANDARD DETAIL MAY BE USED BY THE CONTRACTOR IF APPROVED IN THE PLANS AND IN WRITING BY TECHNICAL SERVICES & ENGINEERING.
2. SEE THE ENGINEERING DESIGN STANDARDS, SUBSECTION 7.1 AND 7.7 FOR MORE INFORMATION.

ISSUED:	STANDARD DETAIL SEWER EASEMENTS IN ENVIRONMENTALLY SENSITIVE AREAS		DETAIL NO.
12/12			RWRD 112
REVISED:			SHEET 1 OF 1
02/21			

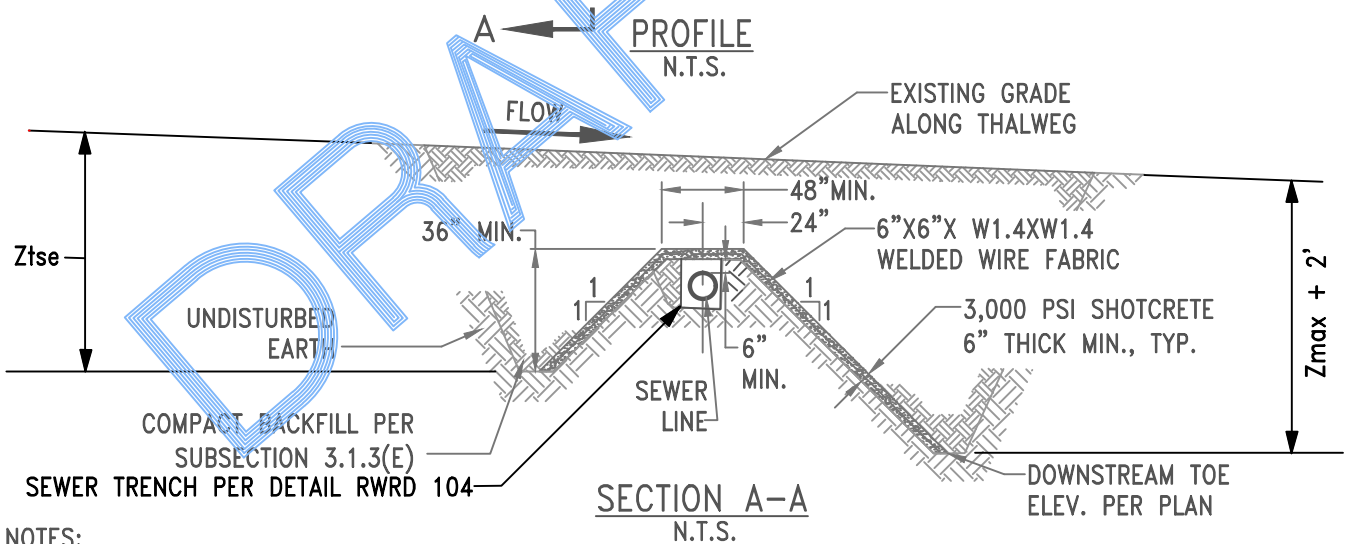
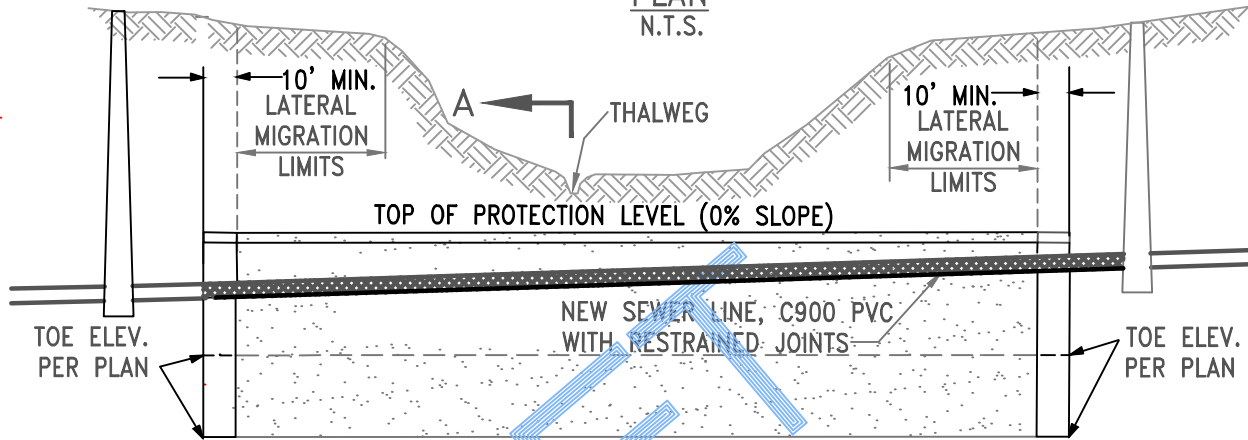
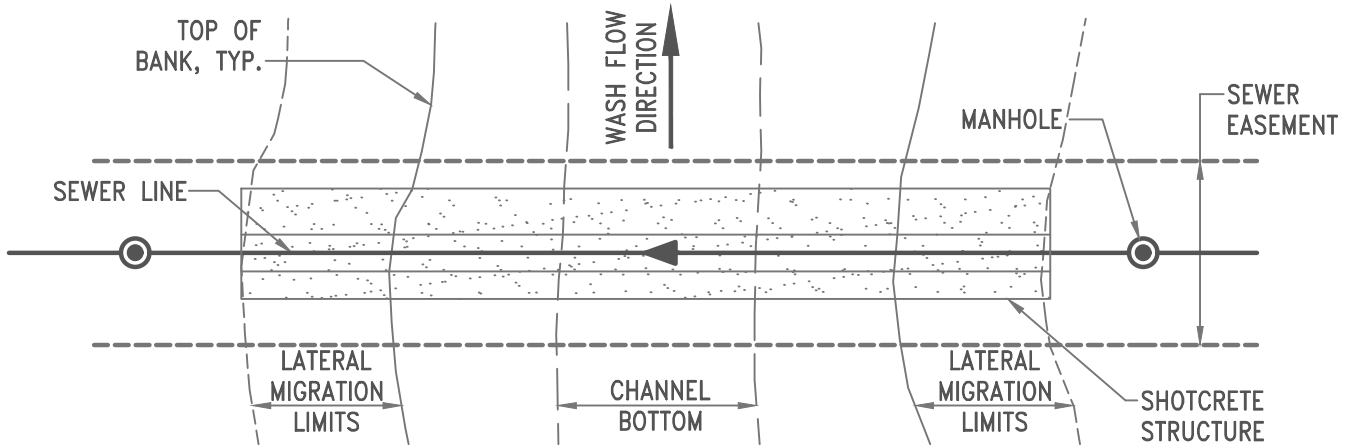

NOTES:

1. THIS DETAIL MAY BE USED IF APPROVED IN THE PLANS AND IN WRITING BY PCRWRD TECHNICAL SERVICES AND ENGINEERING.
2. THIS DETAIL IS INTENDED FOR CASES WHERE IT IS NOT POSSIBLE TO PLACE THE SEWER LINE BELOW THE MAXIMUM PREDICTED SCOUR DEPTH, Z_{max} , AS DEFINED IN APPENDIX A, EDS.
3. THE TOE ELEVATION OF THE DOWNSTREAM AND UPSTREAM GRADE CONTROL STRUCTURES SHALL BE CALCULATED USING APPROPRIATE HYDRAULIC FORMULAS.
4. A DESIGN REPORT SHALL BE INCLUDED WITH THE SEWER PLAN SUBMITTAL (SEC. 5.1.11.A, EDS).

ISSUED:	STANDARD DETAIL		DETAIL NO.
12/12			RWRD 113
REVISED:			SHEET 1 OF 1
02/21	SCOUR PROTECTION FOR SEWER LINES		

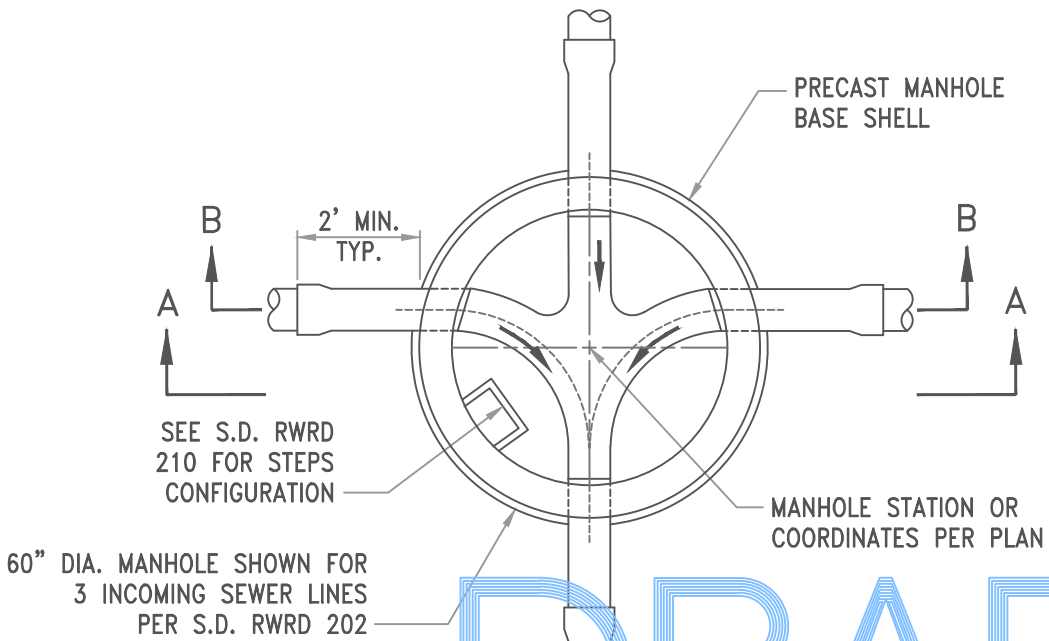

DRAFT

PLAN VIEW
N.T.S.

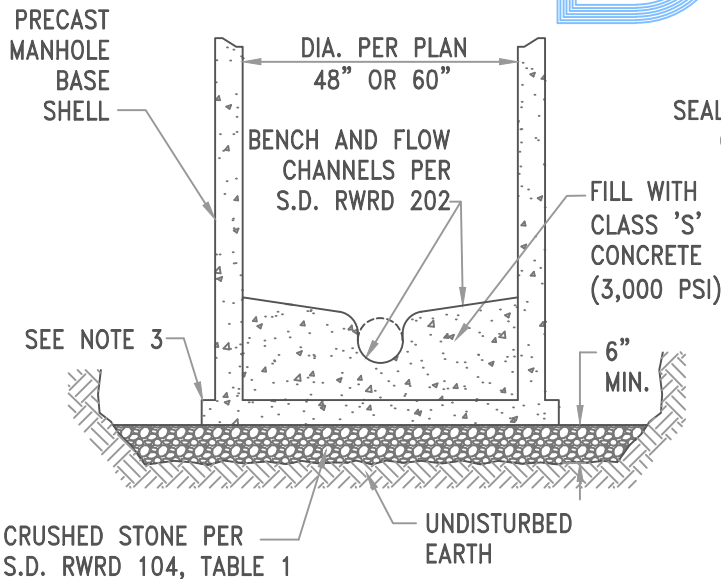

SECTION A-A
N.T.S.

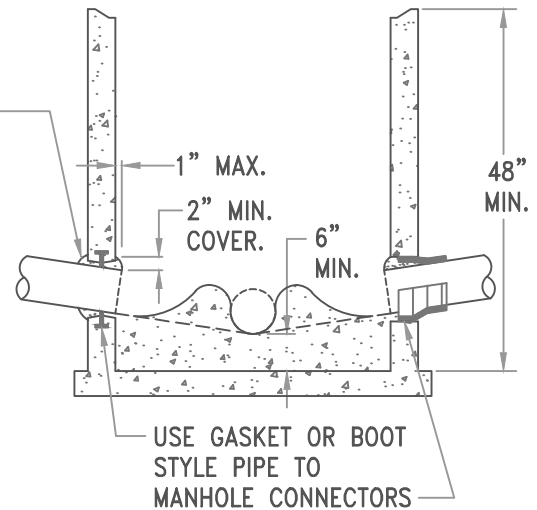

SECTION B-B
N.T.S.

NOTES:

1. CRUSHED STONE SHALL BE LEVELED WITHIN 1/4" OF THE REQUIRED GRADE PRIOR TO PLACEMENT OF THE PRECAST BASE SHELL.
2. PRECAST BASE SHELLS SHALL BE FURNISHED BY THE MANUFACTURER WITH THE REQUIRED PIPE CUT-OUT SIZES AND PRE-INSTALLED PIPE-TO-MANHOLE CONNECTORS. SEE S.D. RWRD 203 FOR BLOCK-OUT REQUIREMENTS.
3. MINIMUM TOE DIMENSIONS PER PLAN FOR MANHOLES REQUIRING REINFORCED JOINTS PER S.D. RWRD 209.
4. SEE SUBSECTION 3.3.3(B)(iii) FOR MORE INFORMATION.

ISSUED:	STANDARD DETAIL		DETAIL NO.
12/12	PRECAST		RWRD 200
REVISED:	MANHOLE BASE		SHEET 1 OF 1
10/15			

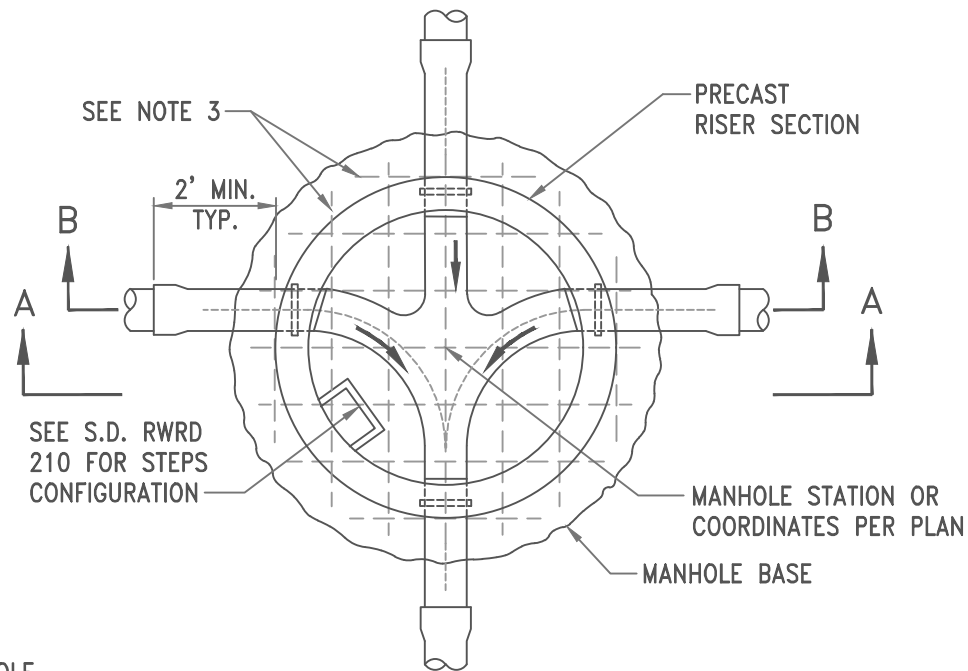

PLAN VIEW
N.T.S.

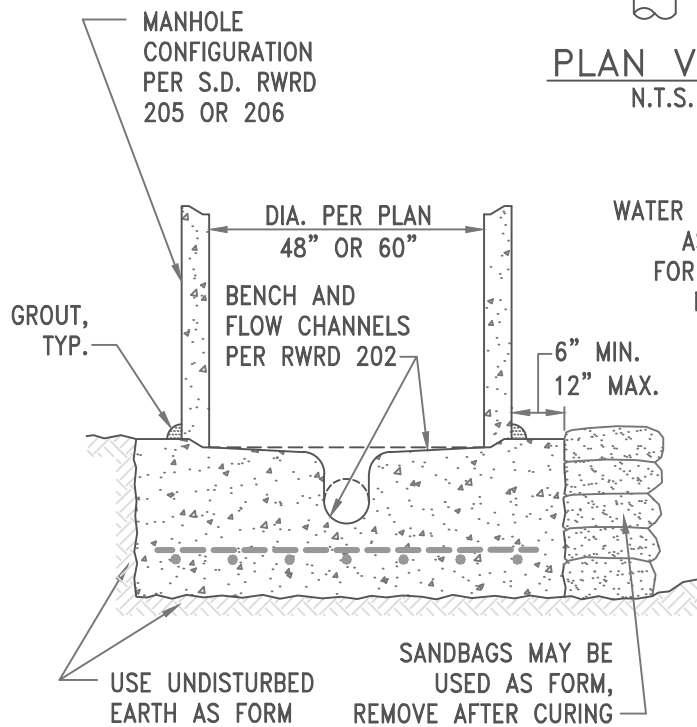

SECTION A-A
N.T.S.

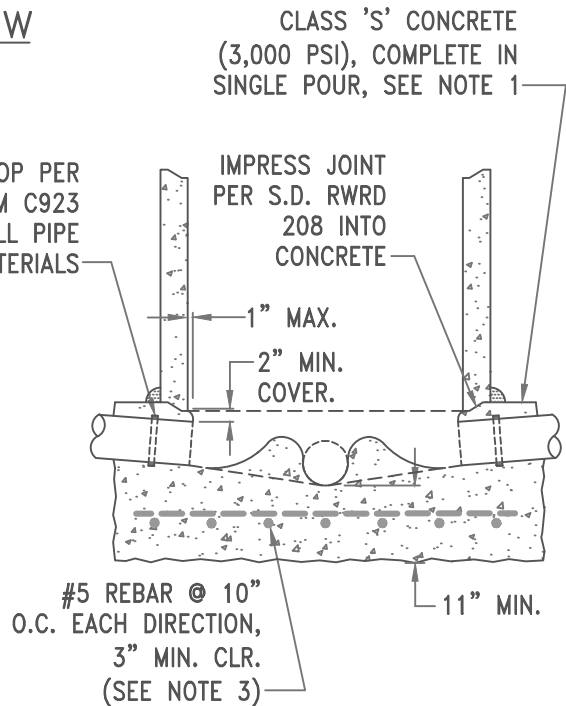

SECTION B-B
N.T.S.

NOTES:

1. FOR NEXT DAY INSTALLATIONS OF PRECAST SECTIONS ON A NEWLY-POURED CONCRETE BASE, USE HIGH-EARLY, CLASS 'S' CONCRETE HAVING A MIN. COMPRESSIVE STRENGTH OF 2,000 PSI AT 24 HOURS AS DEMONSTRATED BY LABORATORY TESTING OF SAMPLE CYLINDERS.
2. SEE SUBSECTION 3.3.3(B)(i) FOR MORE INFORMATION.
3. REINFORCEMENT REQUIRED FOR MANHOLE DEPTHS (RIM TO INVERT) OF 20' OR GREATER.

DRAFT

ISSUED:	STANDARD DETAIL		DETAIL NO.
8/92	CAST-IN-PLACE MANHOLE BASE		RWRD 201
REVISED:			SHEET 1 OF 1
10/15			

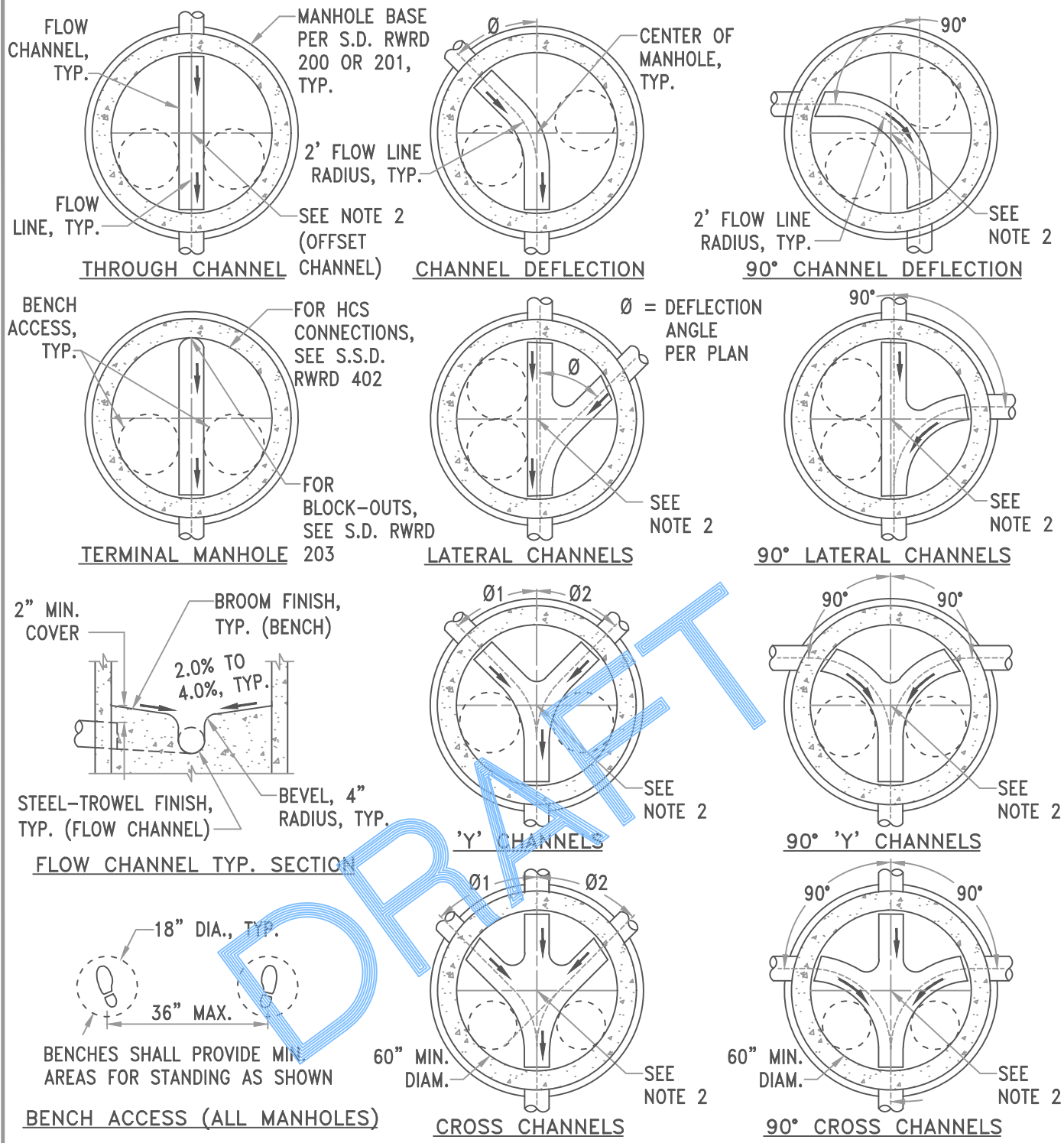

NOTES:

1. FLOW CHANNEL CONFIGURATIONS PROVIDED IN THIS DETAIL SHALL ONLY APPLY TO 48" AND 60" DIAMETER MANHOLES. FOR LARGER MANHOLES REFER TO THE PLANS FOR REQUIRED FLOW CHANNEL CONFIGURATION.
2. SHIFT CENTER OF MANHOLE AS NEEDED FOR BENCH ACCESS AND CCTV CAMERA ACCESS. FLOW CHANNELS SHALL BE FORMED TO PROVIDE A SMOOTH TRANSITION OF FLOW FROM THE INCOMING PIPES TO THE OUTGOING PIPE.
3. FOR THE MINIMUM MANHOLE DIAMETER REQUIREMENTS, SEE THE DESIGN STANDARDS, SUBSECTION 5.2.7.

ISSUED:	STANDARD DETAIL MANHOLE FLOW CHANNELS	 PIMA COUNTY WASTEWATER RECLAMATION	DETAIL NO.
12/12			RWRD 202
REVISED:			SHEET 1 OF 1
10/15			

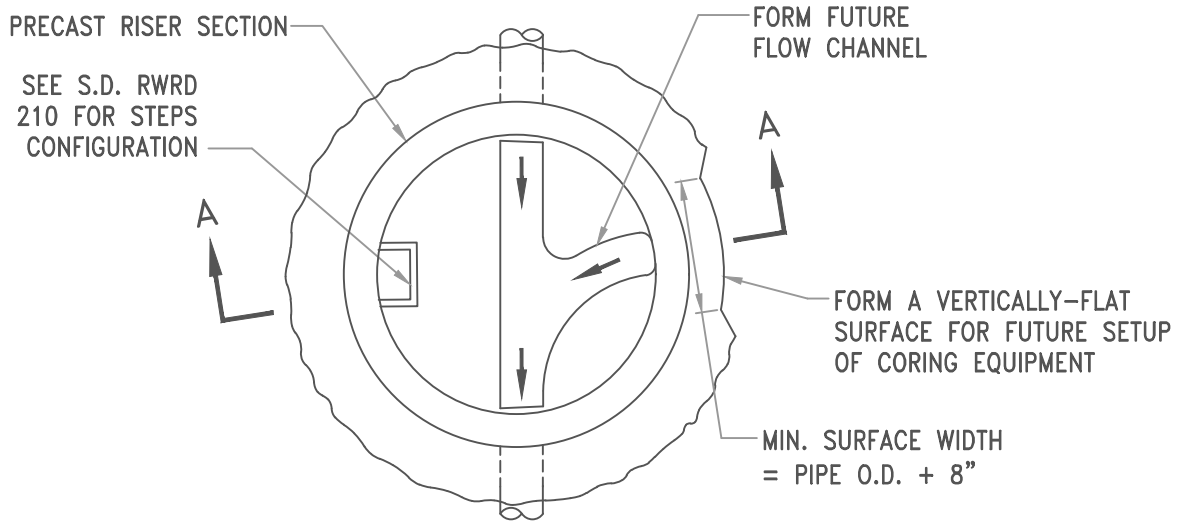

PLAN VIEW
N.T.S.

MANHOLE CONFIGURATION
PER S.D. RWRD 205 OR
206

CAST-IN-PLACE BASE
PER S.D. RWRD 201

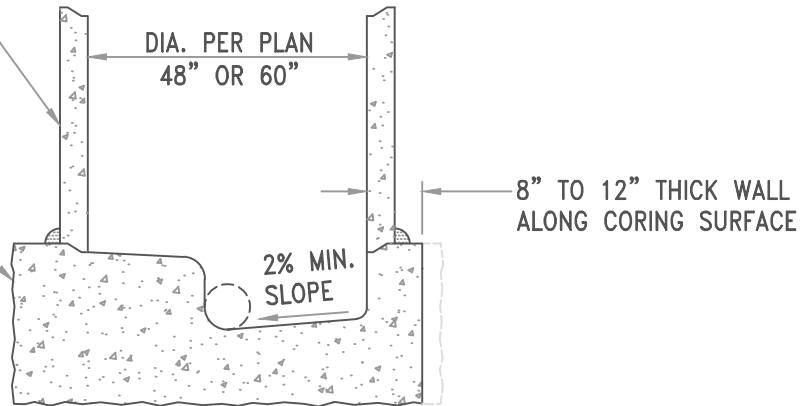

SECTION A-A
N.T.S.

DRAFT

NOTES:

1. THIS DETAIL APPLIES TO 4' AND 5' DIAMETER MANHOLES. FOR LARGER DIAMETER MANHOLES, REFER TO PLAN FOR BLOCK-OUT REQUIREMENTS.
2. FOR PRECAST BASES, MANUFACTURER SHALL FURNISH BLOCK-OUT CAPS FOR THE PRE-INSTALLED MANHOLE CONNECTOR IN LIEU OF USING 2" MORTAR COVER.

ISSUED:	STANDARD DETAIL		DETAIL NO.
8/92			RWRD 203
REVISED:	BLOCK-OUTS		SHEET 1 OF 1
12/12			

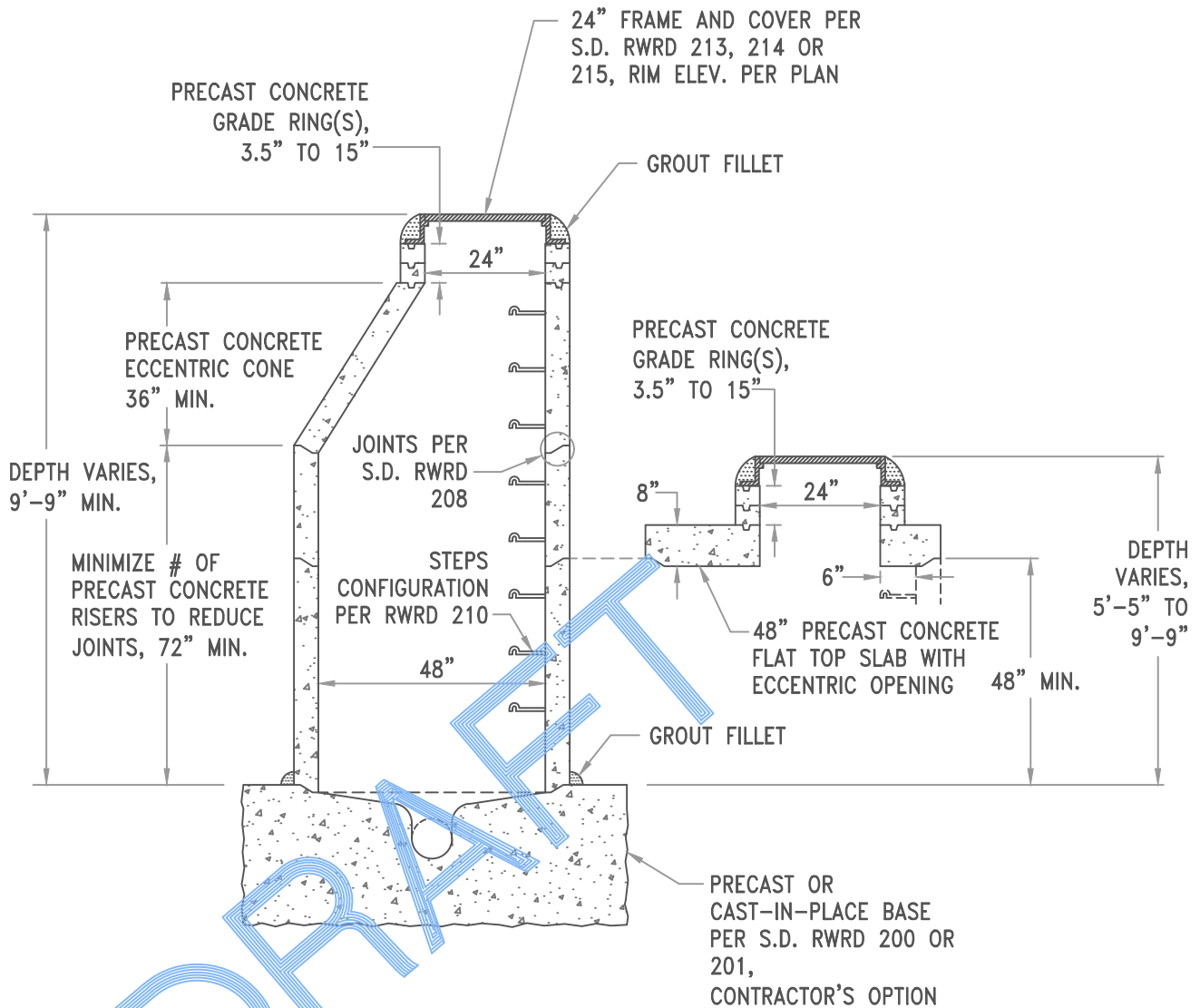

NOTES:

1. PRECAST CONCRETE MANHOLE SECTIONS SHALL CONFORM TO ASTM C478 AND AASHTO M199.
2. FOR 4' DIAMETER MANHOLE DEPTHS LESS THAN 5'-5" (SHALLOW MANHOLES), SEE S.D. RWRD 207; TYPE I.
3. SEE SUBSECTIONS 3.3.2(E) AND 3.3.3 FOR MORE INFORMATION.

ISSUED:	STANDARD DETAIL 4' DIAMETER MANHOLE CONFIGURATIONS	 PIMA COUNTY WASTEWATER RECLAMATION	DETAIL NO.
8/92			RWRD 205
REVISED:			SHEET 1 OF 1
02/21			

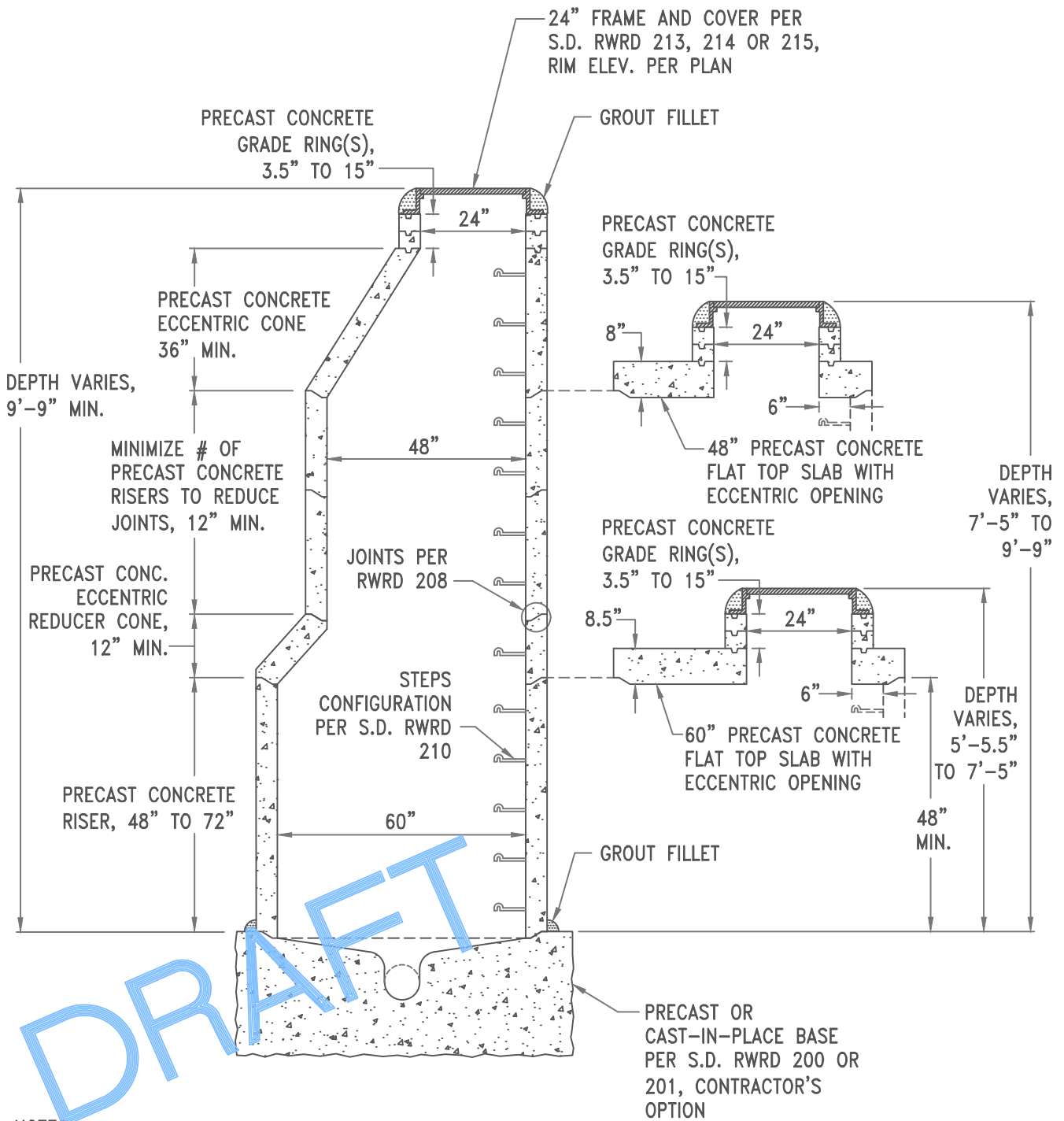

NOTES:

1. PRECAST CONCRETE MANHOLE SECTIONS SHALL CONFORM TO ASTM C478 AND AASHTO M199.
2. FOR 5' DIAMETER MANHOLE DEPTHS LESS THAN 5'-5.5" (SHALLOW MANHOLES), SEE S.D. RWRD 207; TYPE II.
3. SEE SUBSECTIONS 3.3.2(E) AND 3.3.3 FOR MORE INFORMATION.

ISSUED:	STANDARD DETAIL 5' DIAMETER MANHOLE CONFIGURATIONS	 PIMA COUNTY WASTEWATER RECLAMATION	DETAIL NO.
8/92			RWRD 206
REVISED:			SHEET 1 OF 1
02/21			

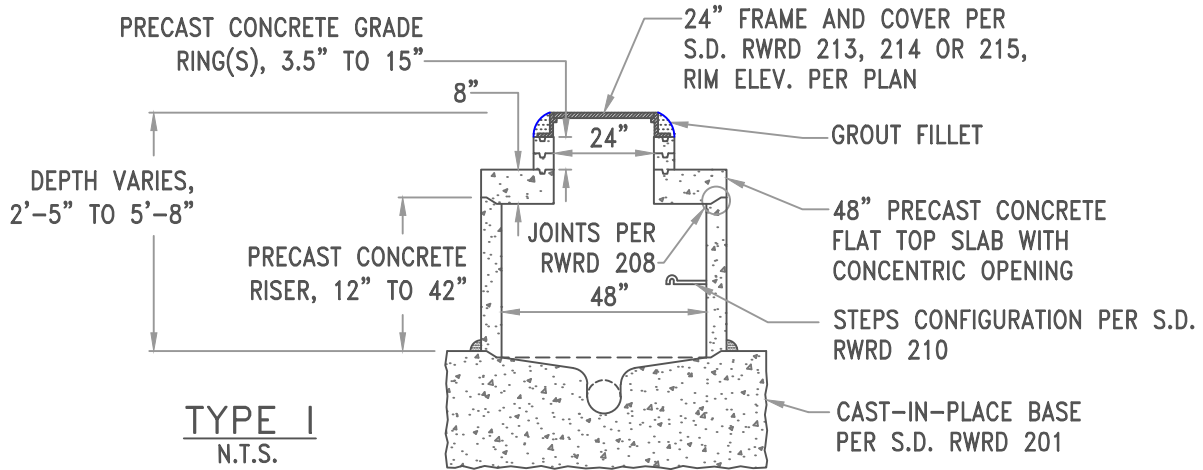

TYPE I
N.T.S.

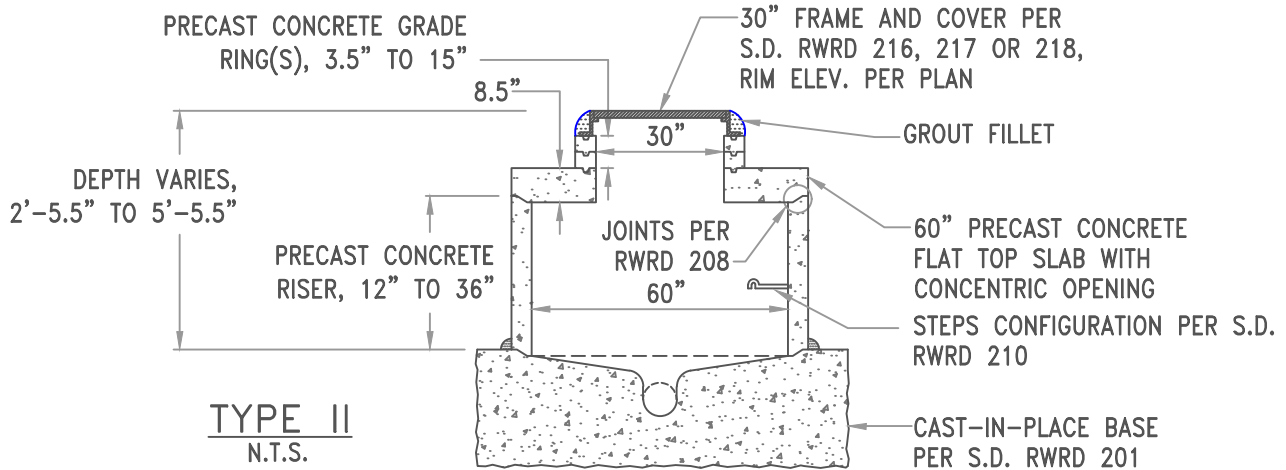

TYPE II
N.T.S.

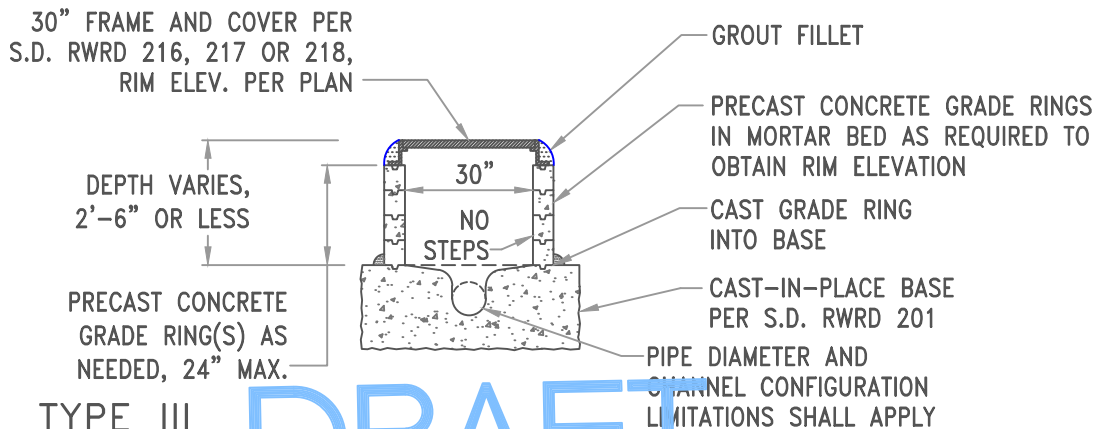

TYPE III
N.T.S.

DRAFT

NOTES:

1. THIS STANDARD DETAIL MAY BE USED BY THE CONTRACTOR IF APPROVED IN THE PLANS OR IN WRITING.
2. PRECAST CONCRETE MANHOLE SECTIONS SHALL CONFORM TO ASTM C478 AND AASHTO M199.
3. SEE SUBSECTIONS 3.3.2(E) AND 3.3.3 FOR MORE INFORMATION.

ISSUED:	STANDARD DETAIL		DETAIL NO.	
8/92			RWRD 207	
REVISED:			SHALLOW MANHOLES	SHEET 1 OF 1
02/21				

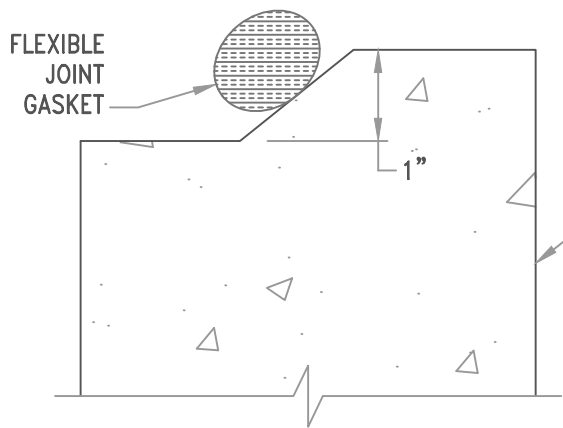
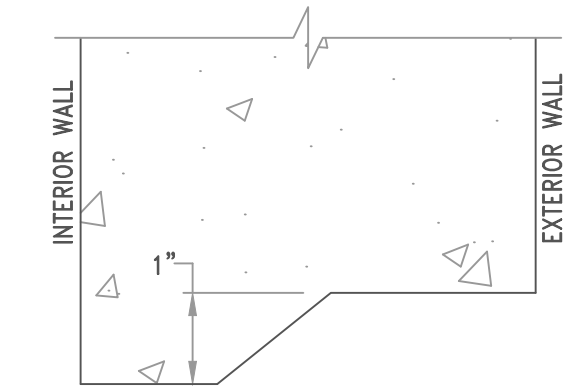

"BELL-UP" JOINT (OPEN)
N.T.S.

REMOVE EXCESS
JOINT GASKET
(BOTH SIDES)
AND APPLY
NON-SHRINK
GROUT
(INTERIOR)

PRECAST MANHOLE
SECTIONS PER S.D.
RWRD 205 OR
206, TYP.

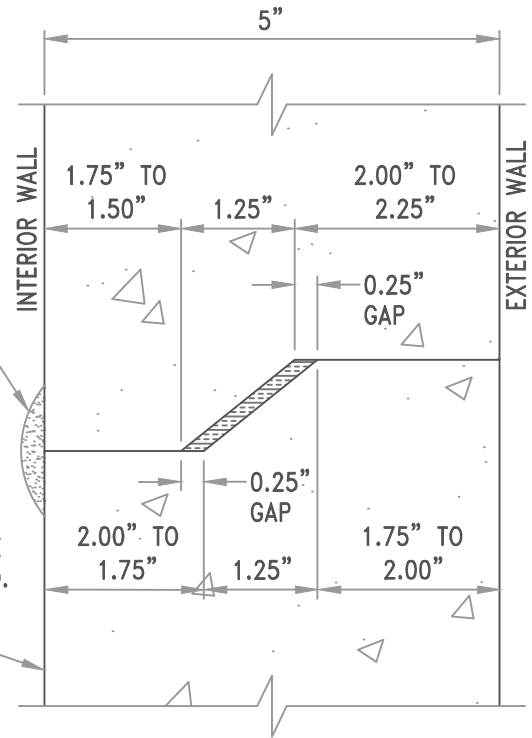

"BELL-UP" JOINT (CLOSED)
N.T.S.

DRAFT

NOTES:

1. THIS DETAIL APPLIES TO 4' AND 5' DIAMETER PRECAST MANHOLE SECTIONS. SHOP DRAWINGS AND JOINT DETAILS FOR LARGER MANHOLE DIAMETERS SHALL BE SUBMITTED TO THE FIELD ENGINEER FOR REVIEW AND APPROVAL.
2. THE MIXING OF JOINTS WITHIN A MANHOLE IS NOT PERMITTED WITHOUT APPROVAL BY THE FIELD ENGINEER.
3. SEE SUBSECTION 3.3.3(B)(iii) FOR MORE INFORMATION.

ISSUED:	STANDARD DETAIL		DETAIL NO.
8/92 (WWM-226)	MANHOLE JOINTS		RWRD 208
REVISED:		SHEET 1 OF 1	
12/12			

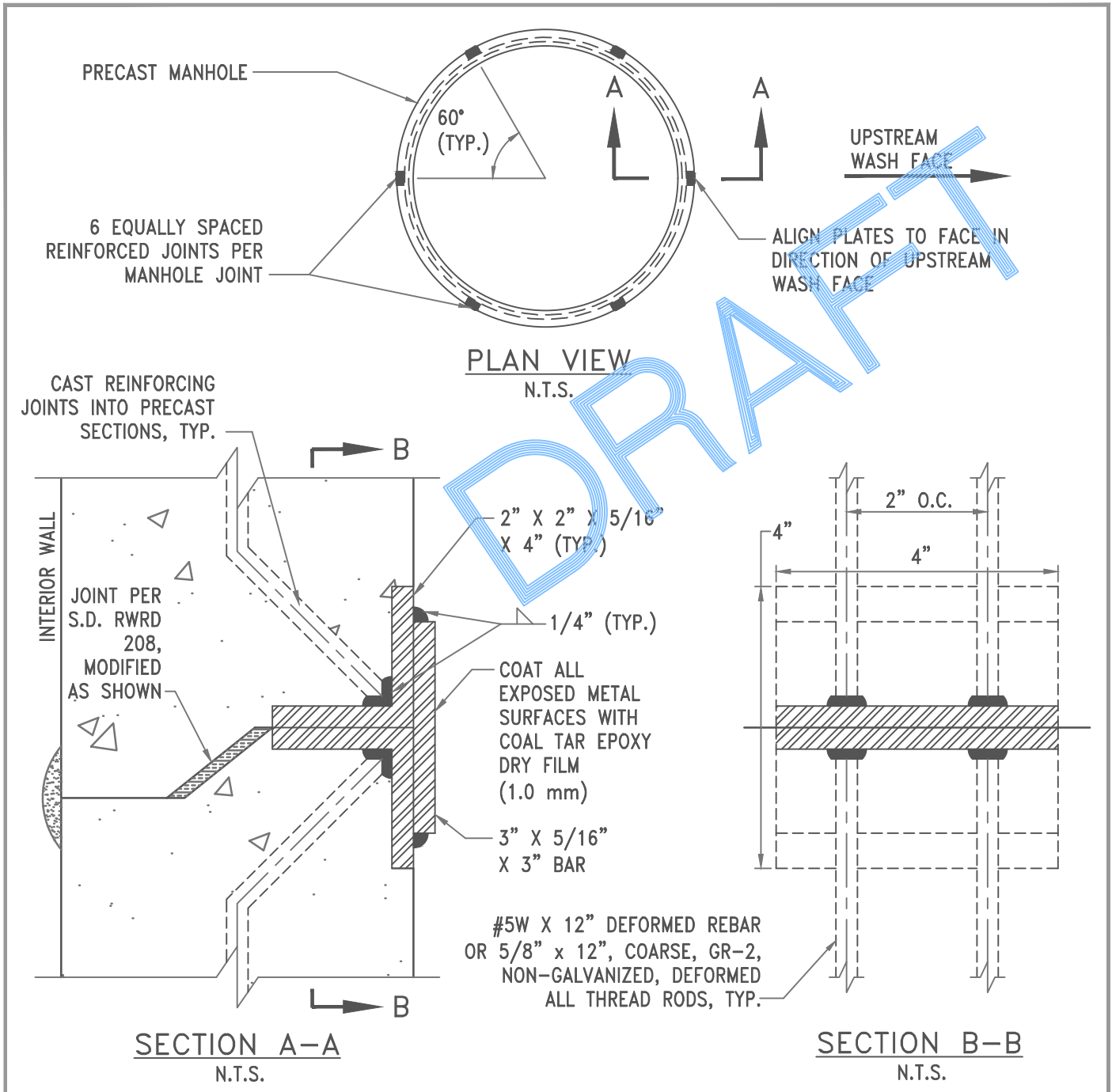

NOTES:

1. THIS STANDARD DETAIL MAY BE USED BY THE CONTRACTOR IF APPROVED IN THE PLANS OR IN WRITING AND IS TYPICALLY FOR USE WITH MANHOLES LOCATED IN WASH CROSSINGS.
2. THIS DETAIL APPLIES TO 4' AND 5' DIAMETER MANHOLES WITH DEPTHS OF 12' OR GREATER (RIM TO INVERT) AND 3 OR LESS PRECAST SECTIONS. ALL OTHER CASES, SEE PLANS FOR MODIFIED REINFORCED MANHOLE JOINTS.
3. FIELD WELD THE REINFORCED JOINTS AS SHOWN AND IMMEDIATELY QUENCH WITH AN APPROVED OIL QUENCHING MEDIUM AFTER EACH WELD IS COMPLETED.
4. SEE SUBSECTION 3.3.3(B)(ix) FOR MORE INFORMATION.

ISSUED:	STANDARD DETAIL REINFORCED MANHOLE JOINTS	 PIMA COUNTY WASTEWATER RECLAMATION	DETAIL NO.
8/92 (WWM-223)			RWRD 209
REVISED:			SHEET 1 OF 1
02/21			

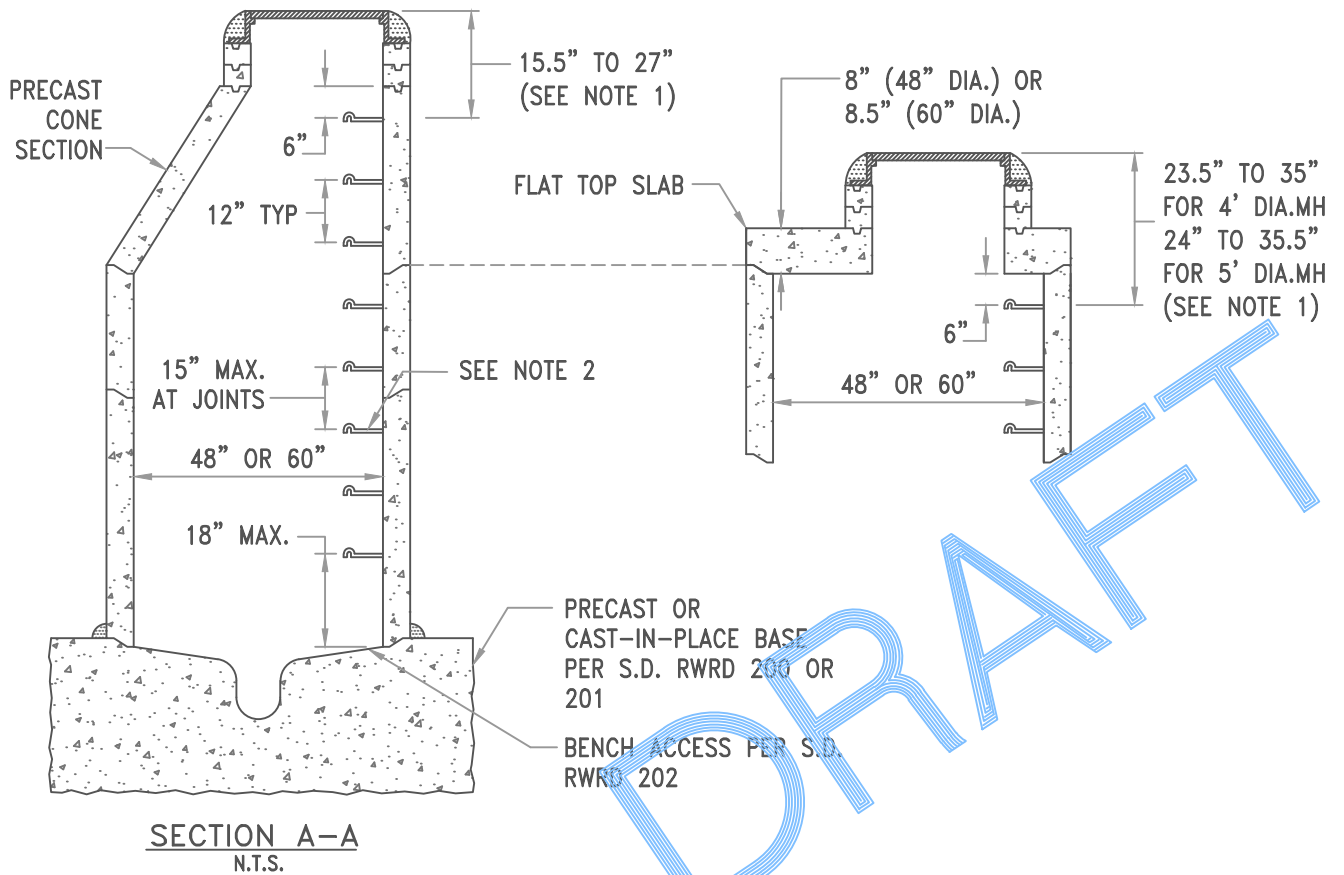
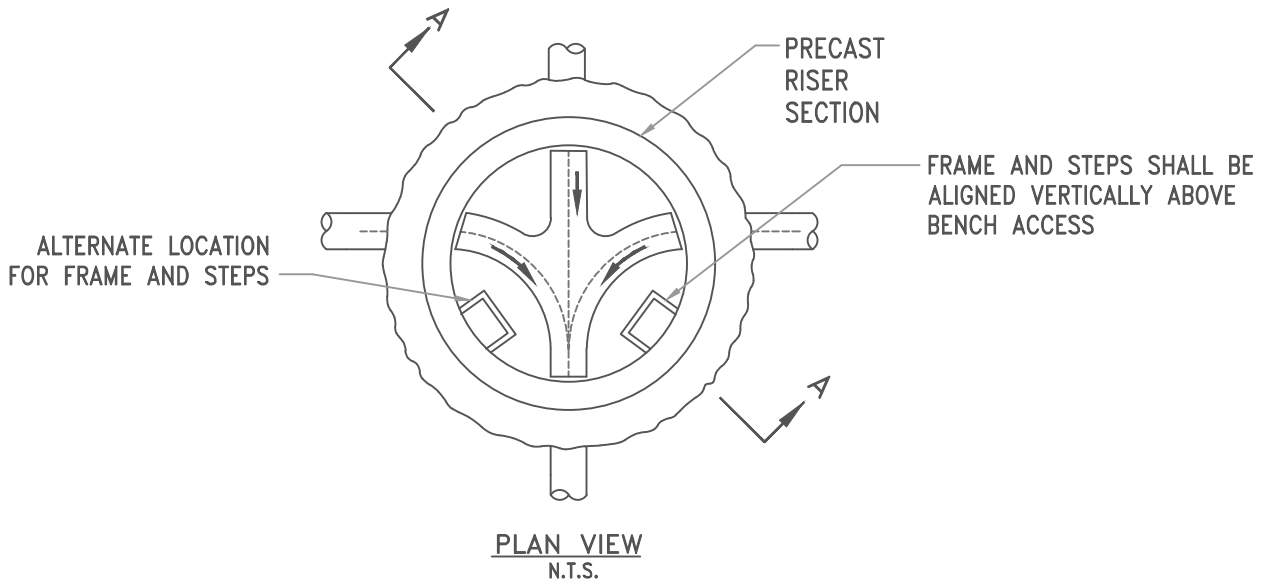

NOTES:

1. THIS DETAIL APPLIES TO NEW MANHOLE CONSTRUCTION, FOR GRADE ADJUSTMENTS TO EXISTING MANHOLES, SEE S.D. RWRD 304 AND 305 FOR ALLOWABLE DEPTHS FROM RIM TO FIRST MANHOLE STEP.
2. SEE SUBSECTION 3.3.2(G) AND 3.3.3(B)(iv) FOR MORE INFORMATION.

ISSUED:	STANDARD DETAIL MANHOLE STEPS CONFIGURATION	 PIMA COUNTY WASTEWATER RECLAMATION	DETAIL NO.
12/12			RWRD 210
REVISED:			SHEET 1 OF 1
02/21			

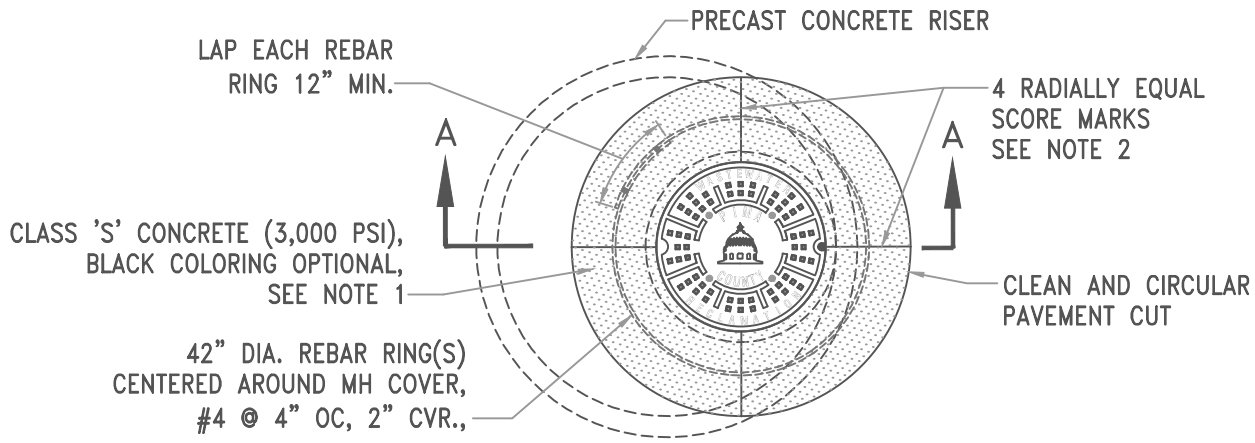

PLAN VIEW
N.T.S.

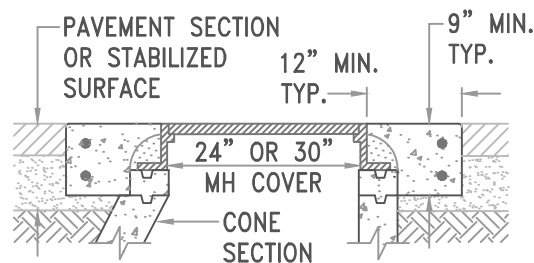

SECTION A-A FOR CONE-TOP
N.T.S.

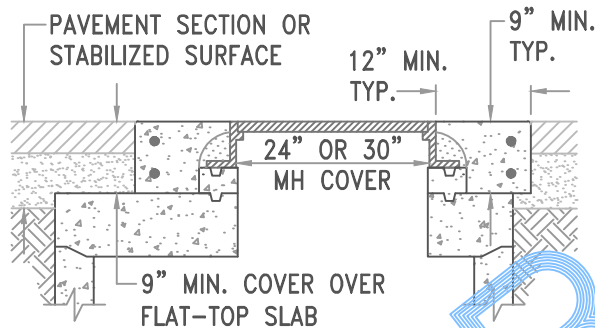

SECTION A-A FOR FLAT-TOP
N.T.S.

NOTES:

1. FOR MANHOLES LOCATED WITHIN RIGHT-OF-WAY, OPTIONS SHOWN (E.G. COLORING AGENTS AND CONCEALED/ REVEALED COLLARS) WILL BE DICTATED BY THE TRANSPORTATION AGENCY HAVING JURISDICTION.
2. FINISH ALL CONCRETE EDGES AND SCORE MARKS WITH A HAND TROWEL HAVING A 1/4" RADIUS. EXPOSED SURFACES SHALL HAVE A MEDIUM BROOM FINISH.
3. MINIMUM COLLAR THICKNESS MAY BE REDUCED TO 6" FOR SLAB COVER DEPTHS OF 11" OR LESS.

ISSUED:	STANDARD DETAIL CONCRETE COLLAR FOR PAVED AREAS	 PIMA COUNTY WASTEWATER RECLAMATION	DETAIL NO.
12/12			RWRD 211
REVISED:			SHEET 1 OF 1
02/21			

CLASS 'S' CONCRETE
(3,000 PSI),
SEE NOTE 1

PRECAST
CONCRETE
RISER

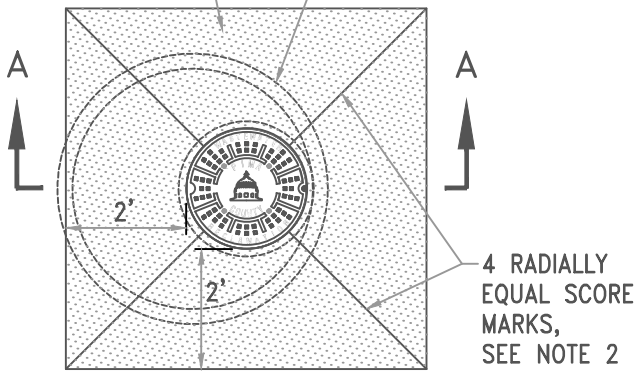

PLAN VIEW
SQUARE COLLAR
N.T.S.

CLASS 'S' CONCRETE
(3,000 PSI),
SEE NOTE 1

PRECAST
CONCRETE
RISER

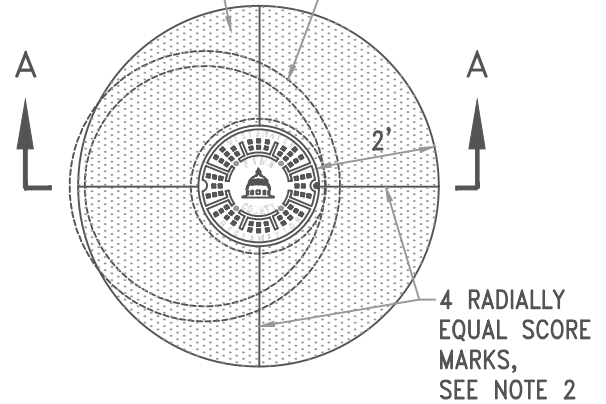

PLAN VIEW
ROUND COLLAR
N.T.S.

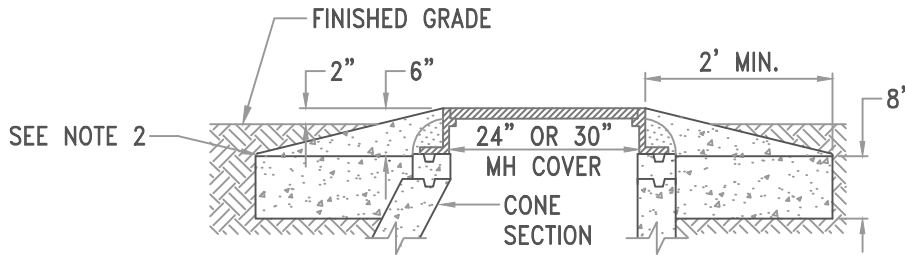

SECTION A-A (FOR CONE SECTIONS)
N.T.S.

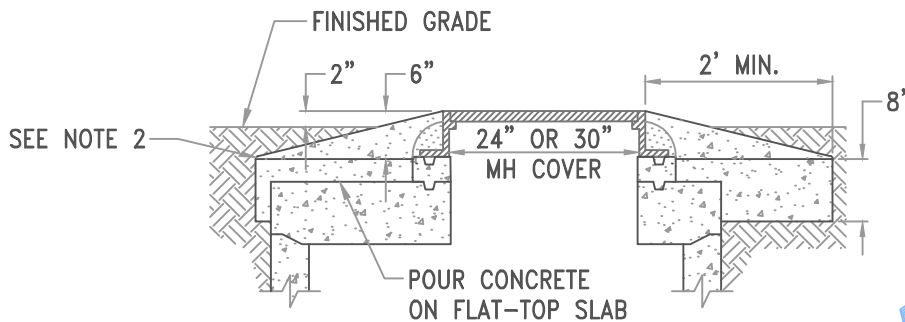

SECTION A-A (FOR FLAT-TOP SLABS)
N.T.S.

NOTES:

1. SQUARE OR ROUND TYPE COLLARS SHOWN ARE CONTRACTOR'S OPTION. ALL COLLARS SHALL BE FORMED.
2. FINISH ALL CONCRETE EDGES AND SCORE MARKS WITH A HAND TROWEL HAVING A 1/4" RADIUS. EXPOSED CONCRETE SURFACES SHALL HAVE A MEDIUM BROOM FINISH.

DRAFT

ISSUED:	STANDARD DETAIL		DETAIL NO.
9/93	CONCRETE COLLAR		RWRD 212
REVISED:	FOR UNPAVED AREAS		SHEET 1 OF 1
02/21			

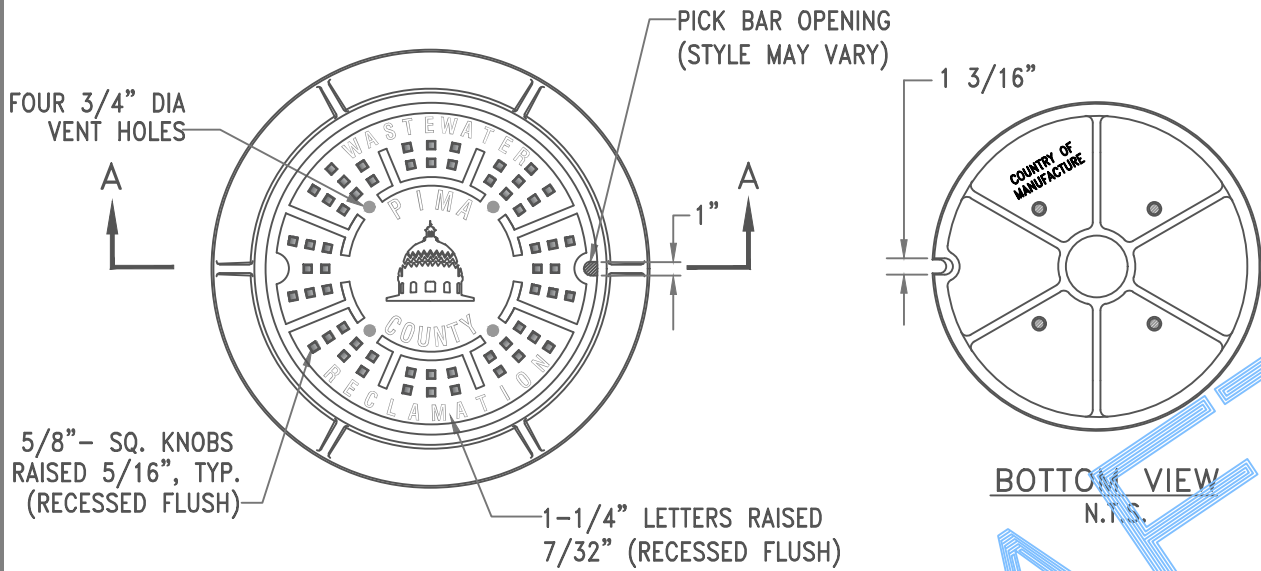

FRAME AND COVER – PLAN VIEW
N.T.S.

BOTTOM VIEW
N.T.S.

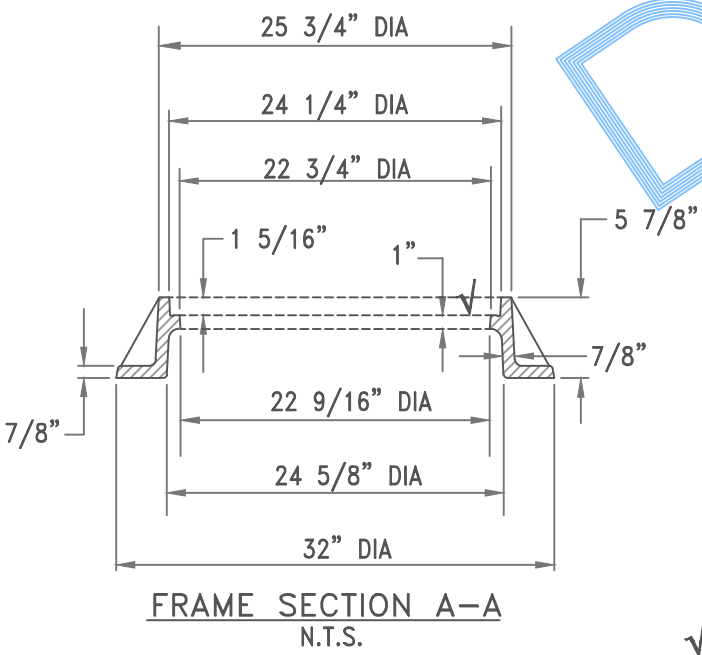

FRAME SECTION A-A
N.T.S.

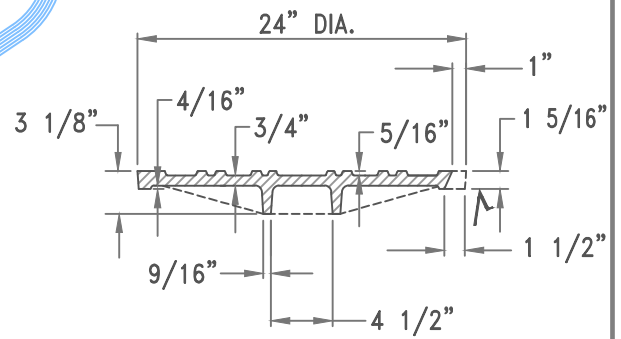

COVER SECTION
N.T.S.

√ DENOTES MACHINED SURFACE

NOTES:

1. COVER STYLE MAY SLIGHTLY VARY WITH APPROVAL BY THE FIELD ENGINEER.
2. FRAME WEIGHT 180 LBS. (APPROX.) AND COVER WEIGHT 130 LBS. (APPROX.)
3. REFER TO SECTION 3.3.2(H) FOR MORE INFORMATION.

ISSUED:	STANDARD DETAIL		DETAIL NO.
8/92	24" FRAME AND COVER		RWRD 213
REVISED:			SHEET 1 OF 1
02/21			

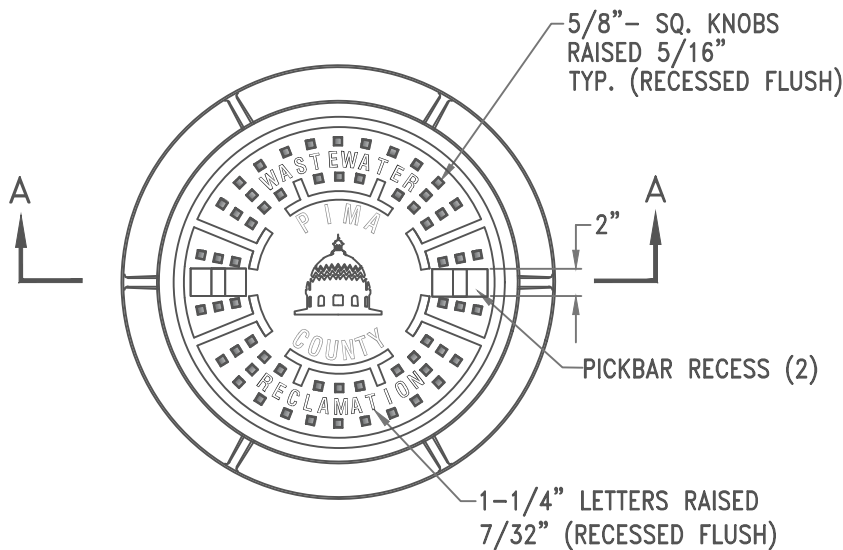

FRAME AND COVER – PLAN VIEW
N.T.S.

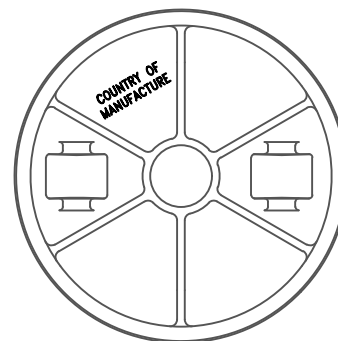

BOTTOM VIEW
N.T.S.

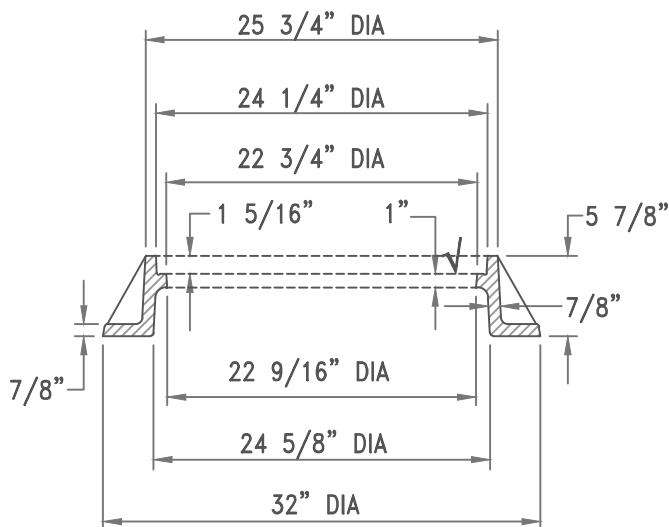

FRAME SECTION A-A
N.T.S.

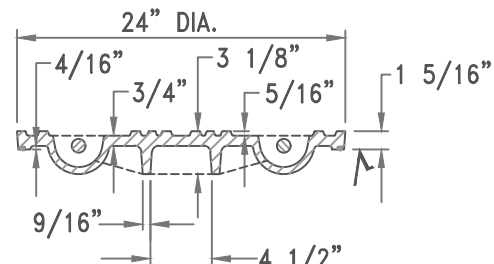

COVER SECTION
N.T.S.

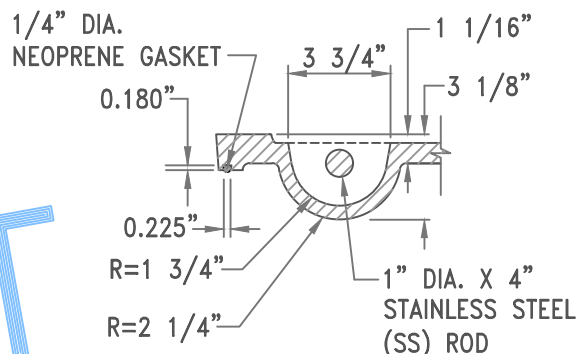

PICKBAR RECESS DETAIL
N.T.S.

DRAFT

✓ DENOTES MACHINED SURFACE

NOTES:

1. COVER STYLE MAY SLIGHTLY VARY WITH APPROVAL BY THE FIELD ENGINEER.
2. THE COVER SHALL HAVE PICKBAR RECESSES AS DETAILED HEREIN. VENT HOLES SHALL NOT BE PROVIDED.
3. FRAME WEIGHT 180 LBS. (APPROX.) AND COVER WEIGHT 130 LBS. (APPROX.)
4. REFER TO SECTION 3.3.2(H) FOR MORE INFORMATION.

ISSUED:	STANDARD DETAIL		DETAIL NO.
8/92 (WWM-213.2)	24\"/> 		

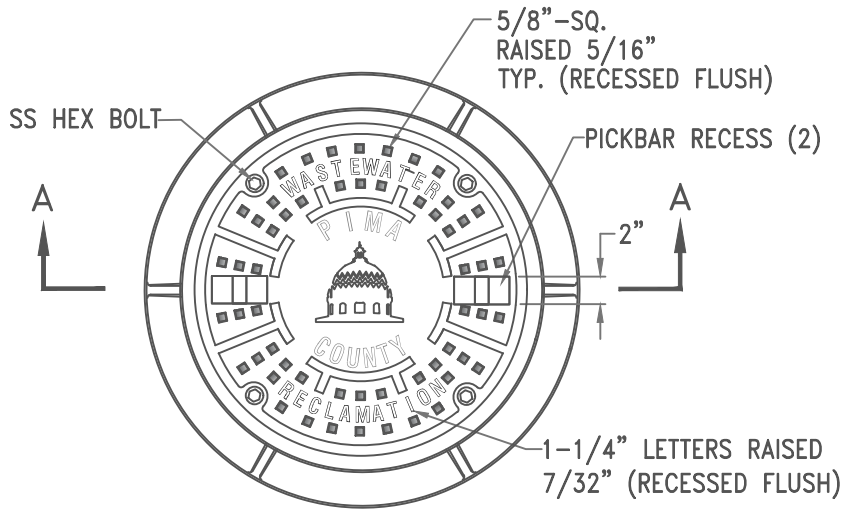

FRAME AND COVER - PLAN VIEW
N.T.S.

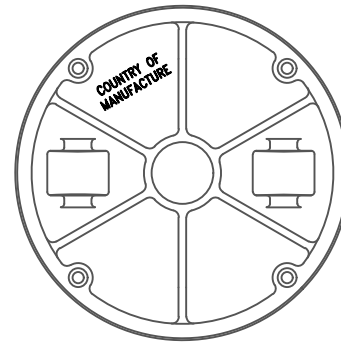

BOTTOM VIEW
N.T.S.

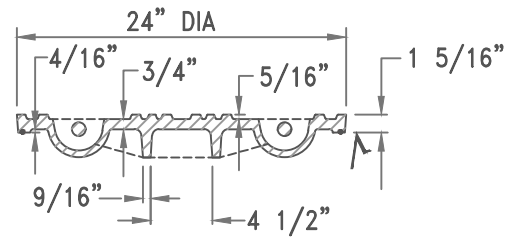

COVER SECTION
N.T.S.

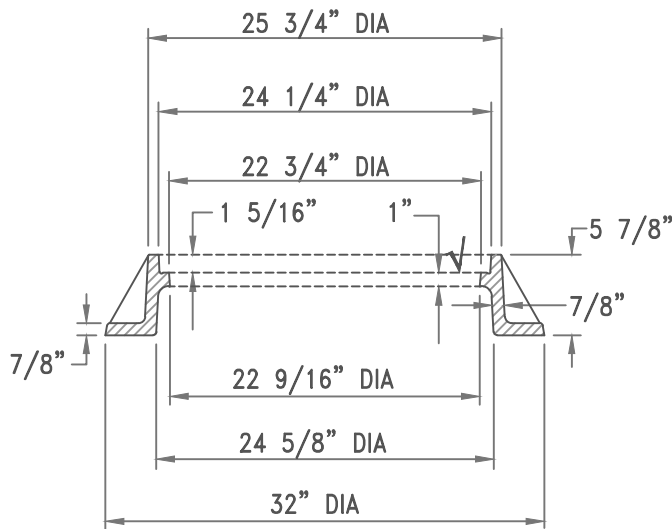

FRAME SECTION A-A
N.T.S.

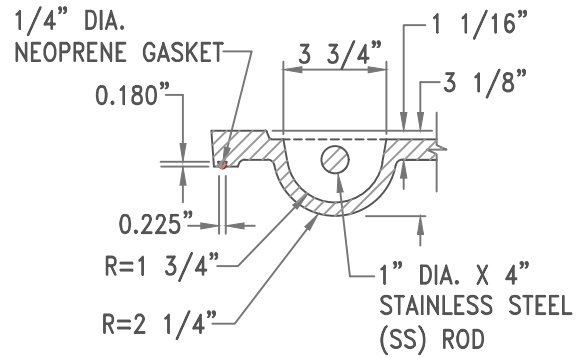

PICKBAR RECESS DETAIL
N.T.S.

DRAFT

√ DENOTES MACHINED SURFACE

NOTES:

1. COVER STYLE MAY SLIGHTLY VARY WITH APPROVAL BY THE FIELD ENGINEER.
2. THE COVER SHALL HAVE PICKBAR RECESSES. VENT HOLES SHALL NOT BE PROVIDED.
3. FRAME WEIGHT 180 LBS. (APPROX.) AND COVER WEIGHT 130 LBS. (APPROX.)
4. REFER TO SECTION 3.3.2(H) FOR MORE INFORMATION.

- SS HEX BOLT (1/2"-13 UNC x 1 3/4")
- SS WASHER (1/2" I.D. x 1 1/4" O.D.)
- RUBBER WASHER (1/2" FLAT)

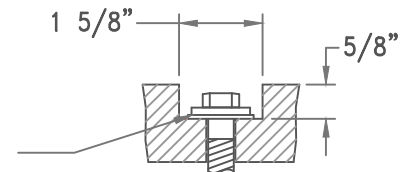

BOLT HOLE DETAIL
N.T.S.

ISSUED:	STANDARD DETAIL 24" BOLTED WATERTIGHT FRAME AND COVER		DETAIL NO.
8/92 (WWM-213.3)			RWRD 215
REVISED:			SHEET 1 OF 1
02/21			

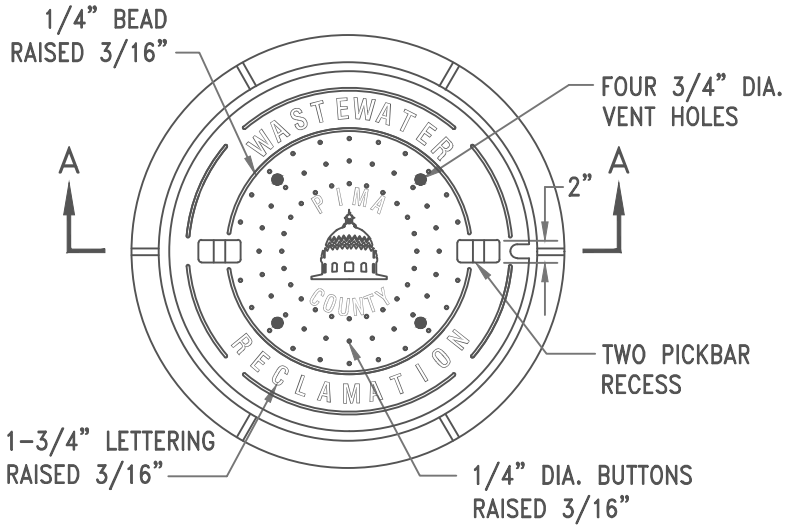

FRAME AND COVER - PLAN VIEW
N.T.S.

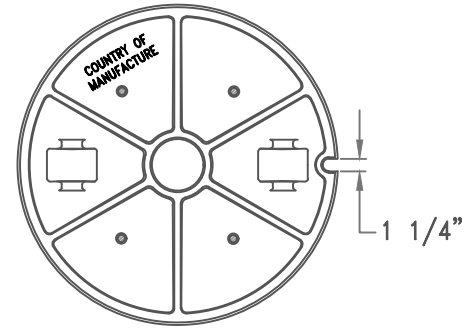

COVER - BOTTOM VIEW
N.T.S.

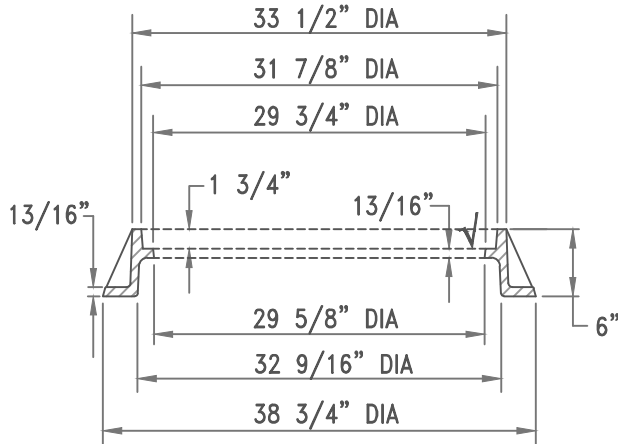

FRAME SECTION A-A
N.T.S.

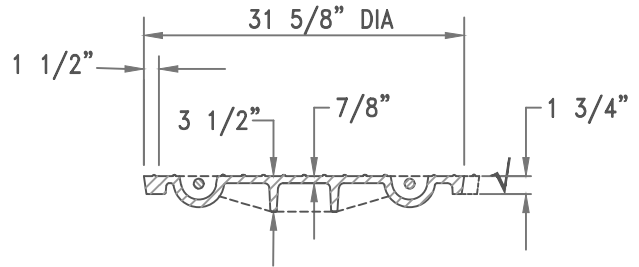

COVER SECTION
N.T.S.

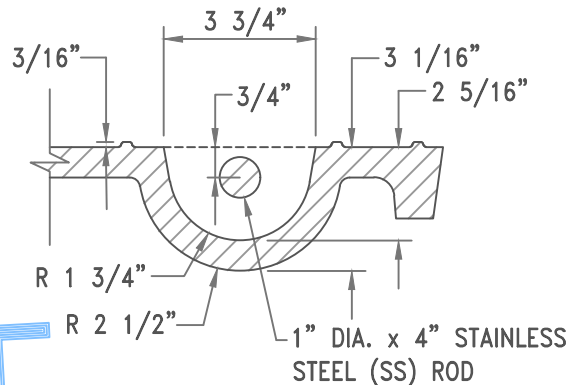

PICKBAR RECESS DETAIL
N.T.S.

√ DENOTES MACHINED SURFACE
DRAFT

NOTES:

1. COVER STYLE MAY SLIGHTLY VARY WITH APPROVAL BY THE FIELD ENGINEER.
2. THE COVER SHALL HAVE PICK BAR RECESSES.
3. FRAME WEIGHT 200 LBS. (APPROX.) AND COVER WEIGHT 217 LBS. (APPROX.)
4. REFER TO SECTION 3.3.2(H) FOR MORE INFORMATION.

ISSUED:	STANDARD DETAIL		DETAIL NO.	
8/92 (WWM-214.0)			RWRD 216	
REVISED:			30" FRAME AND COVER	SHEET 1 OF 1
02/21				

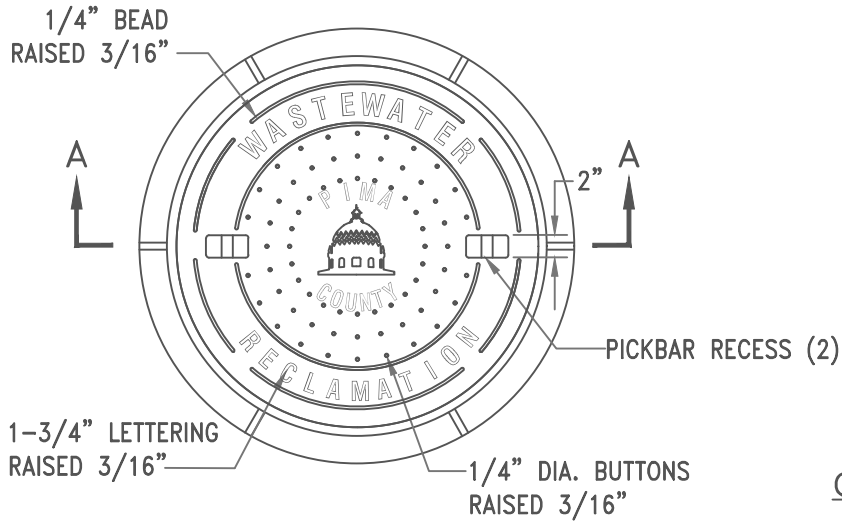

FRAME AND COVER – PLAN VIEW
N.T.S.

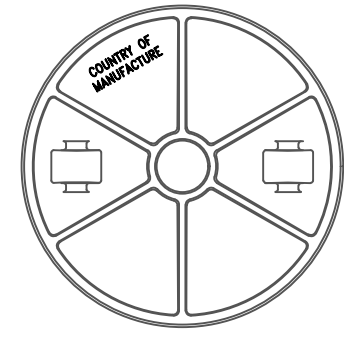

COVER – BOTTOM VIEW
N.T.S.

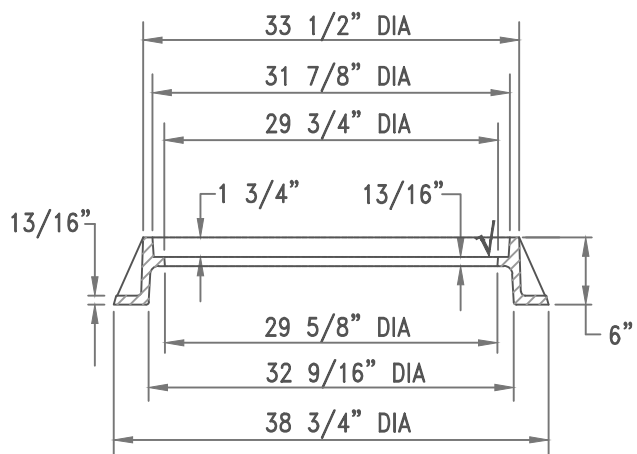

FRAME SECTION A-A
N.T.S.

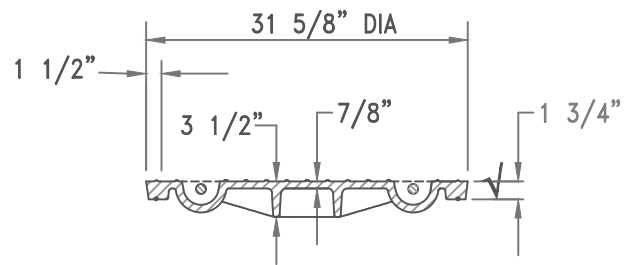

COVER SECTION
N.T.S.

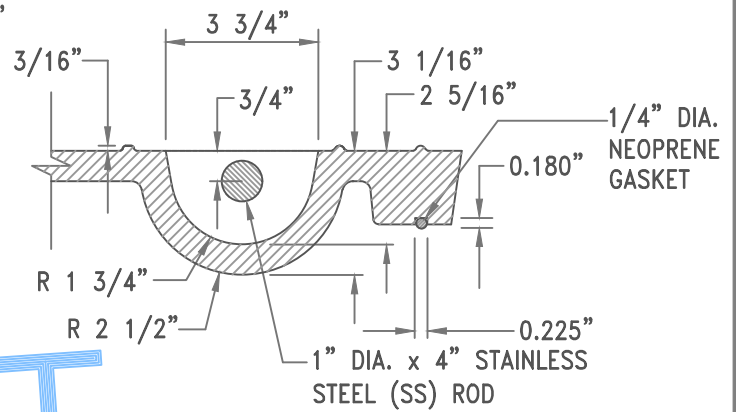

PICKBAR RECESS DETAIL
N.T.S.

✓ DENOTES MACHINED SURFACE

DRAFT

NOTES:

1. COVER STYLE MAY SLIGHTLY VARY WITH APPROVAL BY THE FIELD ENGINEER.
2. THE COVER SHALL HAVE PICK BAR RECESSES. VENT HOLES SHALL NOT BE PROVIDED.
3. FRAME WEIGHT 200 LBS. (APPROX.) AND COVER WEIGHT 217 LBS. (APPROX.)
4. REFER TO SECTION 3.3.2(H) FOR MORE INFORMATION.

ISSUED:	STANDARD DETAIL		DETAIL NO.
8/92 (WWM-214.1)	30" WATERTIGHT FRAME AND COVER		RWRD 217
REVISED:			SHEET 1 OF 1
02/21			

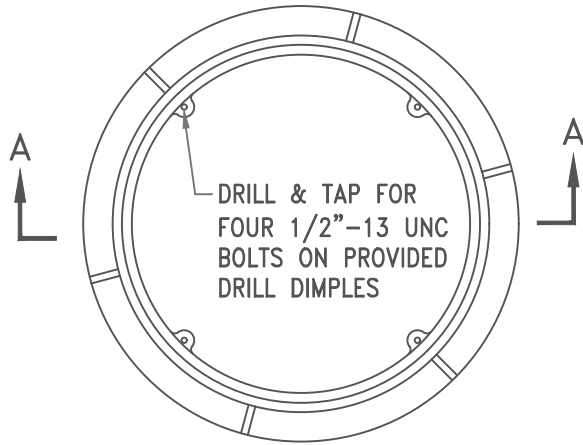

FRAME - PLAN VIEW
N.T.S.

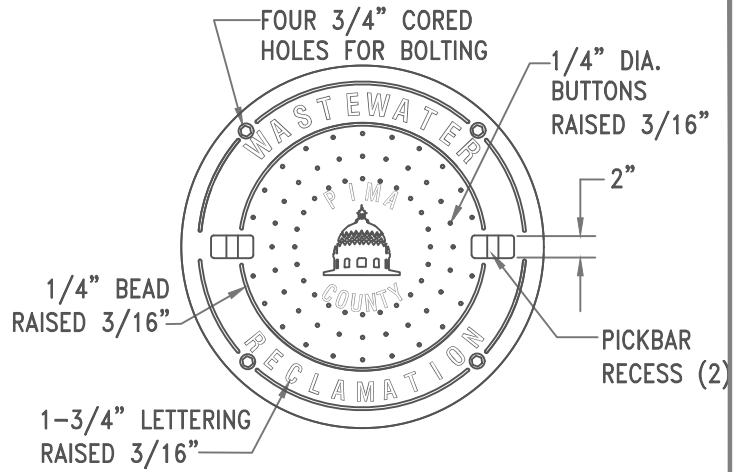

COVER - TOP VIEW
N.T.S.

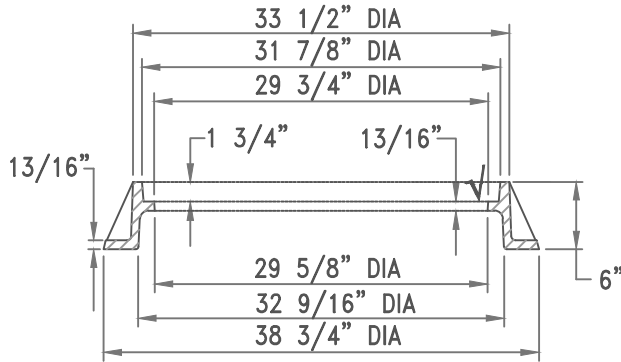

FRAME SECTION A-A
N.T.S.

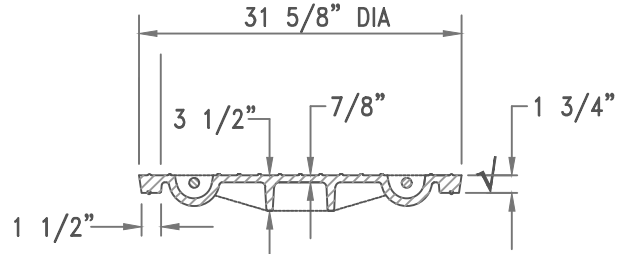

COVER SECTION
N.T.S.

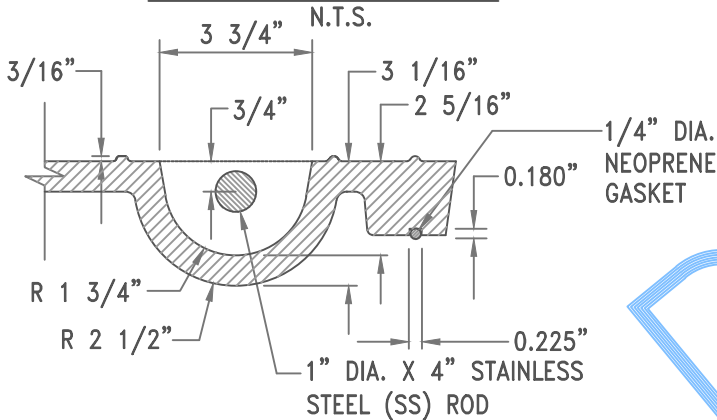

PICKBAR RECESS DETAIL
N.T.S.

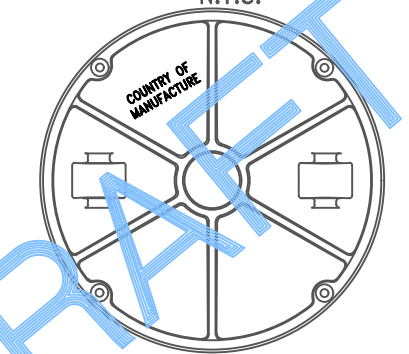

COVER - BOTTOM VIEW
N.T.S.

SS HEX BOLT (1/2"-13 UNC x 1 3/4")
SS WASHER (1/2" I.D. x 1 1/4" O.D.)
RUBBER WASHER (1/2" FLAT)

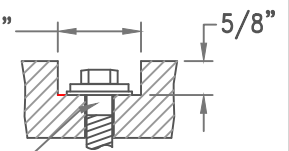

BOLT HOLE DETAIL
N.T.S.

√ DENOTES MACHINED SURFACE

NOTES:

1. COVER STYLE MAY SLIGHTLY VARY WITH APPROVAL BY THE FIELD ENGINEER.
2. THE COVER SHALL HAVE RECESSES FOR PICKBARS. VENT HOLES SHALL NOT BE PROVIDED.
3. FRAME WEIGHT 200 LBS. (APPROX.) AND COVER WEIGHT 217 LBS. (APPROX.)
4. REFER TO SECTION 3.3.2(H) FOR MORE INFORMATION.

ISSUED:	STANDARD DETAIL 30" BOLTED WATERTIGHT FRAME AND COVER		DETAIL NO.
8/92 (WWM-214.2)			RWRD 218
REVISED:			SHEET 1 OF 1
02/21			

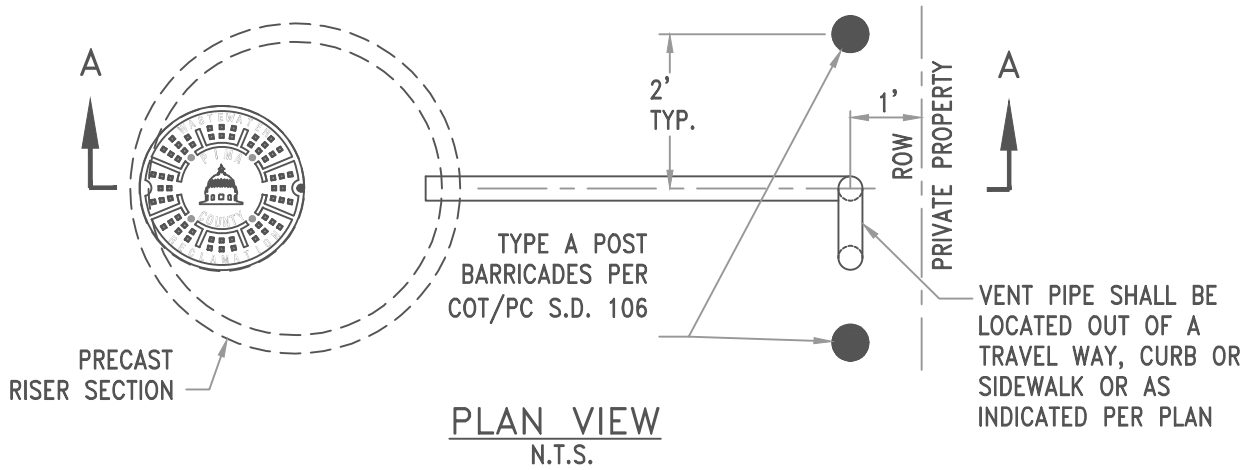

PLAN VIEW
N.T.S.

DRAFT

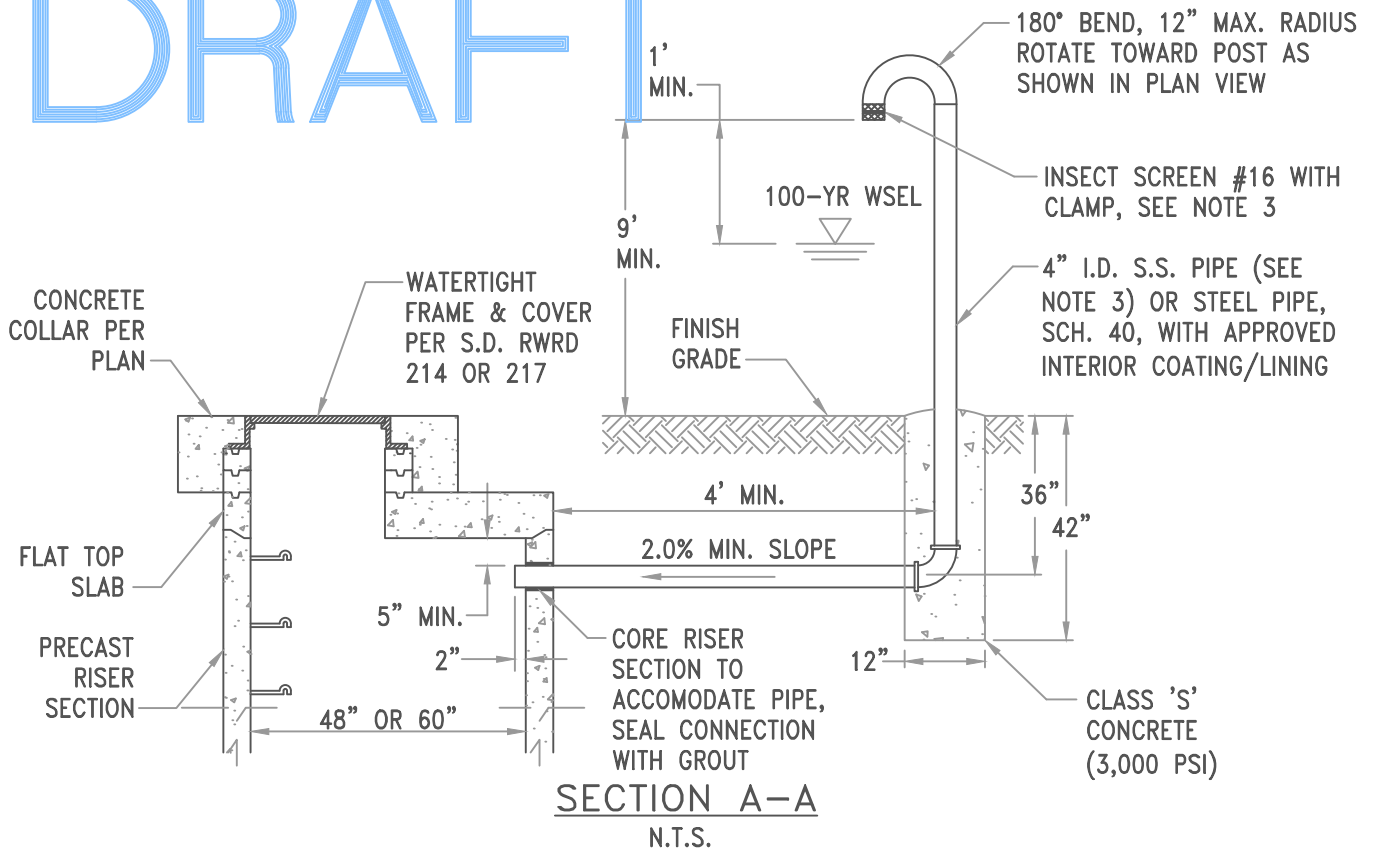

SECTION A-A
N.T.S.

NOTES:

1. INSTALL POLYETHYLENE WRAP FOR BURIED STEEL PIPE PER SUBSECTION 3.2.2(D).
2. EXPOSED PIPE SHALL BE NEAR-WHITE METAL BLAST CLEANED (SSPC-SP10) ON ITS EXTERIOR SURFACE PRIOR TO APPLYING COATINGS. APPLY ONE PRIMER COAT OF TNEMEC N69, ICI-DEVOE BAR-RUST 233H OR APPROVED EQUAL, AT A THICKNESS OF 4 TO 6 MILS. APPLY TWO FINAL COATS OF TNEMEC 1075, ICI-DEVOE DEVTHANE 379 OR APPROVED EQUAL, AT A THICKNESS OF 2 TO 3 MILS PER COAT. PRIMER COLOR SHALL NOT MATCH THE FINAL COAT COLOR. THE FINAL COAT COLOR SHALL BE A DESERT TAN.
3. ALL METAL HARDWARE SHALL BE TYPE 316 STAINLESS STEEL (S.S.) UNLESS APPROVED BY THE FIELD ENGINEER.

ISSUED:	STANDARD DETAIL		DETAIL NO.
8/92 (WWM-221.1)	MANHOLE VENT ASSEMBLY		RWRD 223
REVISED:		SHEET 1 OF 1	
02/21			

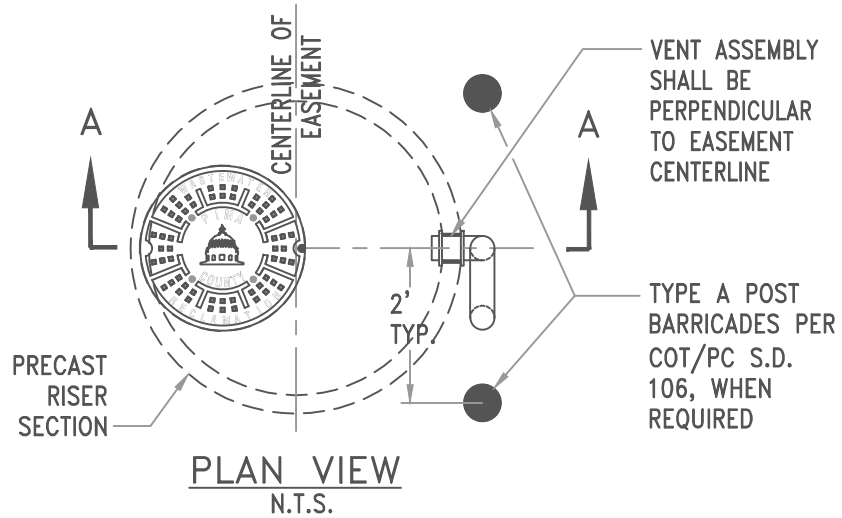

180° BEND, 12" MAX. RADIUS, ROTATE TOWARD POST AS SHOWN IN PLAN VIEW

INSECT SCREEN WITH CLAMP, SEE NOTE 3

4" I.D. S.S. PIPE (SEE NOTE 3) OR STEEL PIPE, SCH. 40, WITH APPROVED INTERIOR COATING/LINING

CONCRETE COLLAR PER S.D. RWRD 212

WATERTIGHT FRAME & COVER PER S.D. RWRD 214 OR 217

FLAT TOP SLAB

PRECAST RISER SECTION

5" MIN.

48" OR 60"

FILL WITH GROUT TO INVERT OF VENT PIPE

1' MIN.

100-YR WSEL

9' MIN.

FINISH GRADE

SEE DETAIL RIGHT

CORE 5" DIA. HOLE INTO RISER SECTION AND SEAL WITH GROUT, TYP.

COAT ALL EXPOSED METAL SURFACES

VENT PIPE INVERT

1/4" TYP.

2% MIN.

1-1/2"

TWO 7" X 7" X 1/4" STEEL PLATES WITH 4-5/8" HOLE

JOINT SHALL BE FULLY WELDED SO THAT JOINT STRENGTH IS EQUAL TO OR GREATER THAN PIPE SECTION, TYP.

VENT PIPE CONNECTION
N.T.S.

SECTION A-A
N.T.S.

NOTE:

SEE S.D. RWRD 223 FOR NOTES 1, 2 AND 3.

DRAFT

ISSUED:	STANDARD DETAIL		DETAIL NO.
8/92 (WWM-221.2)	MODIFIED		RWRD 224
REVISED:	MANHOLE VENT ASSEMBLY		SHEET 1 OF 1
02/21			

FOR EXISTING BASES, GRIND OUT
1" MIN. DEPTH OF EXISTING FLOW
CHANNEL AND THOROUGHLY CLEAN

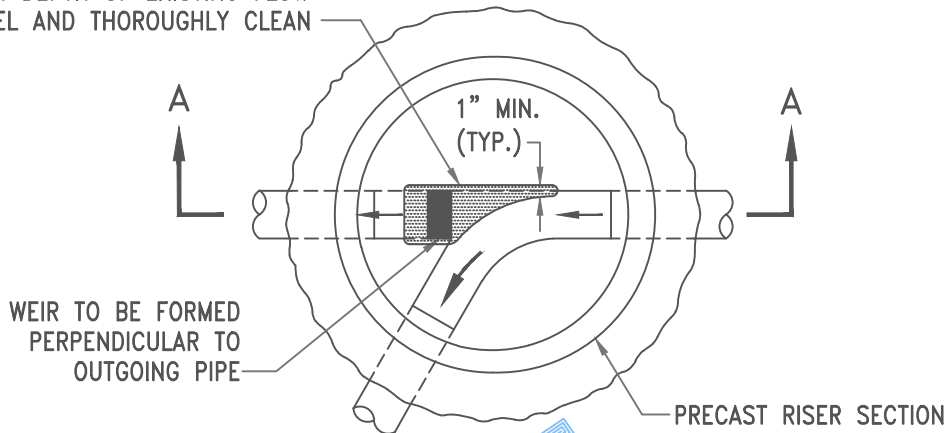

PLAN VIEW
N.T.S.

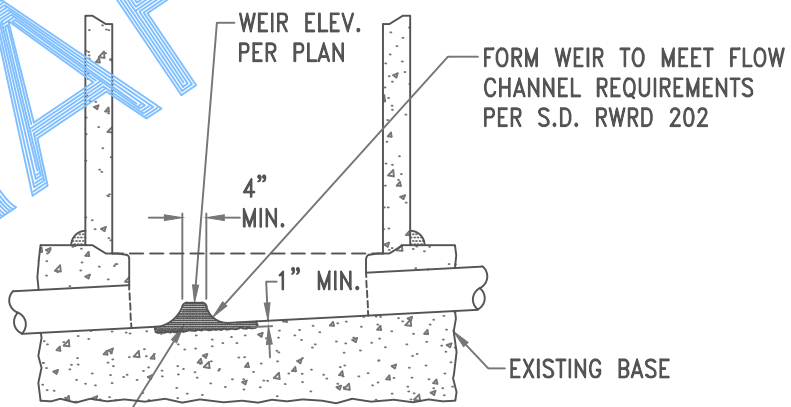

SEE NOTES 2 & 3

SECTION A-A
N.T.S.

NOTE:

1. REVIEW AND APPROVAL BY PCRWRD TECHNICAL SERVICES AND ENGINEERING REQUIRED PRIOR TO PLAN APPROVAL.
2. FOR EXISTING BASES, APPLY AN APPROVED CONCRETE ADHESIVE AND USE CLASS 'S' CONCRETE (3,000 PSI) TO FORM WEIR.
3. FOR NEW BASES, CONSTRUCT BASE IN ACCORDANCE WITH DETAIL RWRD 200 OR 201 AND FORM WEIR AS PART OF BASE CONSTRUCTION.

ISSUED:	STANDARD DETAIL		DETAIL NO.
8/92 (WWM-219)			RWRD 226
REVISED:	CONCRETE WEIR FOR DIVERSION MANHOLES		SHEET 1 OF 1
02/21			

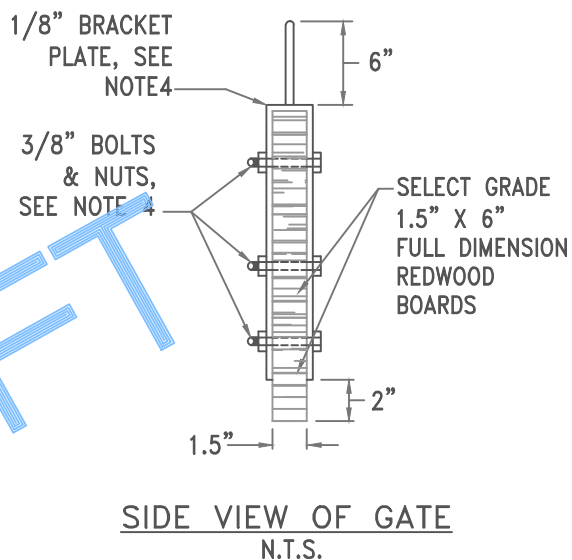
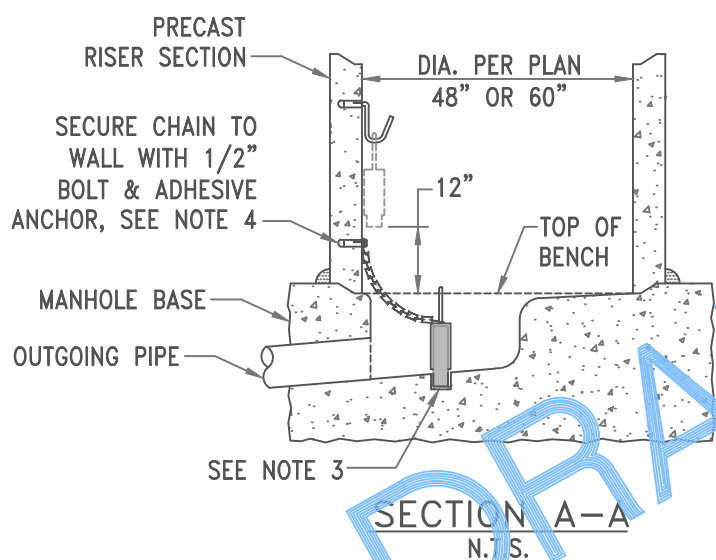
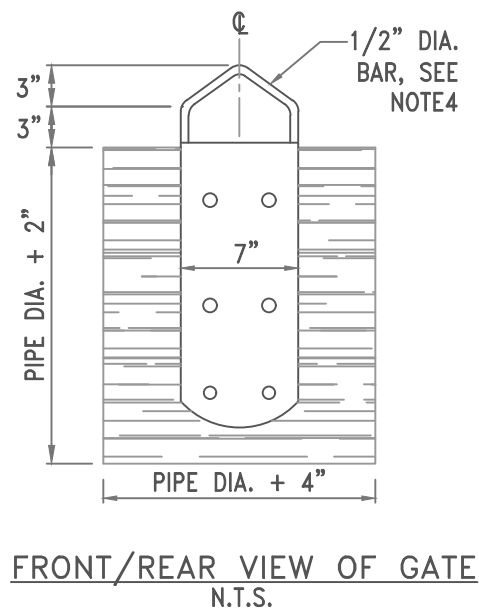
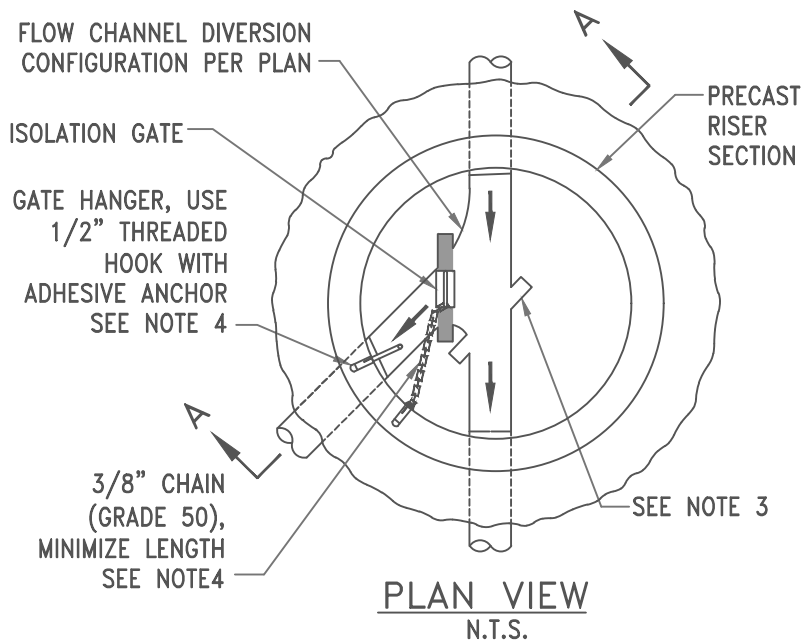

NOTES:

1. REVIEW AND APPROVAL BY RWRD TECHNICAL SERVICES AND ENGINEERING REQUIRED PRIOR TO PLAN APPROVAL.
2. REDWOOD GATES FOR FLOW CHANNEL ISOLATION (AS SHOWN) SHALL BE USED FOR OUTGOING PIPE DIAMETERS OF 30" OR LESS.
3. FORM OR GRIND 2" WIDE BY 2" DEEP NOTCH INTO FLOW CHANNEL TO SECURE GATE IN PLACE. PLACE NOTCH AS CLOSE TO THE EDGE OF THE FLOW CHANNEL AS POSSIBLE. SHOP DRAWINGS FOR GATES AND LOCATION WITHIN MANHOLE SHALL BE SUBMITTED BY THE CONTRACTOR FOR REVIEW AND APPROVAL BY THE FIELD ENGINEER.
4. ALL METAL HARDWARE SHALL BE TYPE 316 STAINLESS STEEL UNLESS APPROVED BY THE FIELD ENGINEER.

ISSUED:	STANDARD DETAIL		DETAIL NO.
8/92 (WWM-220)			RWRD 228
REVISED:	REDWOOD ISOLATION GATE		SHEET 1 OF 1
02/21			

DRAFT

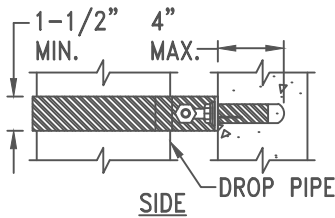
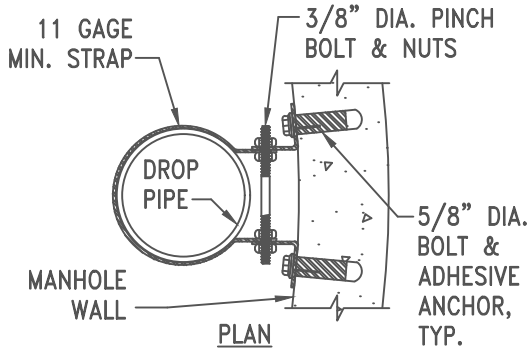
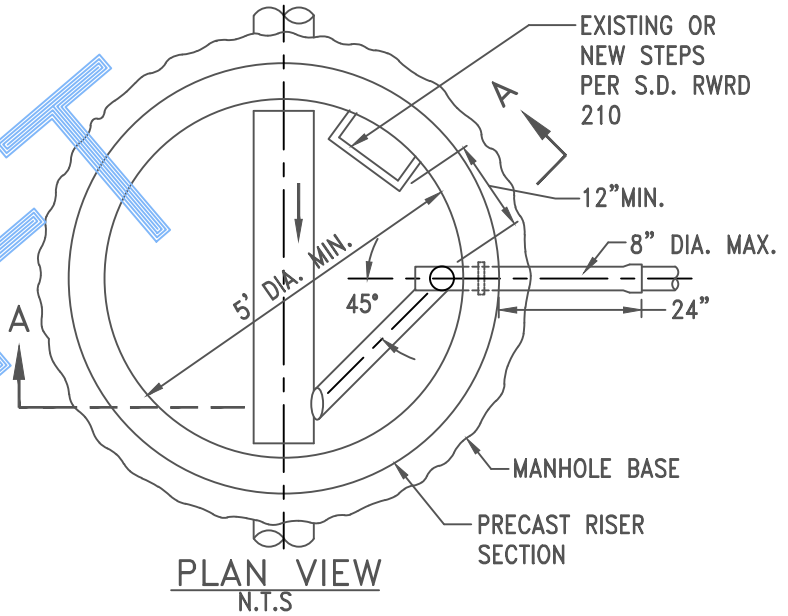

BRACKET DETAIL
N.T.S

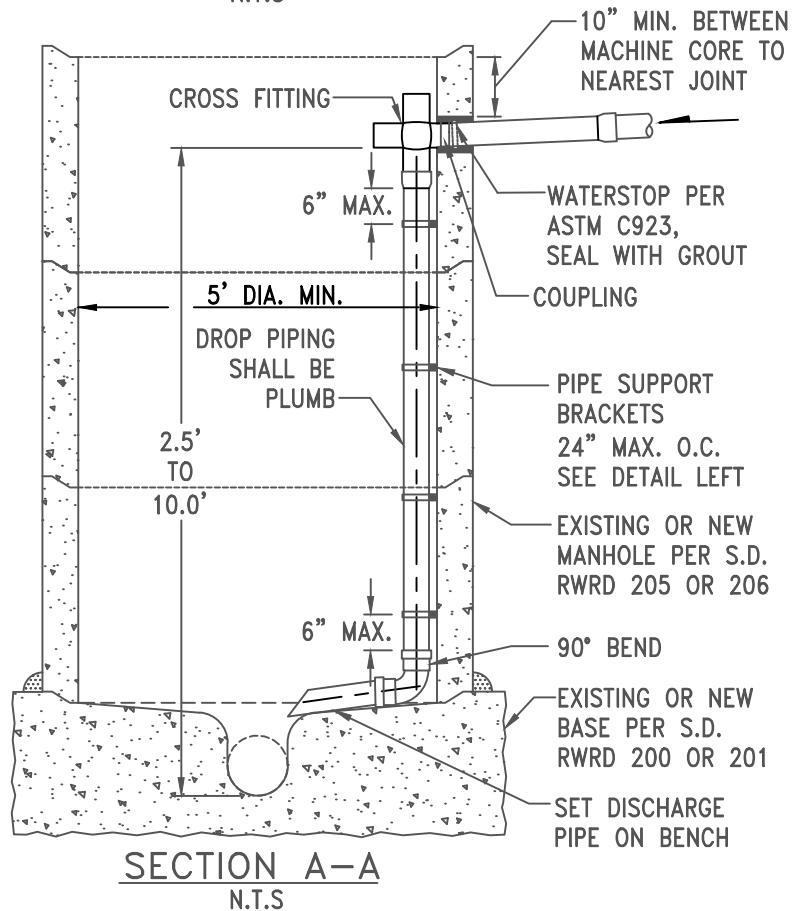

NOTES:

1. THIS STANDARD DETAIL MAY BE USED BY THE CONTRACTOR IF APPROVED IN THE PLANS AND IN WRITING BY PCRWRD TECHNICAL SERVICES & ENGINEERING.
2. DROP PIPING MATERIALS SHALL BE SOLVENT WELDED PVC (SDR-26) AND THE SAME DIAMETER AS THE INCOMING PIPE. ALL HARDWARE SHALL BE TYPE 316 STAINLESS STEEL UNLESS OTHERWISE APPROVED BY THE FIELD ENGINEER.

ISSUED:	STANDARD DETAIL		DETAIL NO.
02/21	INTERNAL DROP		RWRD 231
REVISED:	MANHOLE CONNECTION	WASTEWATER RECLAMATION	SHEET 1 OF 1

TOP VIEW

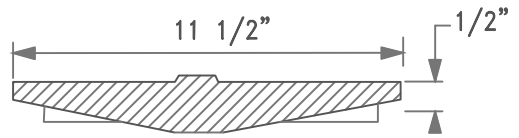
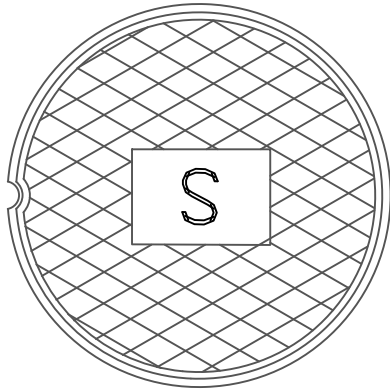

COVER

EJ FOUNDRY V8502
OR EQUAL

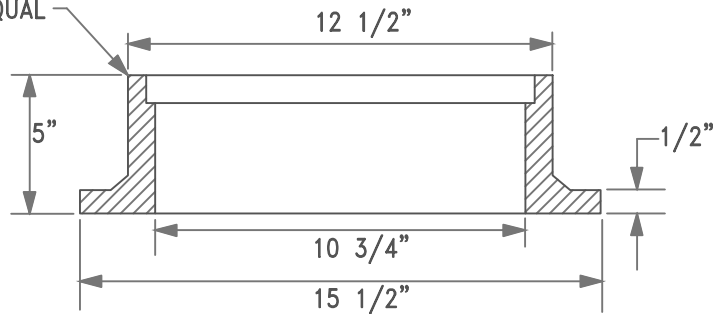

RING

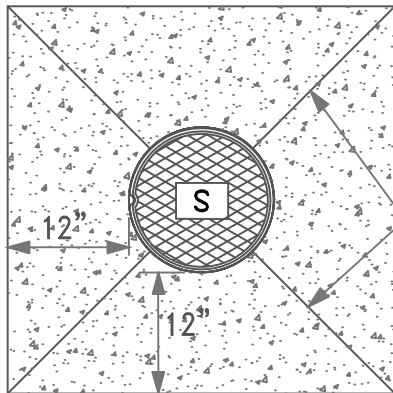

RADIAL SCORE
MARKS (TYP)

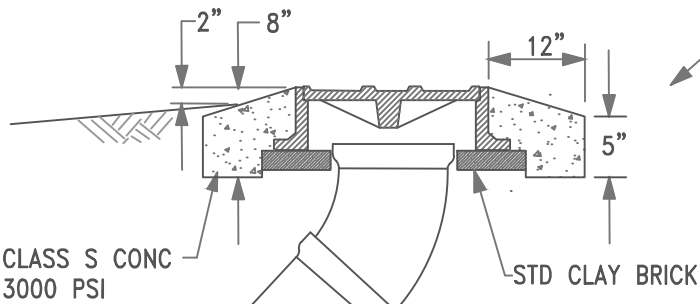

CLASS S CONC
3000 PSI

STD CLAY BRICK

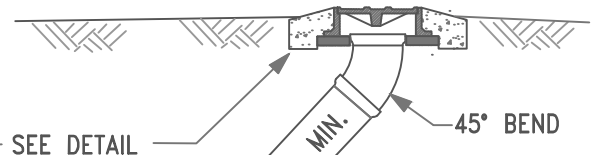

SEE DETAIL

45° BEND

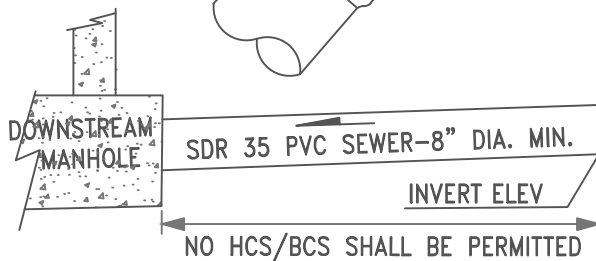

SDR 35 PVC SEWER-8" DIA. MIN.

INVERT ELEV

NO HCS/BCS SHALL BE PERMITTED

THRUST BLOCK
CLASS S CONC
3000 PSI

PLUG END

45° WYE

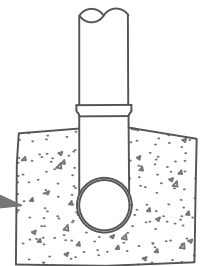

2' MIN.

NOTES:

1. THIS STANDARD DETAIL MAY ONLY BE USED IN ACCORDANCE WITH SEC. 5.2.18.
2. DROP PIPING AND FITTINGS SHALL BE THE SAME DIAMETER AND TYPE AS THE OUTGOING SEWER LINE.
3. FINISH CONCRETE COLLAR EDGES AND SCORE MARKS WITH HAND TROWEL HAVING 1/4" RADIUS.

ISSUED:	STANDARD DETAIL		DETAIL NO.
02/21	TEMPORARY CLEANOUT FOR PHASED PROJECTS		RWRD 232
REVISED:			SHEET 1 OF 1

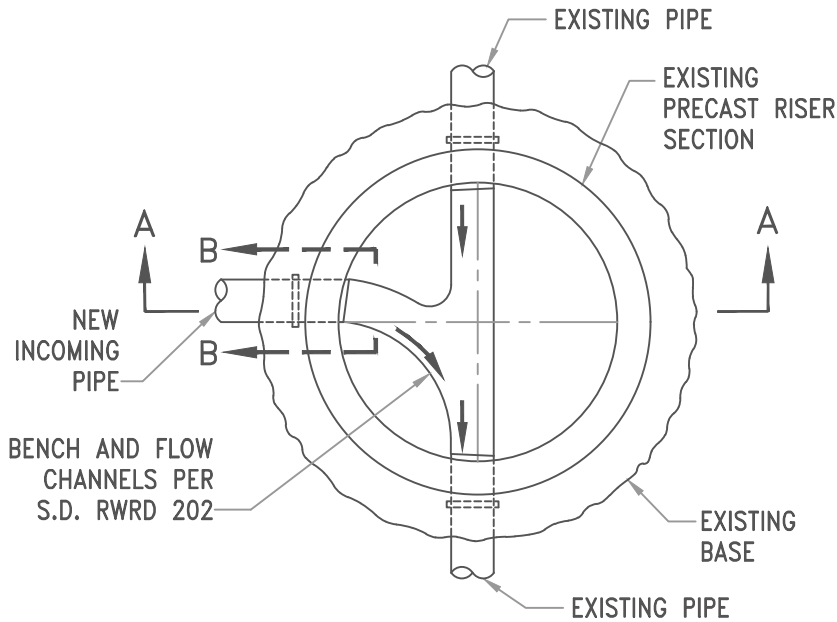

PLAN VIEW
N.T.S.

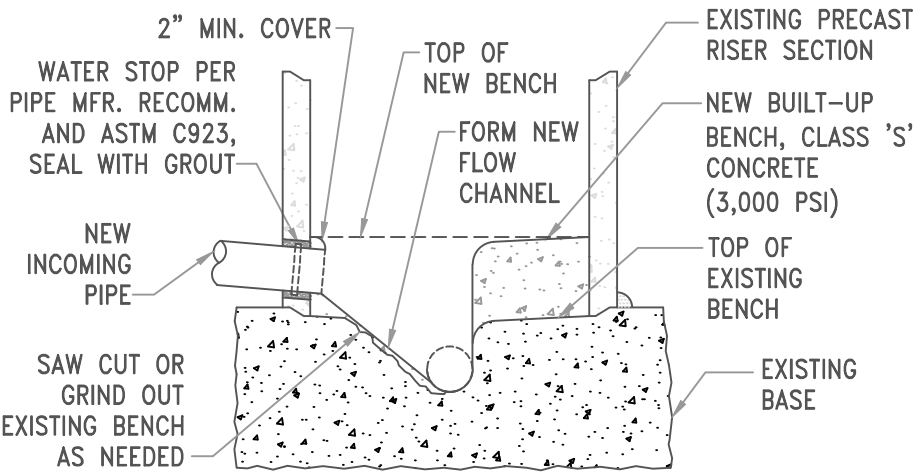
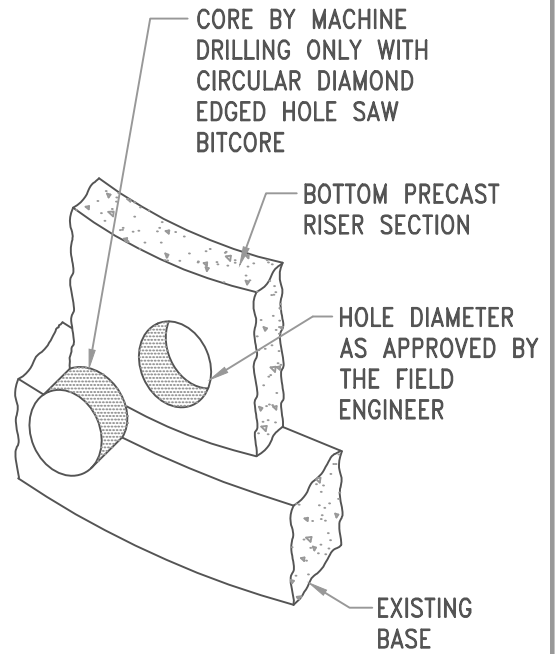

SECTION A-A
N.T.S.

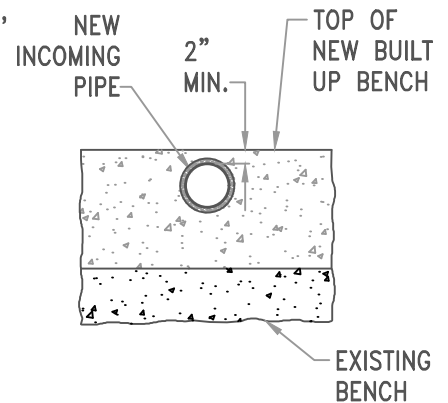

SECTION B-B
N.T.S.

DRAFT

NOTES:

1. EXISTING BENCH SHALL BE THOROUGHLY CLEANED PRIOR TO CONSTRUCTING NEW BUILT-UP BENCH.
2. CONNECTIONS TO EXISTING MANHOLES SHALL BE INSPECTED AND APPROVED BY THE FIELD ENGINEER.

ISSUED:	STANDARD DETAIL CONNECTION TO EXISTING MANHOLE BARREL	 PIMA COUNTY WASTEWATER RECLAMATION	DETAIL NO.
8/92 (WWM-301)			RWRD 300
REVISED:			SHEET 1 OF 1
12/12			

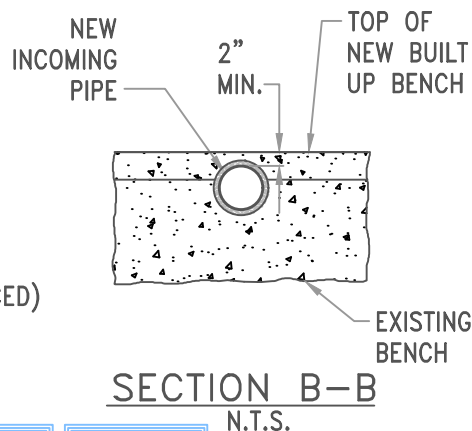
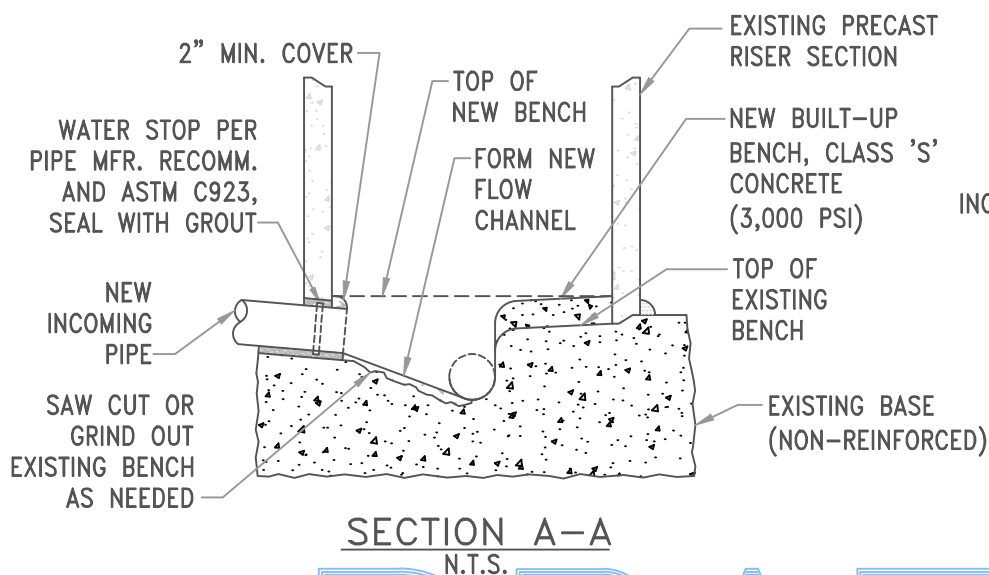
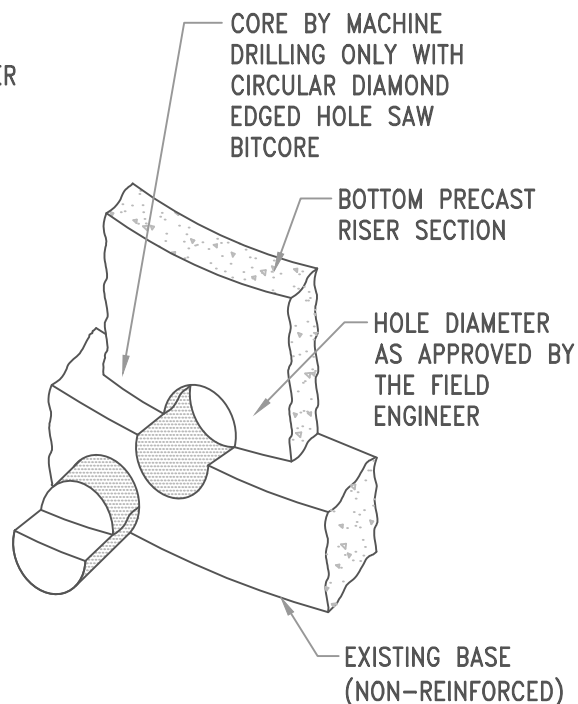
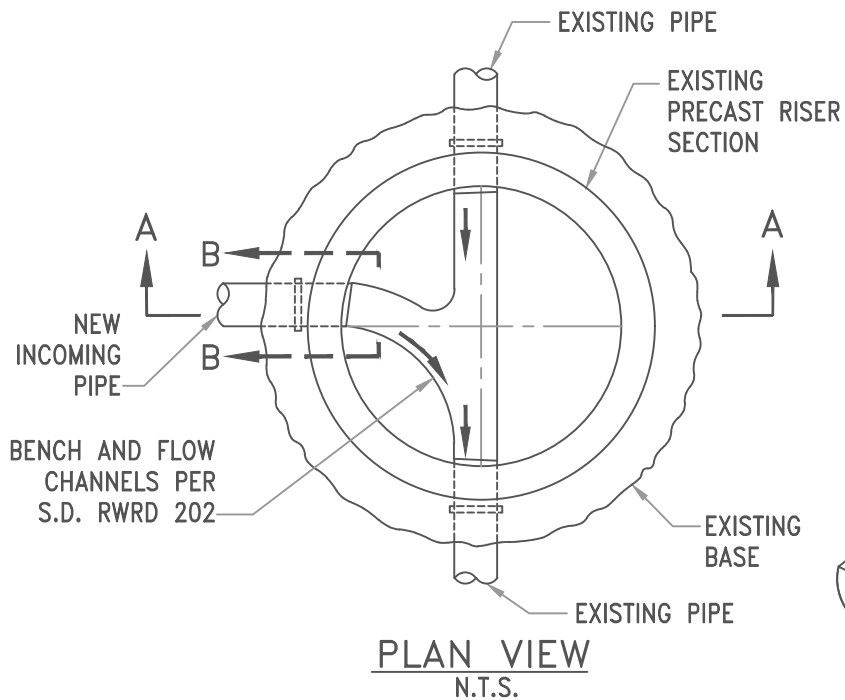

DRAFT

NOTES:

1. EXISTING BENCH SHALL BE THOROUGHLY CLEANED PRIOR TO CONSTRUCTING NEW BUILT-UP BENCH.
2. CONNECTIONS TO EXISTING MANHOLES SHALL BE INSPECTED AND APPROVED BY THE FIELD ENGINEER.

ISSUED:	STANDARD DETAIL		DETAIL NO.
8/92	CONNECTION TO EXISTING MANHOLE BASE		RWRD 301
REVISED:			
12/12			SHEET 1 OF 1

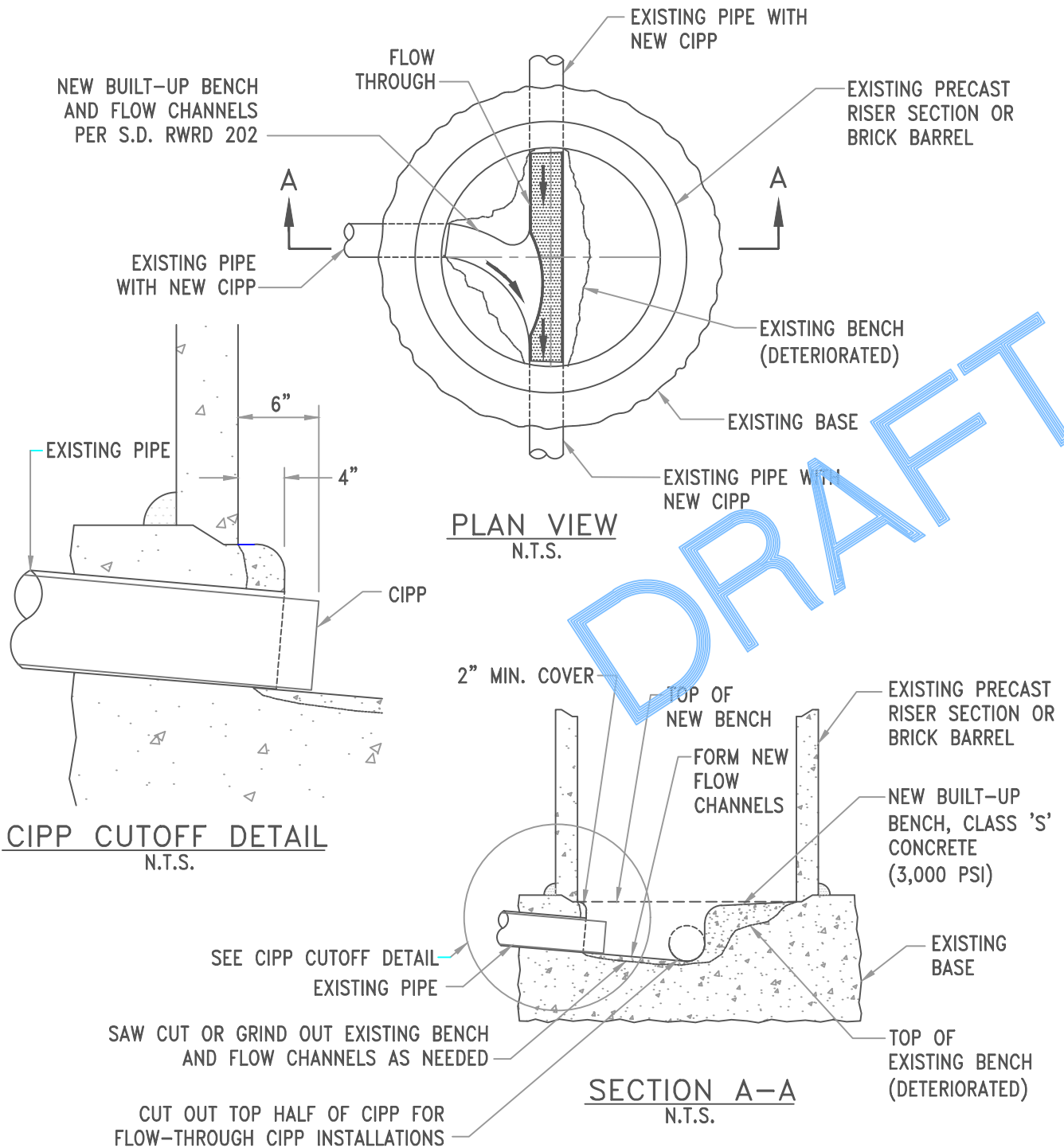

DRAFT

NOTES:

1. THIS DETAIL SHALL APPLY TO THE REHABILITATION OF EXISTING MANHOLES WITH DETERIORATED BENCHES AND THE REHABILITATION OF EXISTING SEWER LINES BY METHOD OF CURED IN PLACE PIPE (CIPP).
2. EXISTING BENCH AND FLOW CHANNELS SHALL BE THOROUGHLY CLEANED PRIOR TO CONSTRUCTING NEW BUILT UP BENCH.

ISSUED:	STANDARD DETAIL		DETAIL NO.
12/12	RAISE EXISTING BENCH		RWRD 302
REVISED:			SHEET 1 OF 1

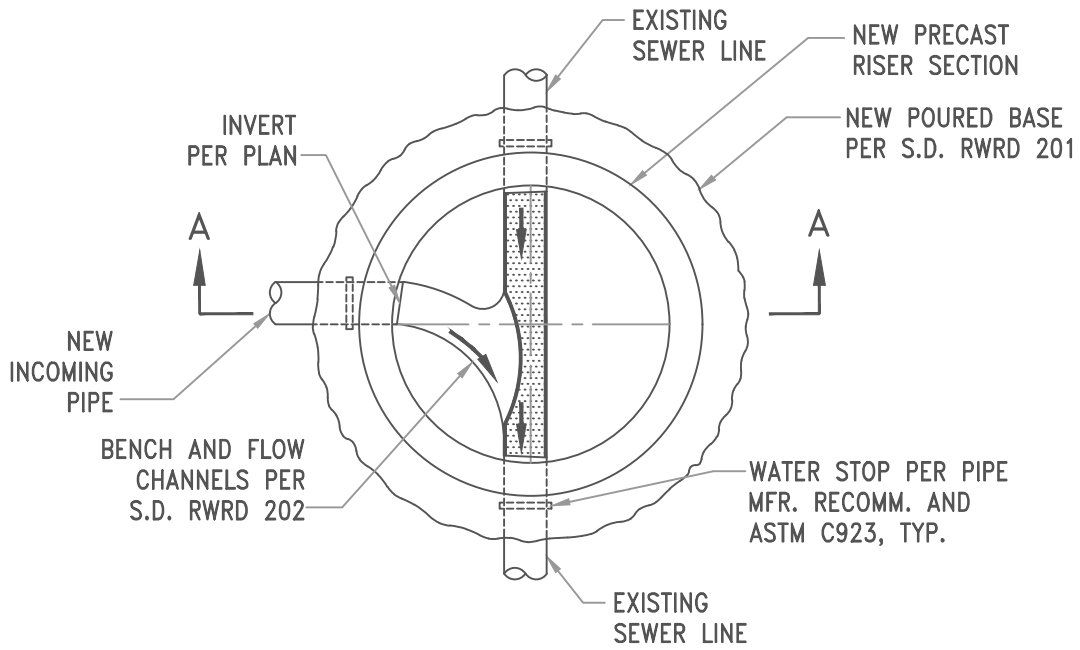

PLAN VIEW
N.T.S.

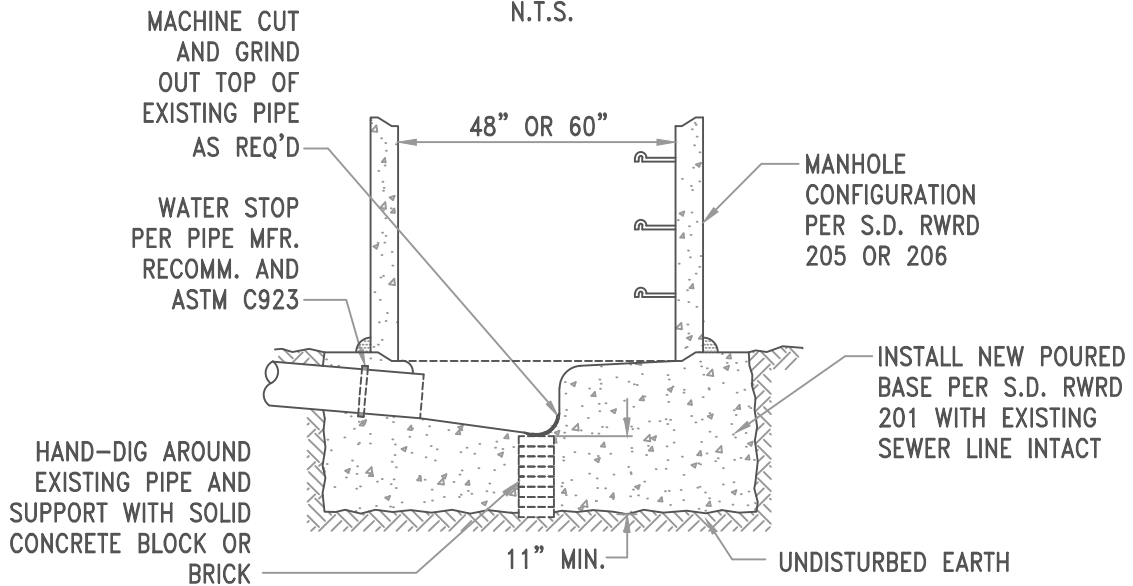

SECTION A-A
N.T.S.

DRAFT

NOTES:

1. FOUNDATION PER S.D. RWRD 104 TO THE FIRST JOINT BEYOND OPEN TRENCH CONDITIONS MAY BE REQUIRED DEPENDING ON DEPTH OF EXCAVATION AND TYPE OF SOIL.
2. SEE SUBSECTION 3.3.3(D)(v) FOR MORE INFORMATION.

ISSUED:	STANDARD DETAIL NEW MANHOLE OVER EXISTING SEWER LINE	 PIMA COUNTY WASTEWATER RECLAMATION	DETAIL NO.
8/92			RWRD 303
REVISED:			SHEET 1 OF 1
12/12			

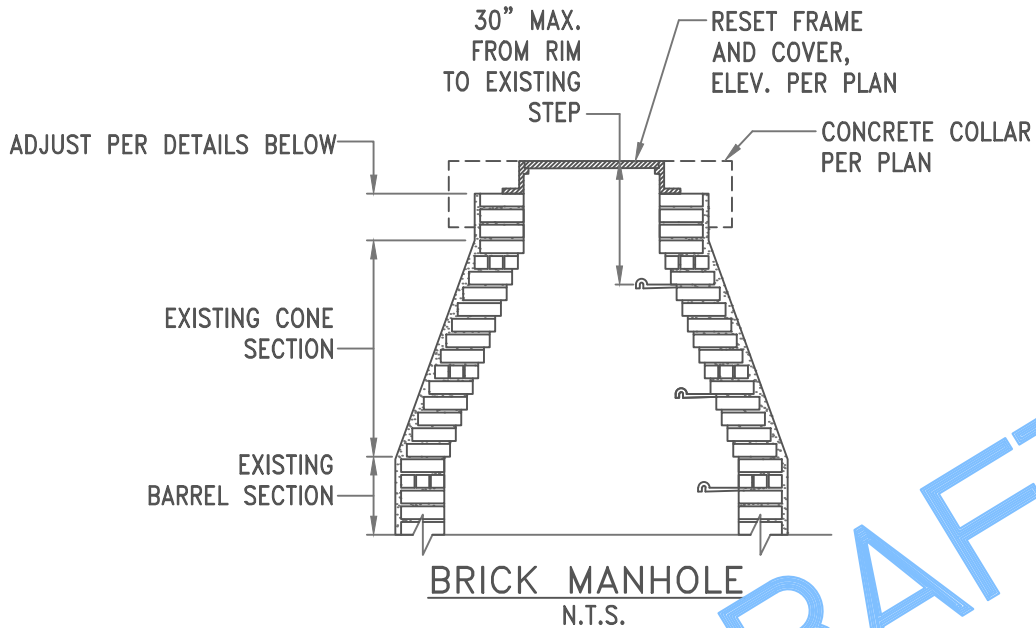

DRAFT

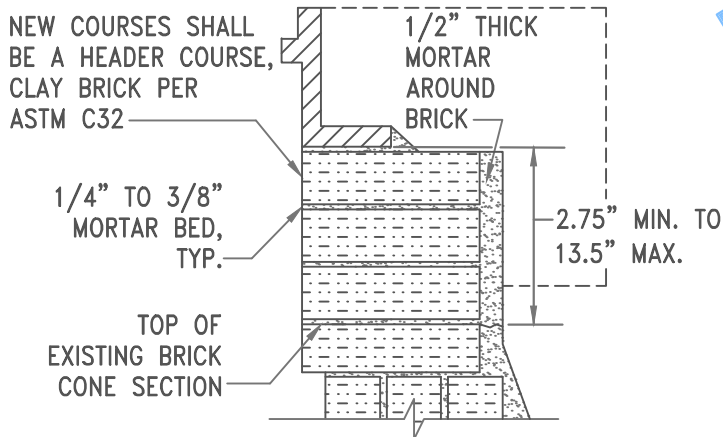

BRICK ADJUSTMENT
N.T.S.

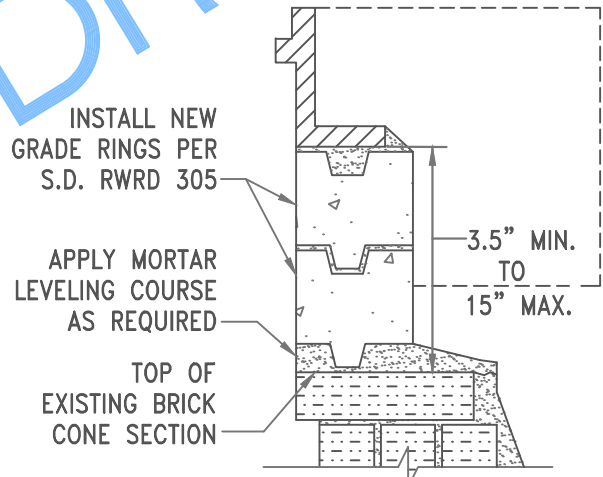

GRADE RING ADJUSTMENT
N.T.S.

NOTES:

1. A SEWER CONSTRUCTION PERMIT FROM PCRWRD IS REQUIRED PRIOR TO REMOVAL OF THE FRAME AND COVER ON EXISTING PUBLIC MANHOLES. GRADE ADJUSTMENT WORK SHALL BE INSPECTED AND APPROVED BY THE FIELD ENGINEER.
2. RECONSTRUCTION OF THE EXISTING BRICK MANHOLE SHALL BE REQUIRED FOR VIOLATION OF THE DIMENSIONAL RANGES NOTED ABOVE OR THE AGE, CONDITION OR TYPE OF MATERIAL WARRANTS SUCH REPLACEMENT, AS DIRECTED BY THE FIELD ENGINEER.
3. SEE SUBSECTION 3.3.3(D)(iv) FOR MORE INFORMATION.

ISSUED:	STANDARD DETAIL		DETAIL NO.
8/92	GRADE ADJUSTMENT FOR EXISTING BRICK MANHOLE		RWRD 304
REVISED:			SHEET 1 OF 1
02/21			

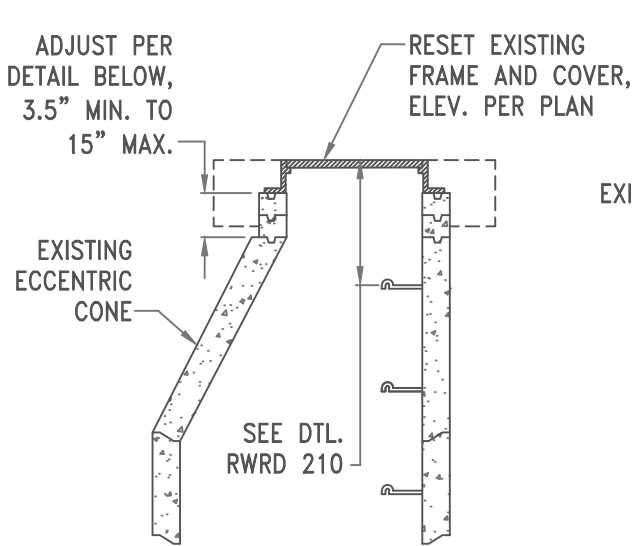

**PRECAST MANHOLE
WITH CONE SECTION**
N.T.S.

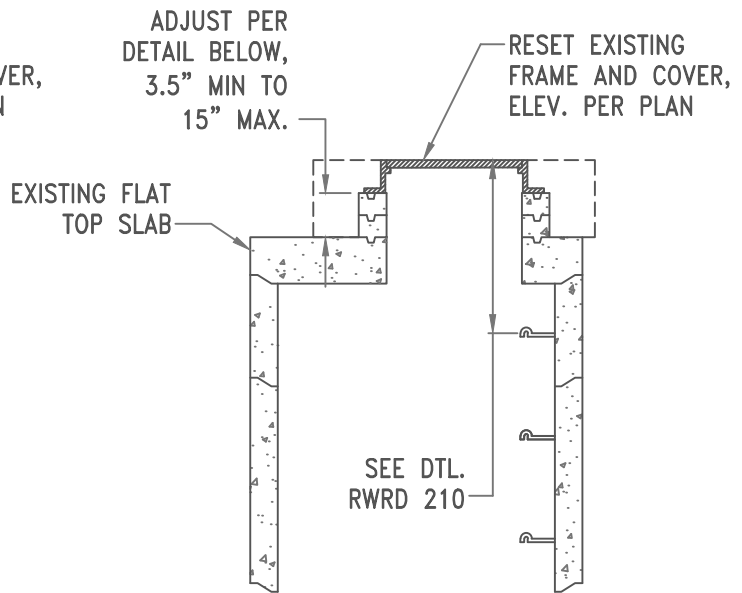

**PRECAST MANHOLE
WITH FLAT-TOP SLAB**
N.T.S.

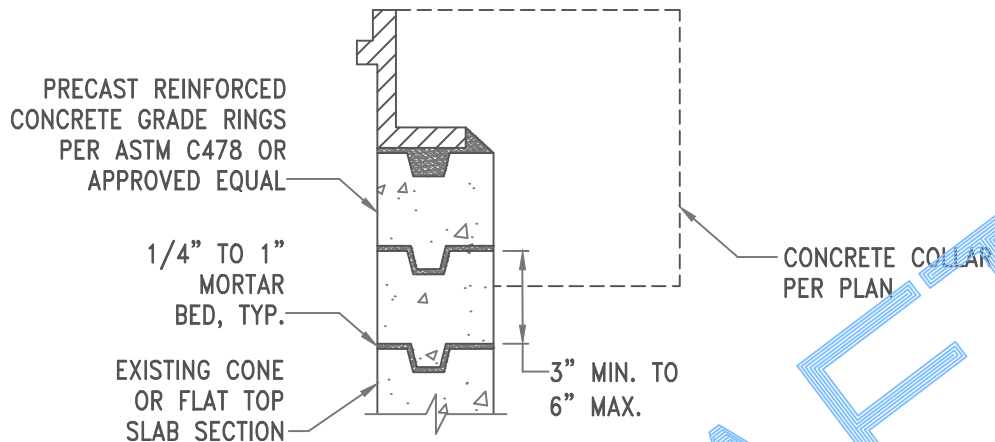

GRADE RING DETAIL
N.T.S.

NOTES:

1. A SEWER CONSTRUCTION PERMIT FROM PCRWRD IS REQUIRED PRIOR TO REMOVAL OF THE FRAME AND COVER ON EXISTING PUBLIC MANHOLES. GRADE ADJUSTMENT WORK SHALL BE INSPECTED AND APPROVED BY THE FIELD ENGINEER.
2. RECONSTRUCTION OF THE EXISTING PRECAST MANHOLE SHALL BE REQUIRED FOR VIOLATION OF THE DIMENSIONAL RANGES NOTED ABOVE, AGE OF THE EXISTING MANHOLE, CONDITION OR TYPE OF MATERIAL WARRANTING SUCH REPLACEMENT, AS DIRECTED BY THE FIELD ENGINEER.
3. SEE SUBSECTION 3.3.3(D)(i) FOR MORE INFORMATION.

ISSUED:	STANDARD DETAIL		DETAIL NO.
8/92			RWRD 305
REVISED:	GRADE ADJUSTMENT FOR EXISTING PRECAST MANHOLE		SHEET 1 OF 1
02/21			

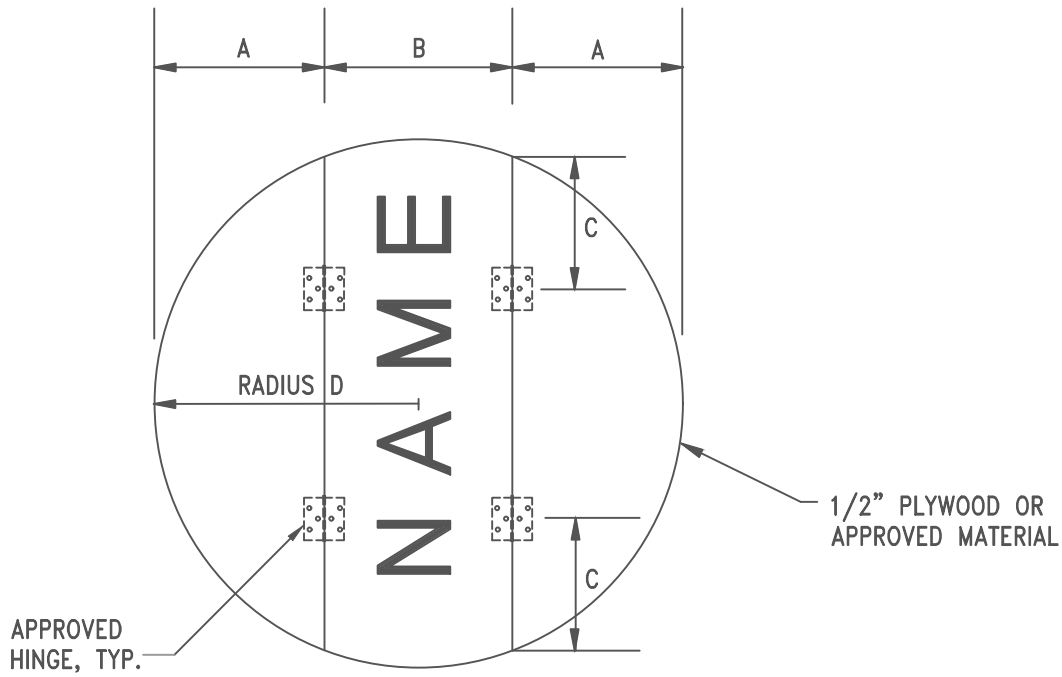

DESCRIPTION	A	B	C	D
48" DIA. MH W/24" FRAME & COVER	13"	20"	12"	23"
60" DIA. MH W/30" FRAME & COVER	19"	20"	14"	29"
60" DIA. MH W/24" FRAME & COVER	19"	20"	14"	29"

DRAFT

NOTES:

1. FOR CONSTRUCTION DETAILS SEE STANDARD SPECIFICATIONS SUBSECTION 3.3.3(D)(i).
2. FLOW CHANNEL COVERS SHALL CLEARLY IDENTIFY THE NAME OF THE RESPONSIBLE CONTRACTOR.
3. THE CONTRACTOR'S NAME SHALL BE LEGIBLY SHOWN ON THE COVER AND BE OF SUFFICIENT SIZE TO BE READ FROM GROUND SURFACE.
4. UNREADABLE NAMES SHALL BE CAUSE FOR REJECTION OF THE COVER BY THE RWRD INSPECTOR.

ISSUED:	STANDARD DETAIL	DETAIL NO.
8/92 (WWM-307)	FLOW CHANNEL COVER	RWRD 306
REVISED:		SHEET 1 OF 1
02/21		

CLASS 'S' CONCRETE
(3,000 PSI),
SEE NOTE 1

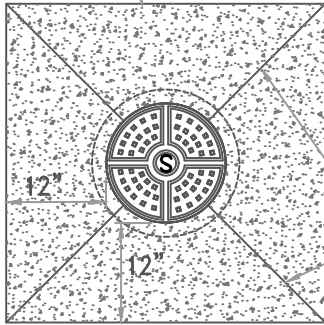

4 RADIALLY
EQUAL SCORE
MARKS,
SEE NOTE 2

PLAN VIEW
SQUARE COLLAR
(UNPAVED AREAS)
N.T.S.

CLASS 'S' CONCRETE
(3,000 PSI),
SEE NOTE 1

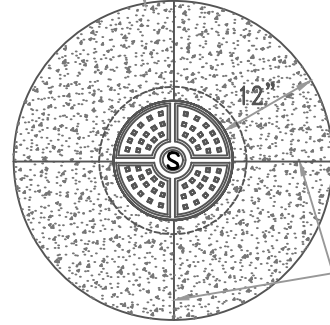

4 RADIALLY
EQUAL SCORE
MARKS,
SEE NOTE 2

PLAN VIEW
ROUND COLLAR
(PAVED AREAS)
N.T.S.

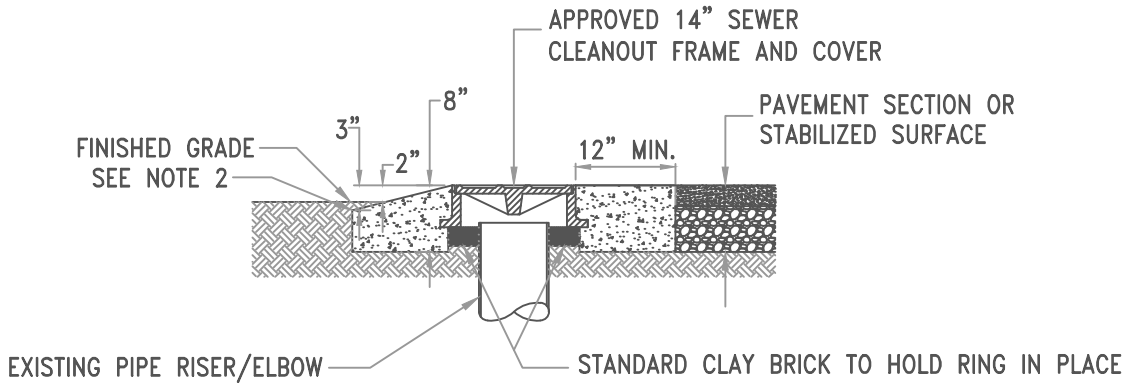

SECTION A-A
N.T.S.

DRAFT

NOTES:

1. ALL COLLARS SHALL BE FORMED.
2. FINISH ALL CONCRETE EDGES AND SCORE MARKS WITH A HAND TROWEL HAVING A 1/4" RADIUS. EXPOSED CONCRETE SURFACES SHALL HAVE A MEDIUM BROOM FINISH.

ISSUED:	STANDARD DETAIL GRADE ADJUSTMENT FOR EXISTING CLEANOUTS	 PIMA COUNTY WASTEWATER RECLAMATION	DETAIL NO.
10/15			RWRD 307
REVISED:			SHEET 1 OF 1

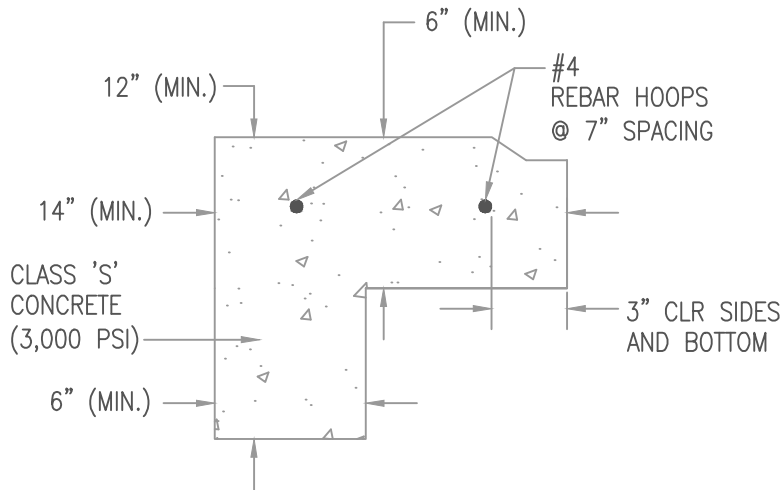
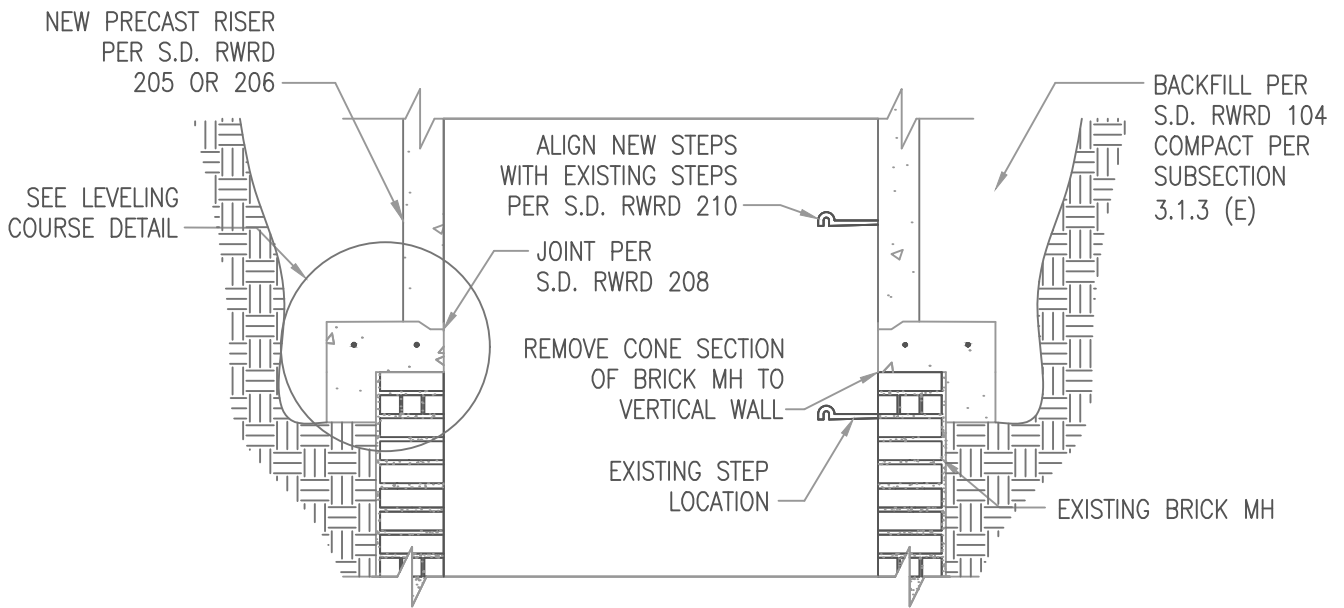

LEVELING COURSE DETAIL
N.T.S.

DRAFT

ISSUED:	STANDARD DETAIL		DETAIL NO.
10/15	LEVELING COURSE FOR BRICK MH RECONSTRUCTION		RWRD 308
REVISED:			SHEET 1 OF 1

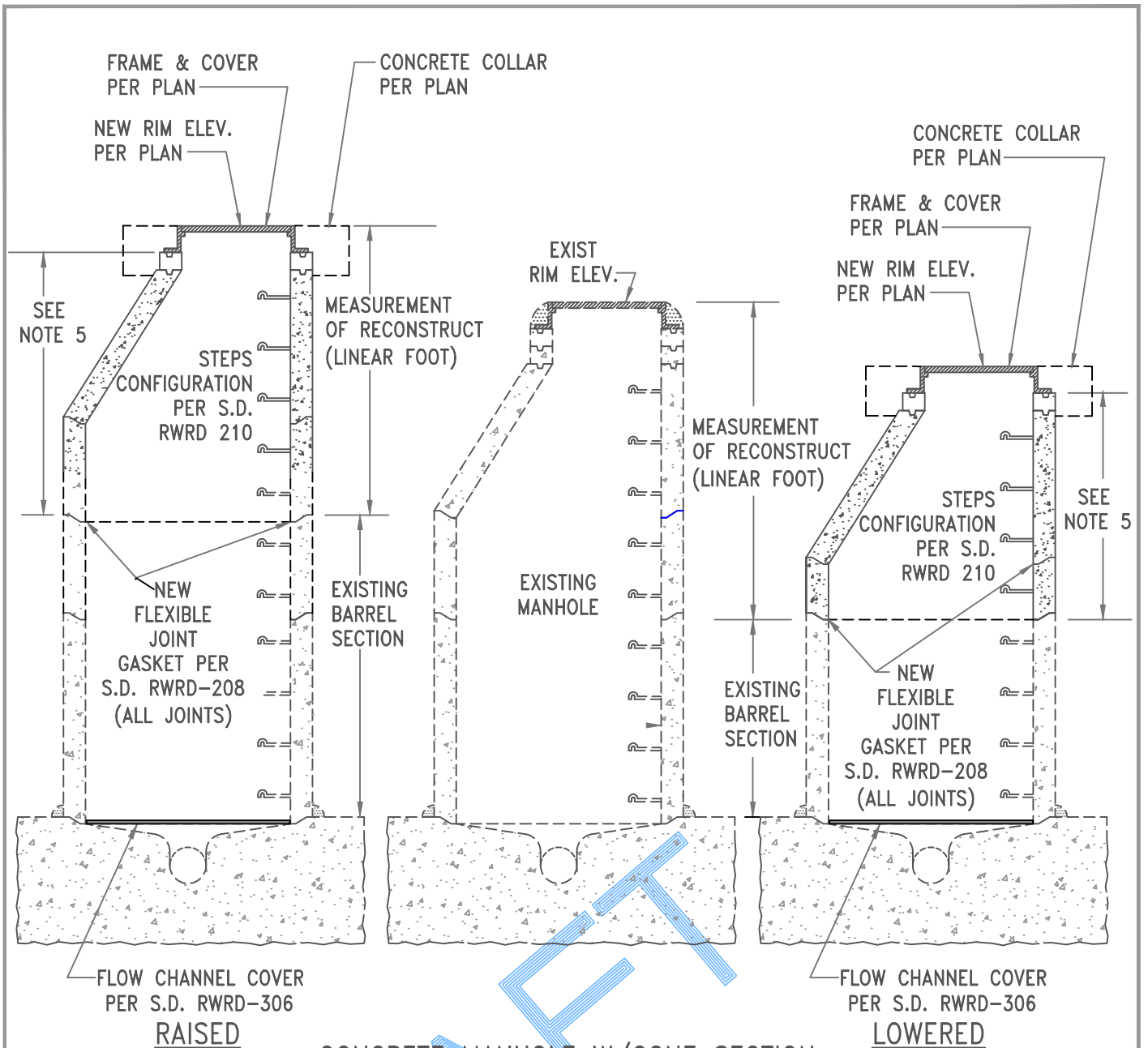

CONCRETE MANHOLE W/CONE SECTION
N.T.S.

NOTES:

1. PRECAST CONCRETE MANHOLE SECTIONS SHALL CONFORM TO ASTM C478 AND AASHTO M199.
2. ONLY NEW MANHOLE COMPONENTS SHALL BE USED.
3. SEE SUBSECTIONS 3.3.2(E) AND 3.3.3 FOR MORE INFORMATION.
4. RECONSTRUCTION OF AN EXISTING MANHOLE SHALL BE REQUIRED FOR VIOLATION OF THE DIMENSIONAL RANGES NOTED IN STANDARD DETAILS RWRD 304 AND RWRD 305 AND TYPICALLY WHEN THE ADJUSTMENT IN RIM ELEVATION EXCEEDS 12 INCHES.
5. PRECAST CONCRETE GRADE RING(S) AND PRECAST CONCRETE CONE AND BARREL AS NEEDED PER S.D. RWRD 205 OR RWRD 206.

ISSUED:	STANDARD DETAIL		DETAIL NO.
02/21	MANHOLE RECONSTRUCTION		RWRD 309
REVISED:			SHEET 1 OF 3

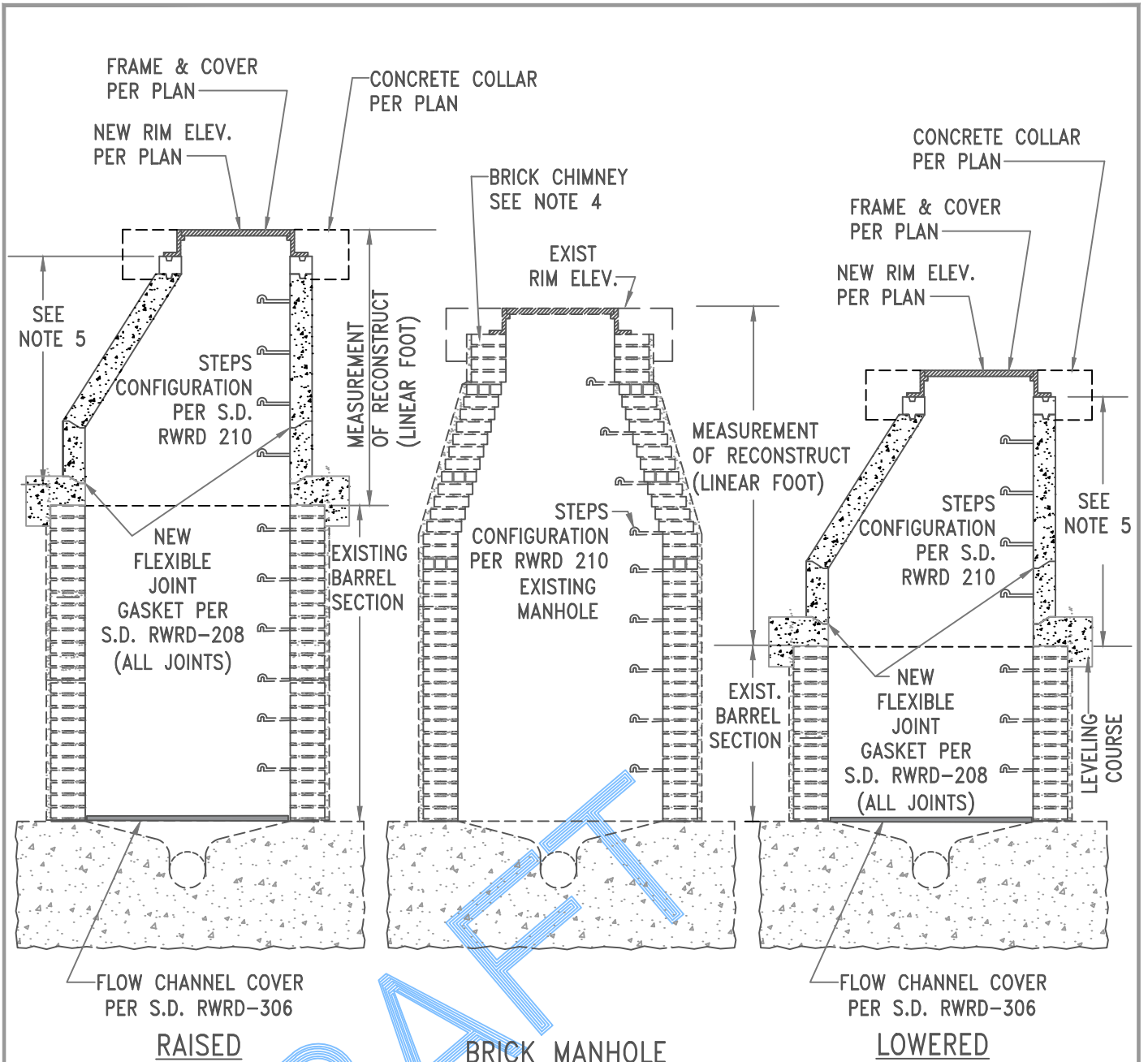

RAISED

BRICK MANHOLE

LOWERED

NOTES:

1. PRECAST CONCRETE MANHOLE SECTIONS SHALL CONFORM TO ASTM C478 AND AASHTO M199.
2. ONLY NEW MANHOLE COMPONENTS SHALL BE USED.
3. SEE SUBSECTIONS 3.3.2(E) AND 3.3.3 FOR MORE INFORMATION.
4. RECONSTRUCTION OF AN EXISTING MANHOLE SHALL BE REQUIRED FOR VIOLATION OF THE DIMENSIONAL RANGES NOTED IN STANDARD DETAILS RWRD 304 AND RWRD 305 AND TYPICALLY WHEN THE ADJUSTMENT IN RIM ELEVATION EXCEEDS 12 INCHES.
5. PRECAST CONCRETE GRADE RING(S) AND PRECAST CONCRETE CONE AND BARREL AS NEEDED PER S.D. RWRD 205 OR RWRD 206.

ISSUED:	STANDARD DETAIL		DETAIL NO.
02/21	MANHOLE RECONSTRUCTION	PIMA COUNTY WASTEWATER RECLAMATION	RWRD 309
REVISED:			SHEET 2 OF 3

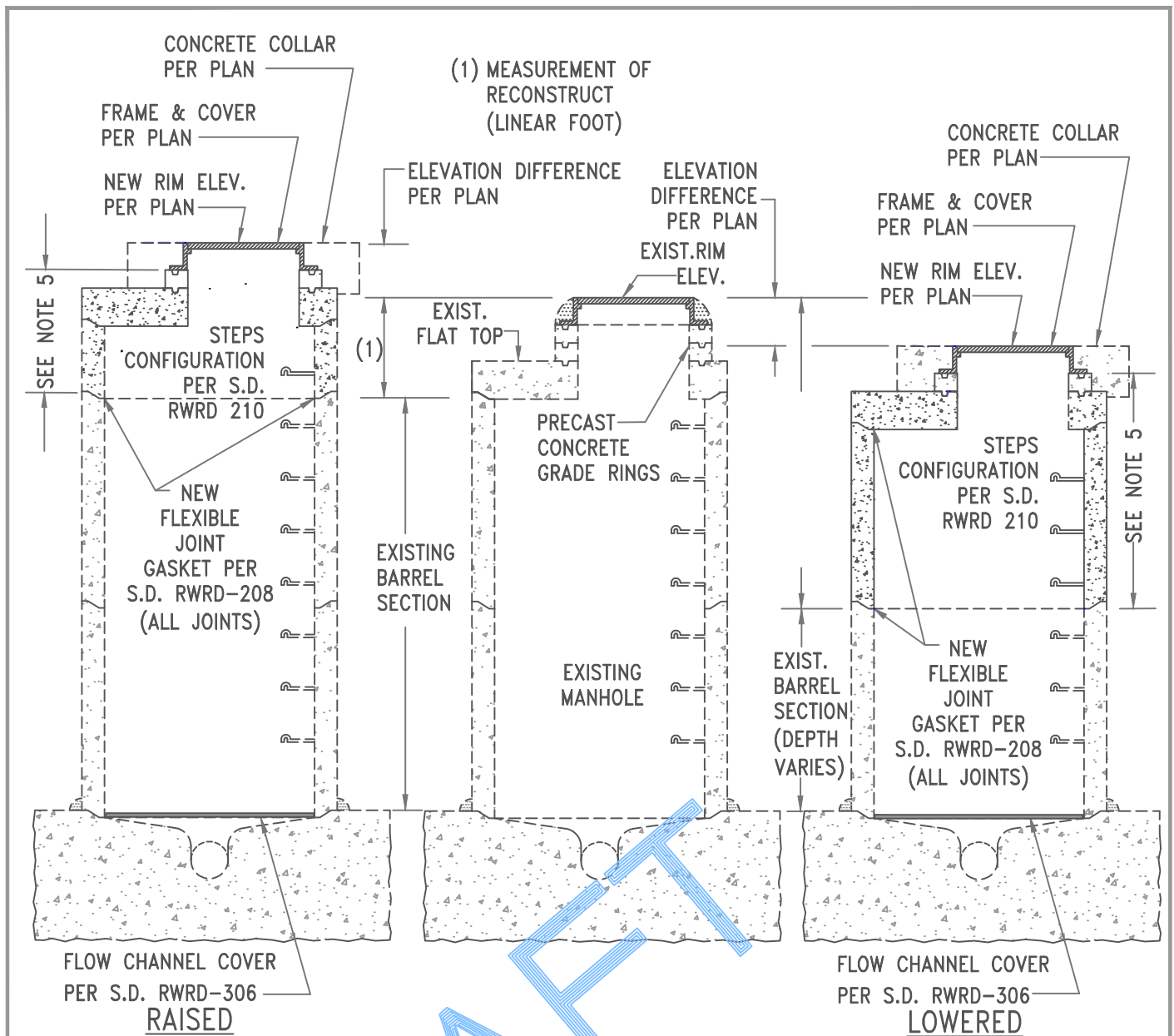

CONCRETE MANHOLE W/ FLAT TOP MANHOLE
N.T.S.

NOTES:

1. PRECAST CONCRETE MANHOLE SECTIONS SHALL CONFORM TO ASTM C478 AND AASHTO M199.
2. ONLY NEW MANHOLE COMPONENTS SHALL BE USED.
3. SEE SUBSECTIONS 3.3.2(E) AND 3.3.3 FOR MORE INFORMATION.
4. RECONSTRUCTION OF AN EXISTING MANHOLE SHALL BE REQUIRED FOR VIOLATION OF THE DIMENSIONAL RANGES NOTED IN STANDARD DETAILS RWRD 304 AND RWRD 305 AND TYPICALLY WHEN THE ADJUSTMENT IN RIM ELEVATION EXCEEDS 12 INCHES.
5. PRECAST CONCRETE GRADE RING(S) AND PRECAST CONCRETE BARREL AS NEEDED PER S.D. RWRD 205 OR RWRD 206.

ISSUED:	STANDARD DETAIL		DETAIL NO.
02/21	MANHOLE RECONSTRUCTION		RWRD 309
REVISED:			SHEET 3 OF 3

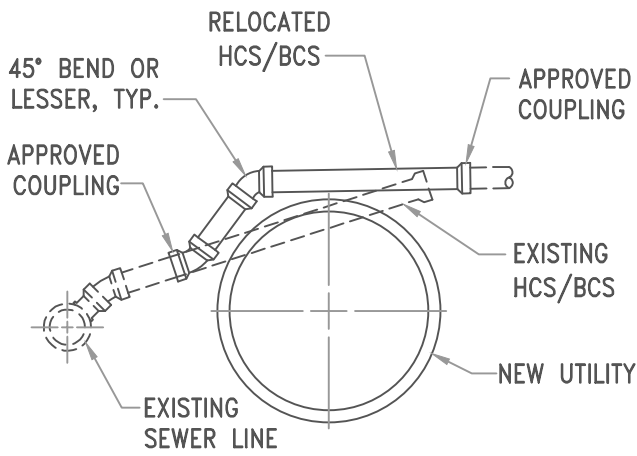

CASE "A"
N.T.S.

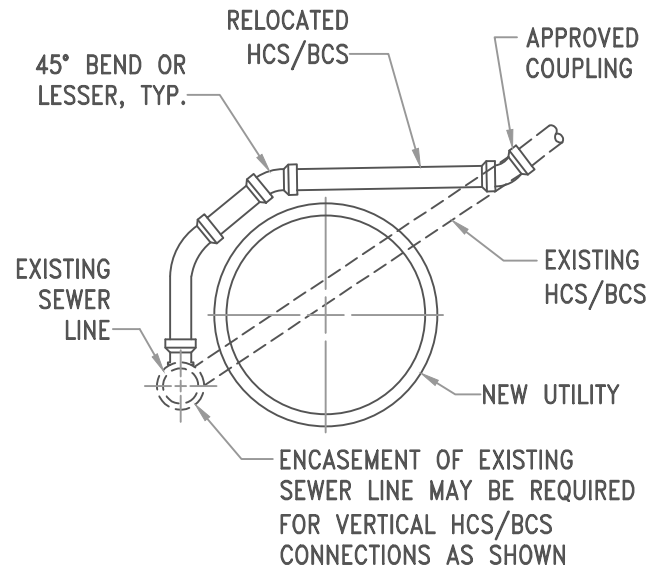

CASE "B"
N.T.S.

DRAFT

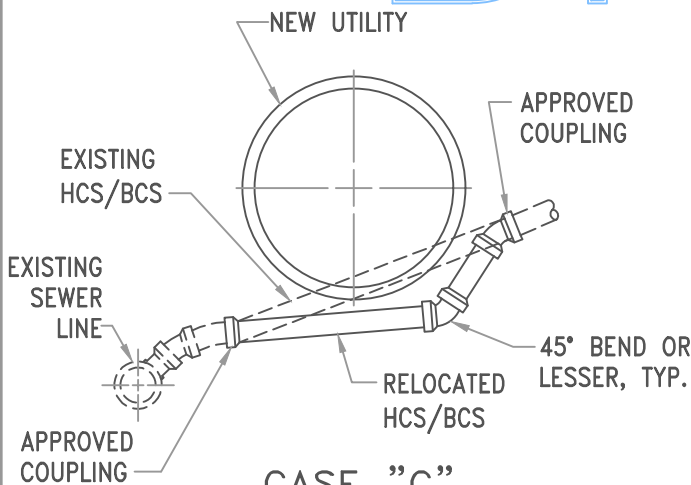

CASE "C"
N.T.S.

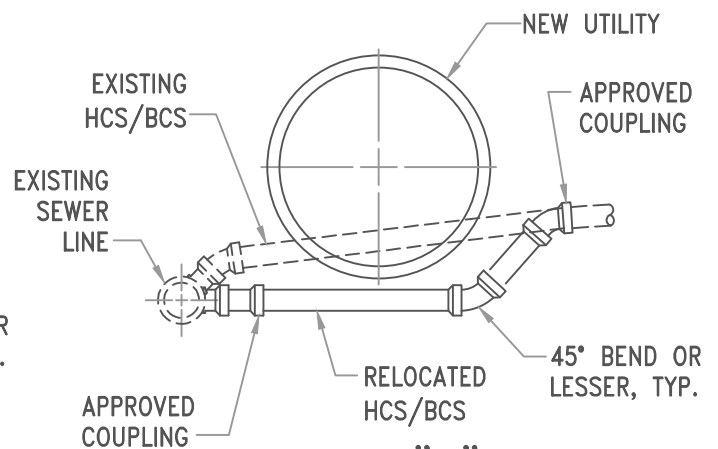

CASE "D"
N.T.S.

NOTES:

1. THE MATERIAL OF THE RELOCATED SERVICE LATERAL (HCS/BCS) SHALL BE PVC EXCEPT WHERE THERE IS LESS THAN 12" OF CLEARANCE BETWEEN THE NEW UTILITY OR LESS THAN 3' OF COVER TO FINISHED GRADE. IN SUCH CASES, THE PIPE MATERIAL LOCATED WITHIN THE RIGHT OF WAY, SHALL BE DIP.
2. USE OF CASE "D" TYPE REROUTING DEPENDS ON THE LEVEL OF FLOW (PRESENT AND FUTURE) WITHIN PUBLIC SEWER AND IS SUBJECT TO CASE-BY-CASE APPROVAL BY THE FIELD ENGINEER.
3. THE MINIMUM SLOPE ON ANY REROUTED SERVICE LATERAL SHALL BE 1.00%.

ISSUED:	STANDARD DETAIL		DETAIL NO.
8/92 (WWM-404)			RWRD 400
REVISED:	HCS REROUTING		SHEET 1 OF 1
12/12			

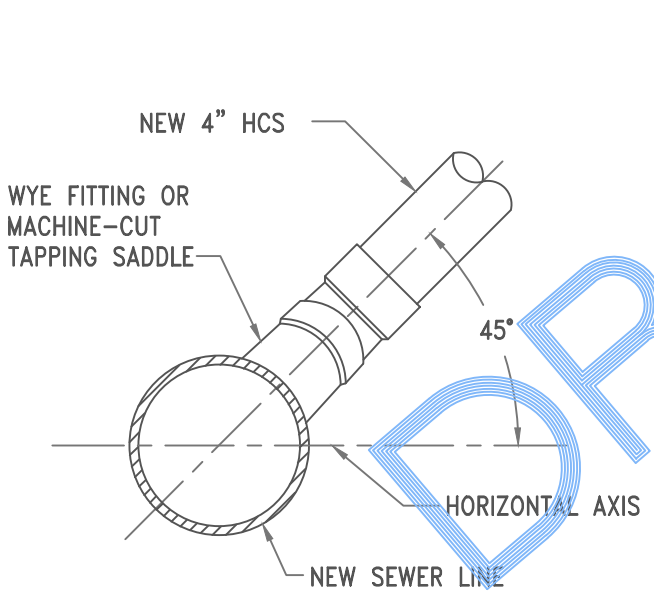
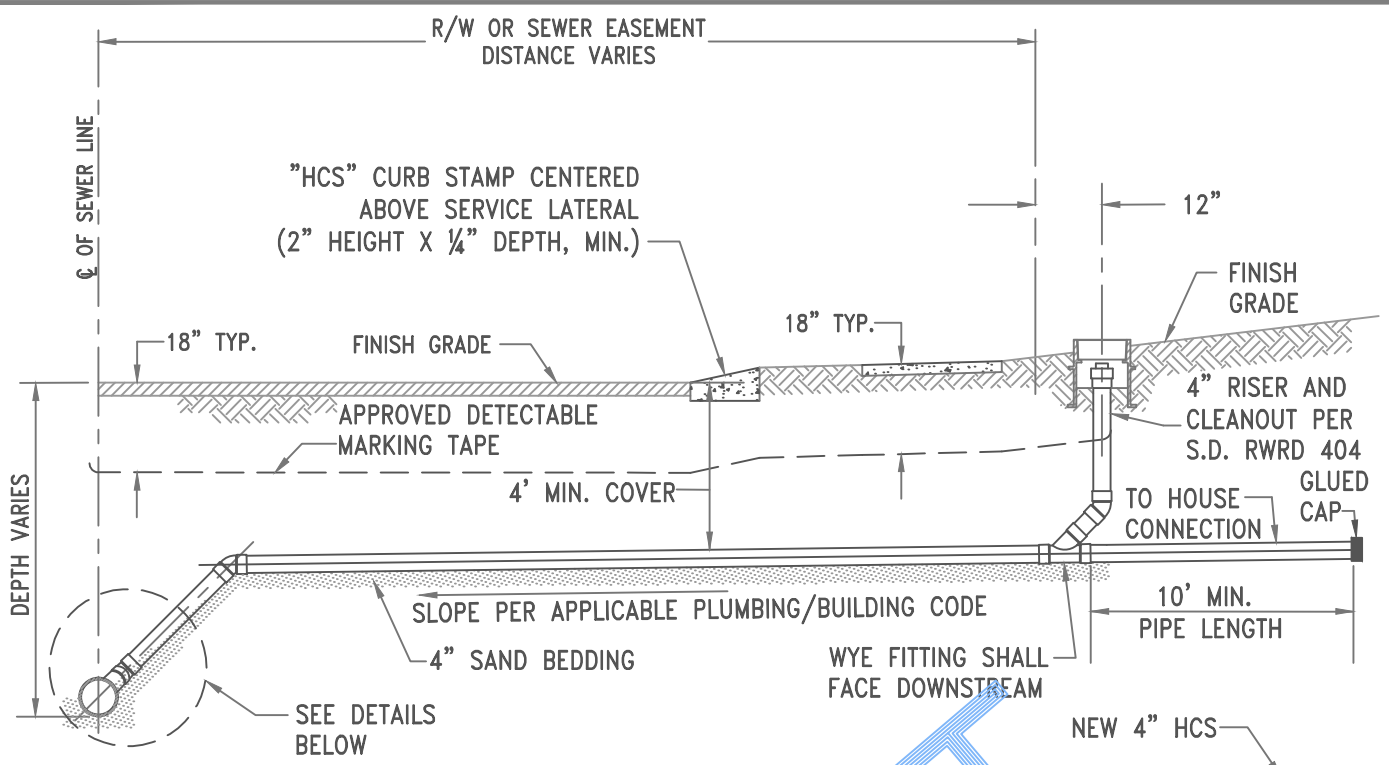

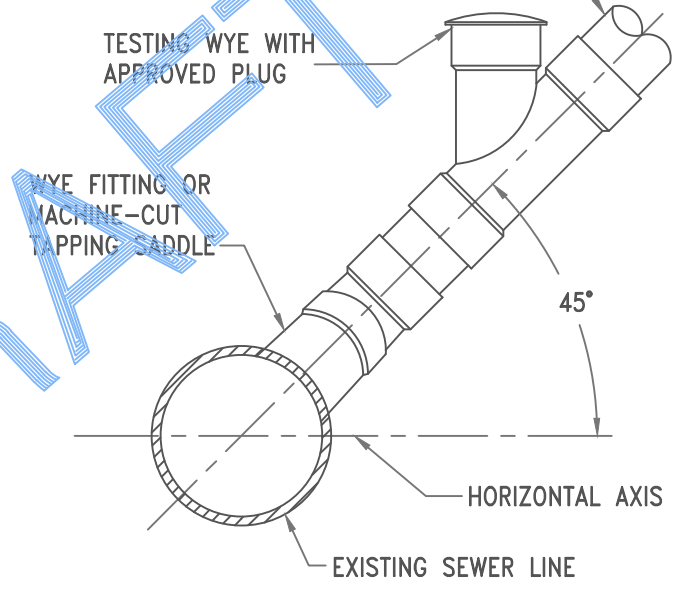

**HCS CONNECTION TO
NEW SEWER LINE**
N.T.S.



**HCS CONNECTION TO
EXISTING SEWER LINE**
N.T.S.

NOTE:
INSTALLATION OF FITTINGS AND TAPPING SADDLES SHALL CONFORM TO THE PIPE MANUFACTURER'S RECOMMENDATIONS AND SUBSECTION 3.2.3(C).

ISSUED:	STANDARD DETAIL		DETAIL NO.
8/92			RWRD 401
REVISED:	HCS CONNECTION TO SEWER LINE		SHEET 1 OF 1
02/21			

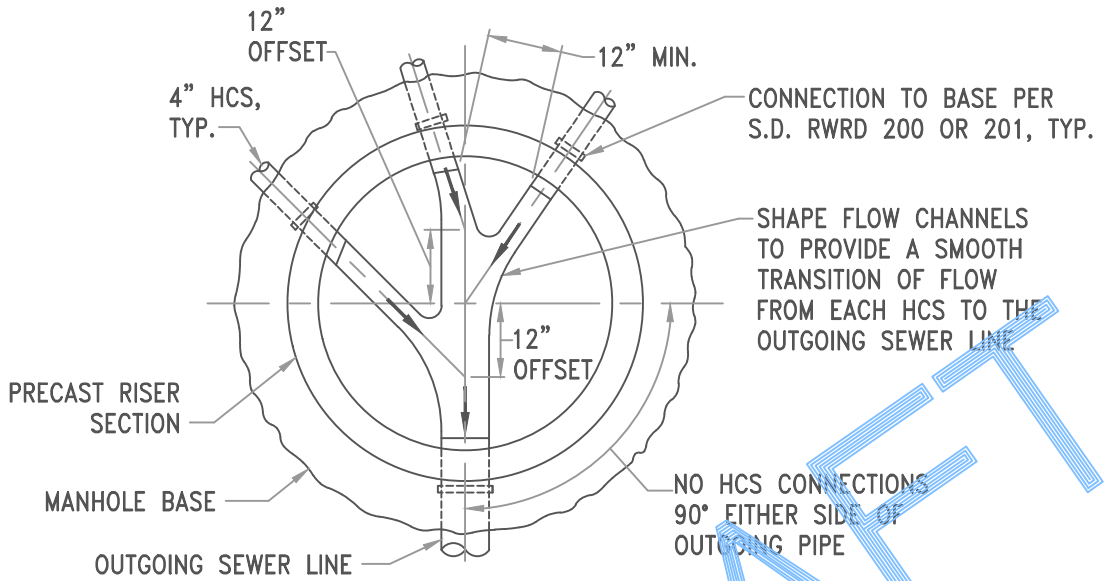

PLAN VIEW
 (TERMINAL MANHOLE IN CUL-DE-SAC)
 N.T.S.

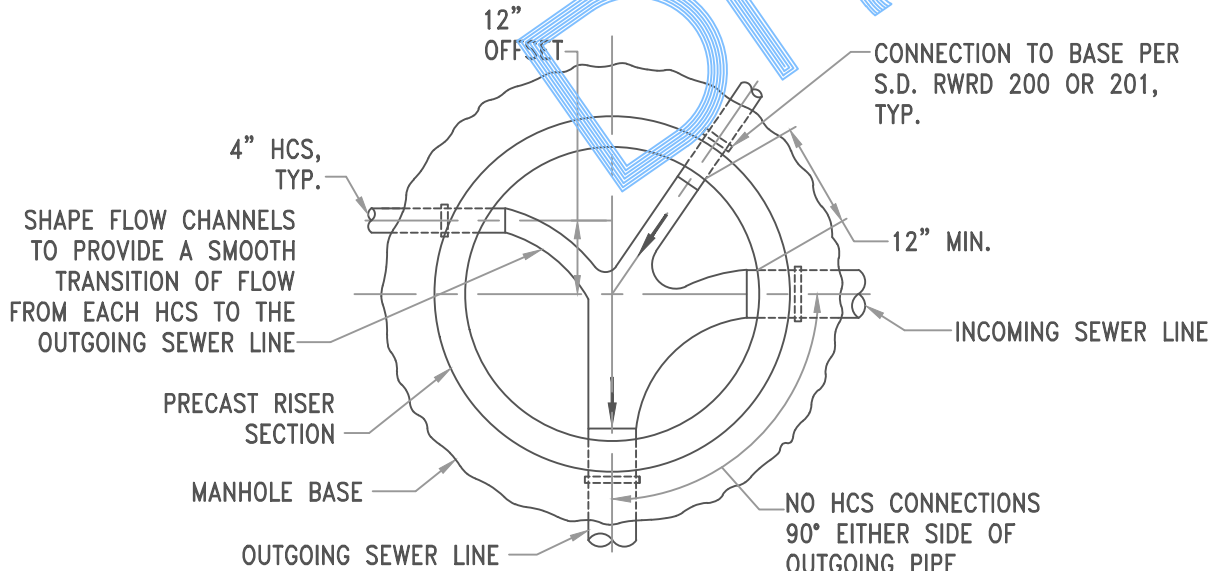

PLAN VIEW
 (90° MANHOLE IN KNUCKLE INTERSECTION)
 N.T.S.

NOTES:

1. THIS STANDARD DETAIL MAY ONLY BE USED IN ACCORDANCE WITH SEC. 5.3.2, EDS, OR IF APPROVED IN WRITING.
2. THE CROWN ELEVATION OF EACH HCS SHALL MATCH THE CROWN ELEVATION OF THE OUTGOING SEWER LINE.

ISSUED:	STANDARD DETAIL		DETAIL NO.
8/92	HCS CONNECTIONS TO MANHOLES		RWRD 402
REVISED:			SHEET 1 OF 1
02/21			

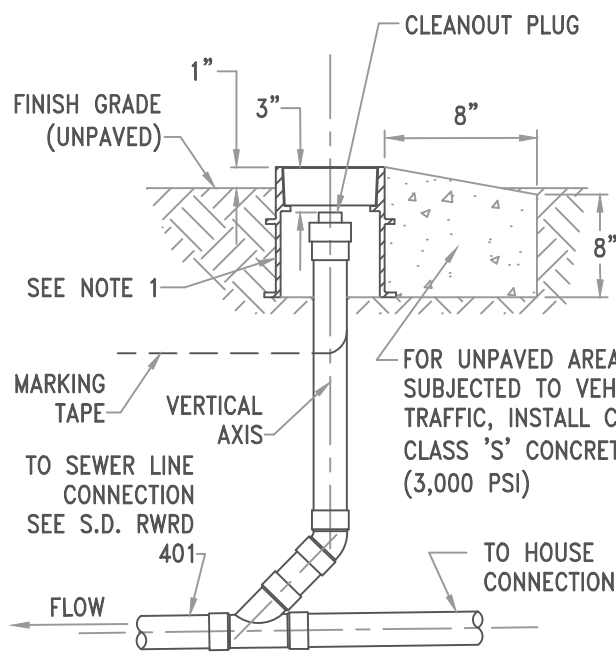

TYPE I

FINAL INSTALLATION FOR DEVELOPED LOTS IN UNPAVED AREAS
N.T.S.

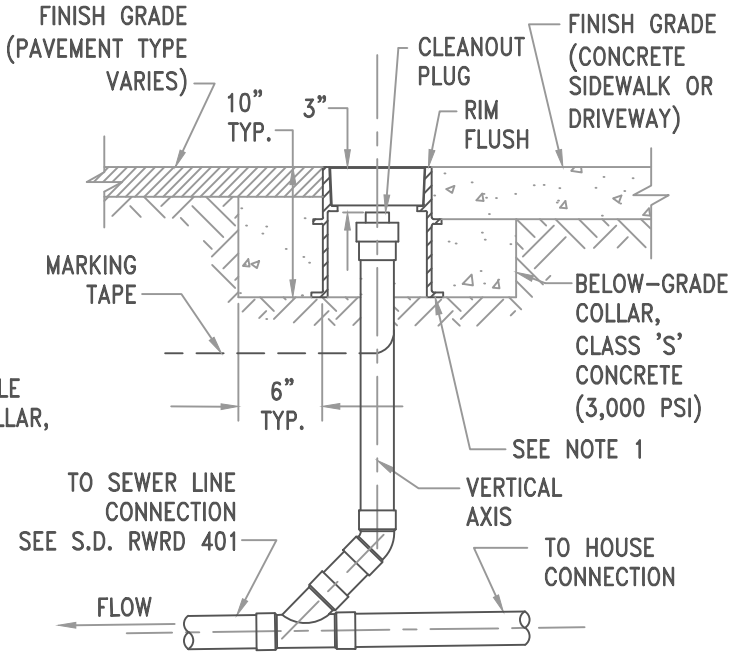

TYPE II

FINAL INSTALLATION IN PAVED AREAS
N.T.S.

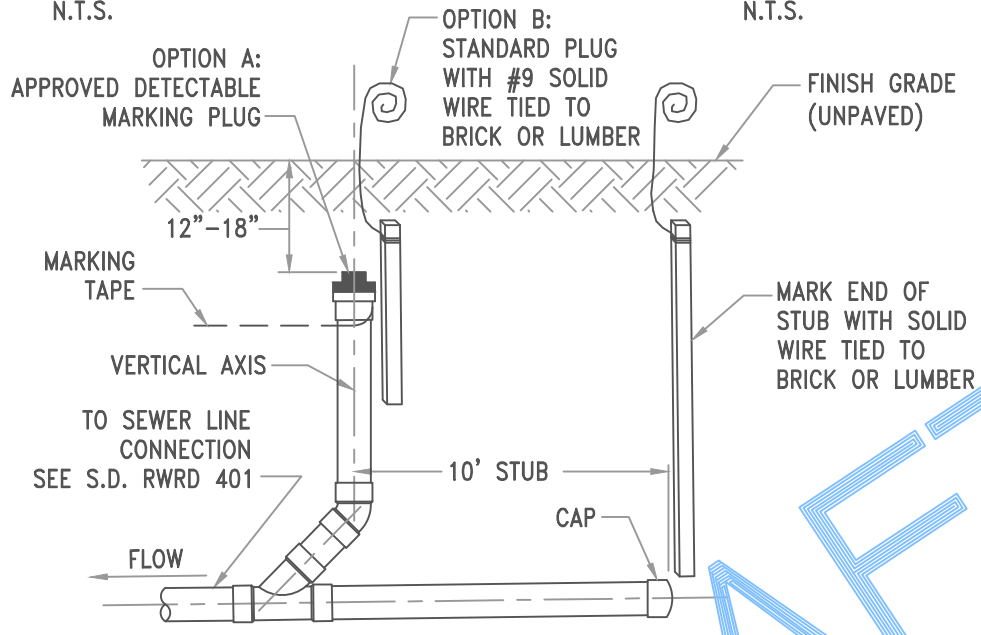

TYPE III

FINAL INSTALLATION FOR UNDEVELOPED LOTS IN UNPAVED AREAS (SEE NOTE 2)
N.T.S.

NOTES

1. BOX AND COVER PER TUCSON WATER DETAIL SD-300 WITH MODIFIED COVER LABELED "SEWER" UNLESS OTHERWISE APPROVED BY THE FIELD ENGINEER.
2. A COMPLETED MEMORANDUM OF UNDERSTANDING FORM IS REQUIRED TO IDENTIFY OPTION A OR OPTION B FOR TYPE III CLEANOUT RISER INSTALLATIONS. CONTACT THE FIELD ENGINEER FOR THE CURRENT VERSION.
3. SEE SUBSECTION 3.2.3(C) FOR MORE INFORMATION.

ISSUED:	STANDARD DETAIL		DETAIL NO.
12/12			RWRD 404
REVISED:			
10/15			
HCS CLEANOUTS			

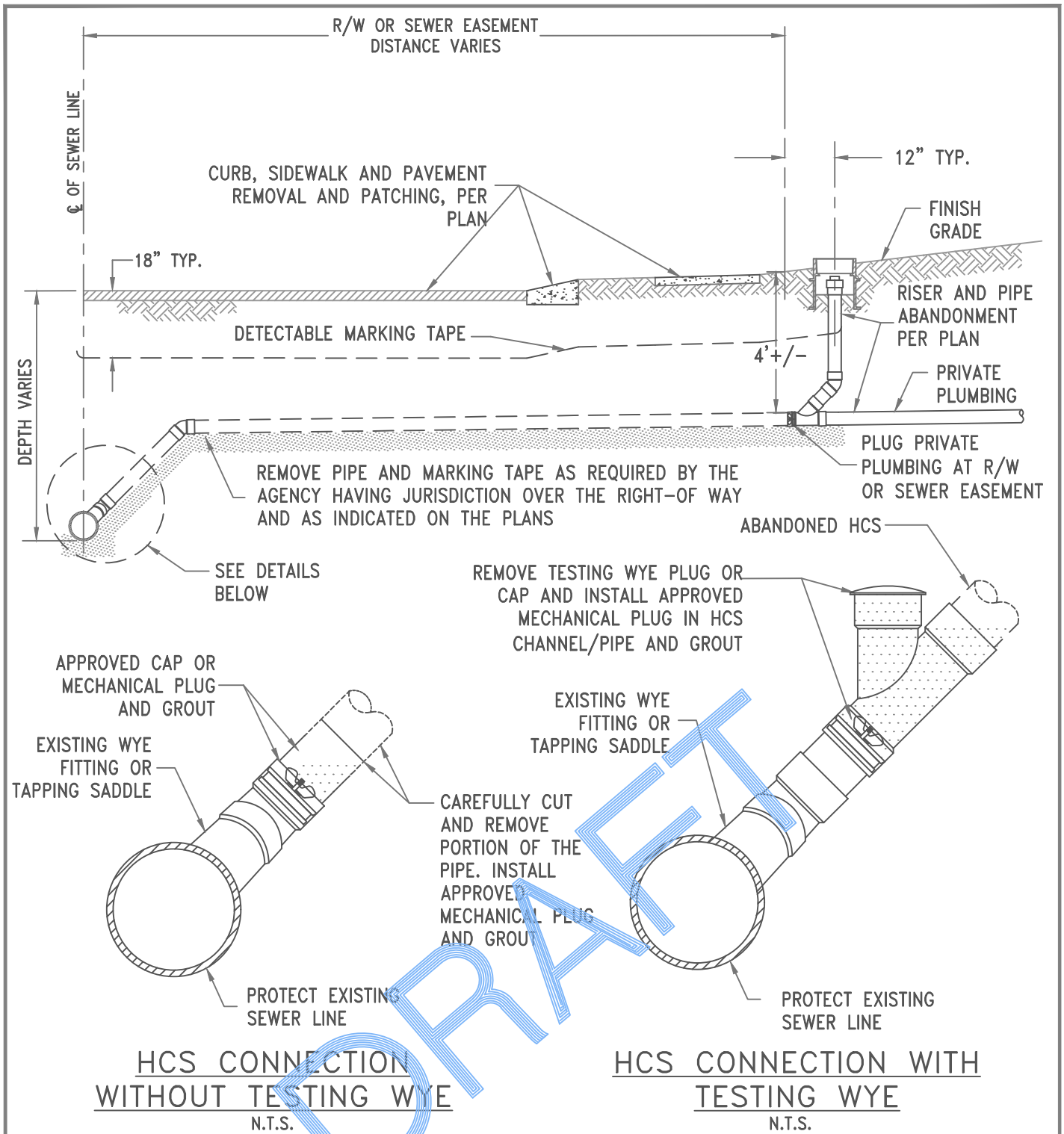

NOTES:

1. CONTRACTOR TO USE PRECAUTION WHEN CUTTING THE PIPE. AVOID ANY MATERIAL FROM ENTERING THE SEWER SYSTEM.
2. CUT AND PLUG HCS AS CLOSE AS POSSIBLE TO THE EXISTING SEWER MAIN.

ISSUED:	STANDARD DETAIL		DETAIL NO.
02/21	HCS ABANDONMENT		RWRD 405
REVISED:			SHEET 1 OF 1

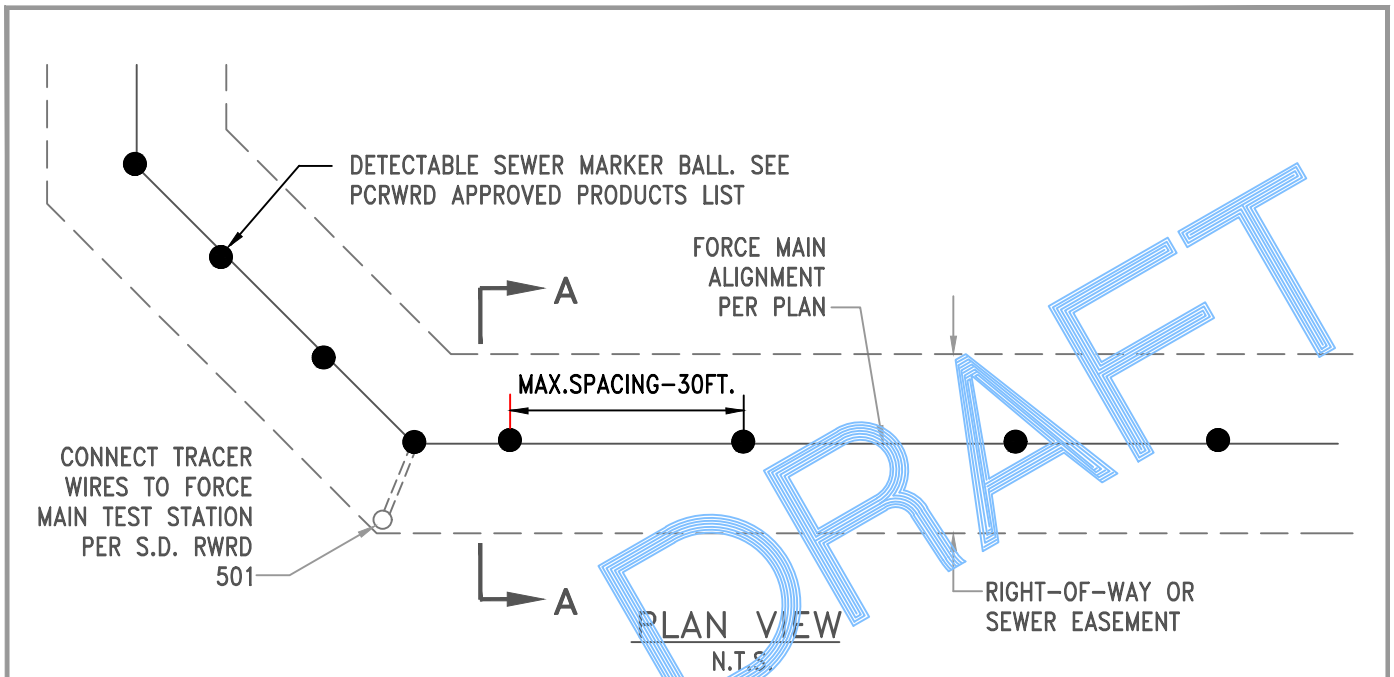

DRAFT

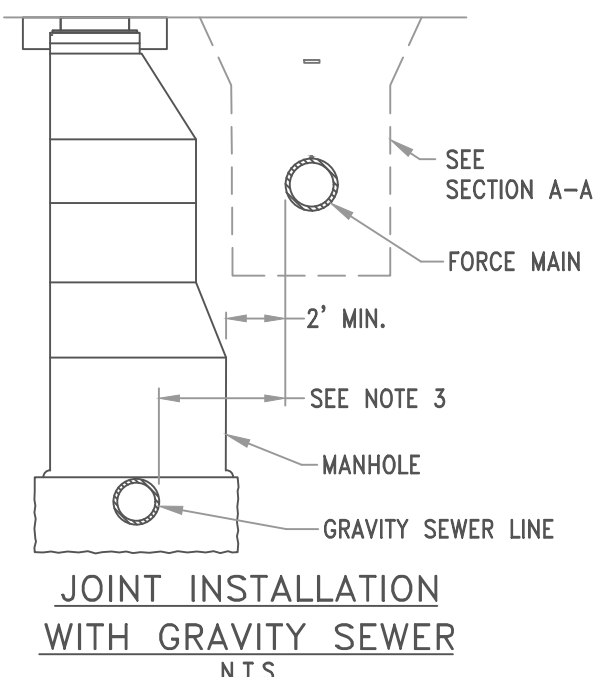
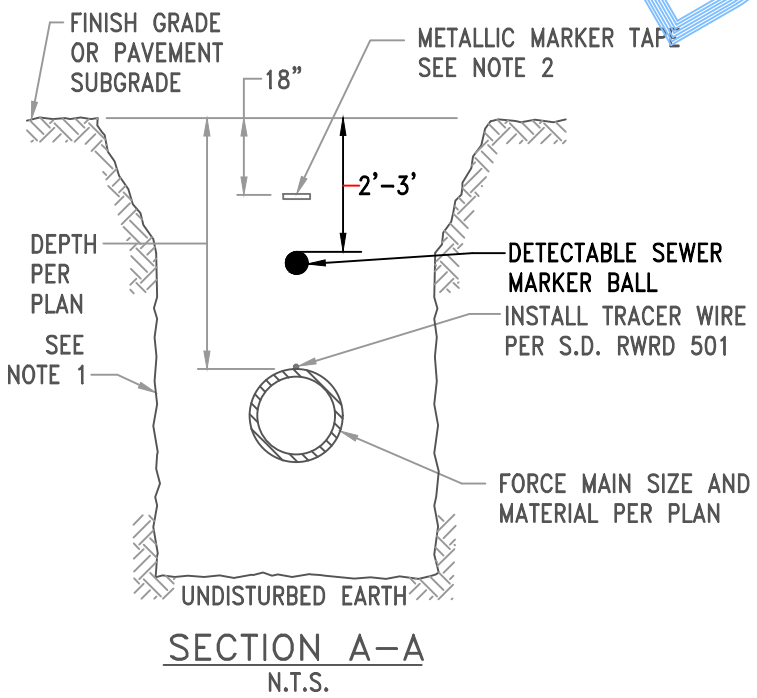

NOTES:

1. TYPICAL TRENCH FOR FORCE MAINS SHALL CONFORM TO THE FLEXIBLE PIPE TRENCH REQUIREMENTS IN S.D. RWRD 104 WITH THE ADDITIONAL MODIFICATIONS AS SHOWN.
2. CONTINUOUS PRINTING ON MARKER TAPE SHALL STATE "CAUTION: SEWAGE FORCE MAIN" UNLESS OTHERWISE APPROVED BY THE FIELD ENGINEER.
3. FOR JOINT INSTALLATIONS WITH GRAVITY SEWER, THE MINIMUM HORIZONTAL CLEARANCE BETWEEN THE FORCE MAIN AND GRAVITY SEWER LINE SHALL NOT RESULT IN HORIZONTAL JOGGING OF THE FORCE MAIN AROUND MANHOLES.
4. SEE SUBSECTION SSDC 3.2.3(B)(v) FOR MORE INFORMATION.

ISSUED:	STANDARD DETAIL		DETAIL NO.
8/92 (WWM-504)	TYPICAL TRENCH FOR FORCE MAINS		RWRD 500
REVISED:			SHEET 1 OF 1
09/21			

ARCWELD 1-1/2" LETTERING
ONTO CAST IRON COVER
"PCRWRD TEST STATION"

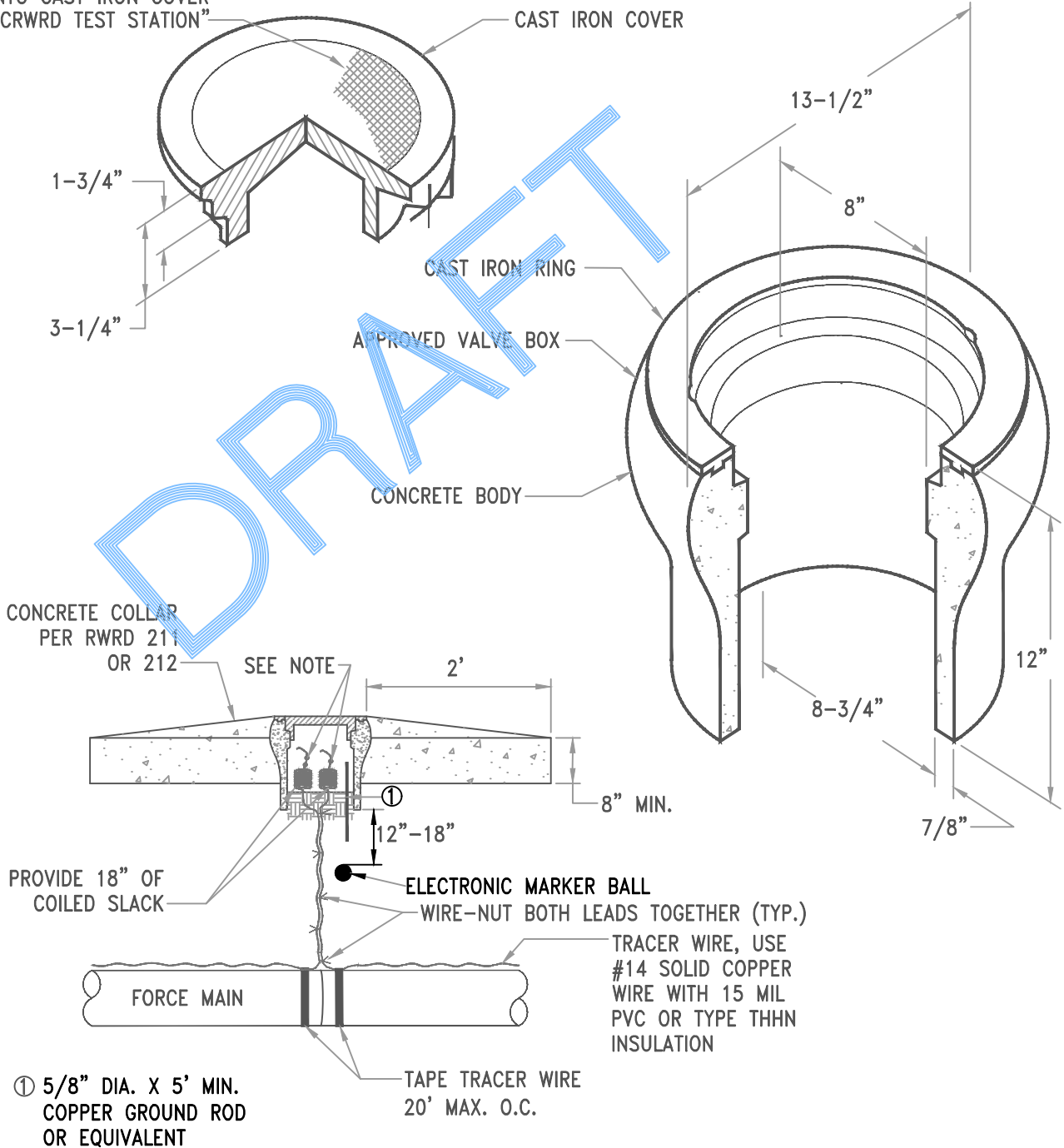

① 5/8" DIA. X 5' MIN.
COPPER GROUND ROD
OR EQUIVALENT

NOTES:

1. KNOTS SHALL BE PROVIDED APPROXIMATELY 6" FROM THE END OF LEAD AND AS SUCH:
 - ANODE LEAD TO HAVE 2 KNOTS;
 - TRACER WIRE RUNNING NORTHERLY OR EASTERLY TO HAVE ONE KNOT;
 - TRACER WIRE RUNNING SOUTHERLY OR WESTERLY TO HAVE NO KNOTS.
2. MAXIMUM SEPARATION BETWEEN TEST STATIONS SHALL BE 1,000 FEET.

ISSUED:	STANDARD DETAIL		DETAIL NO.
8/92 (WWM-511)	FORCE MAIN TEST STATION		RWRD 501
REVISED:			SHEET 1 OF 1
08/21			

FOR FORCE MAIN DIA. $<6"$, $\theta \leq 90^\circ$
 FOR FORCE MAIN DIA. $\geq 6"$, $\theta \leq 45^\circ$

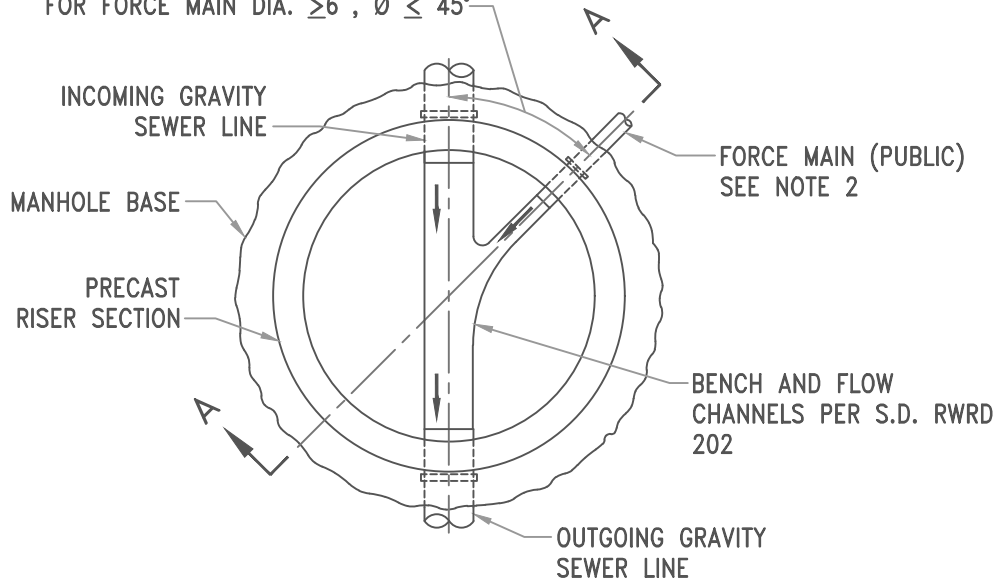

PLAN VIEW
N.T.S.

DRAFT

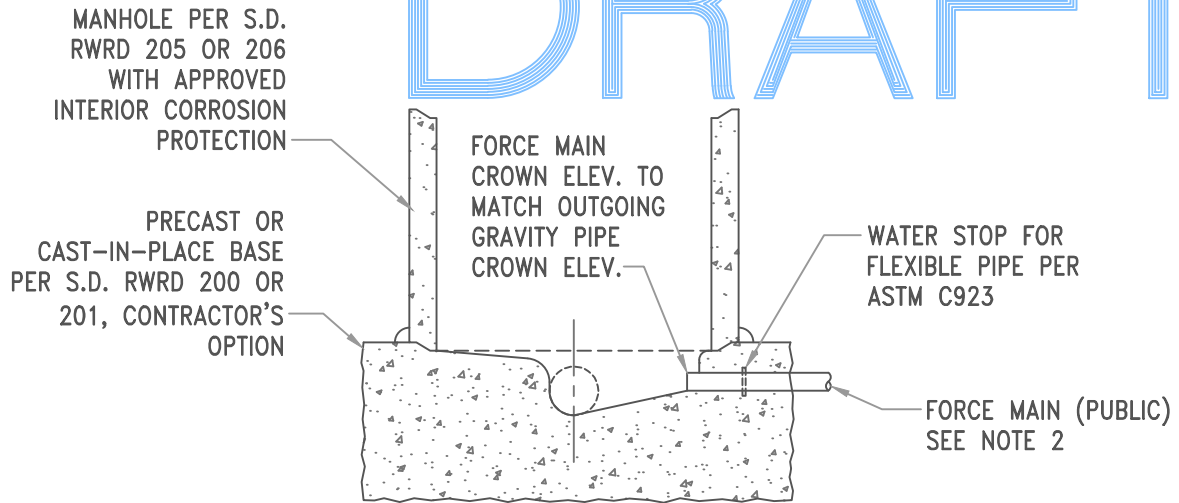

SECTION A-A
N.T.S.

NOTES:

1. FOR TERMINAL MANHOLES, CONNECT THE FORCE MAIN IN THE SAME HORIZONTAL ALIGNMENT AS THE OUTGOING GRAVITY SEWER LINE.
2. THE CONNECTION OF A PRIVATE FORCE MAIN INTO A PUBLIC MANHOLE IS NOT PERMITTED. PRIVATE FORCE MAINS SHALL DISCHARGE INTO A PRIVATE MANHOLE, LOCATED ON PRIVATE PROPERTY. THE PRIVATE MANHOLE SHALL CONNECT TO A DOWNSTREAM PUBLIC MANHOLE WITH A PRIVATE GRAVITY SEWER LINE.

ISSUED:	STANDARD DETAIL FORCE MAIN CONNECTION TO MANHOLE	 PIMA COUNTY WASTEWATER RECLAMATION	DETAIL NO.
8/92 (WWM-505)			RWRD 502
REVISED:			SHEET 1 OF 1
10/15			

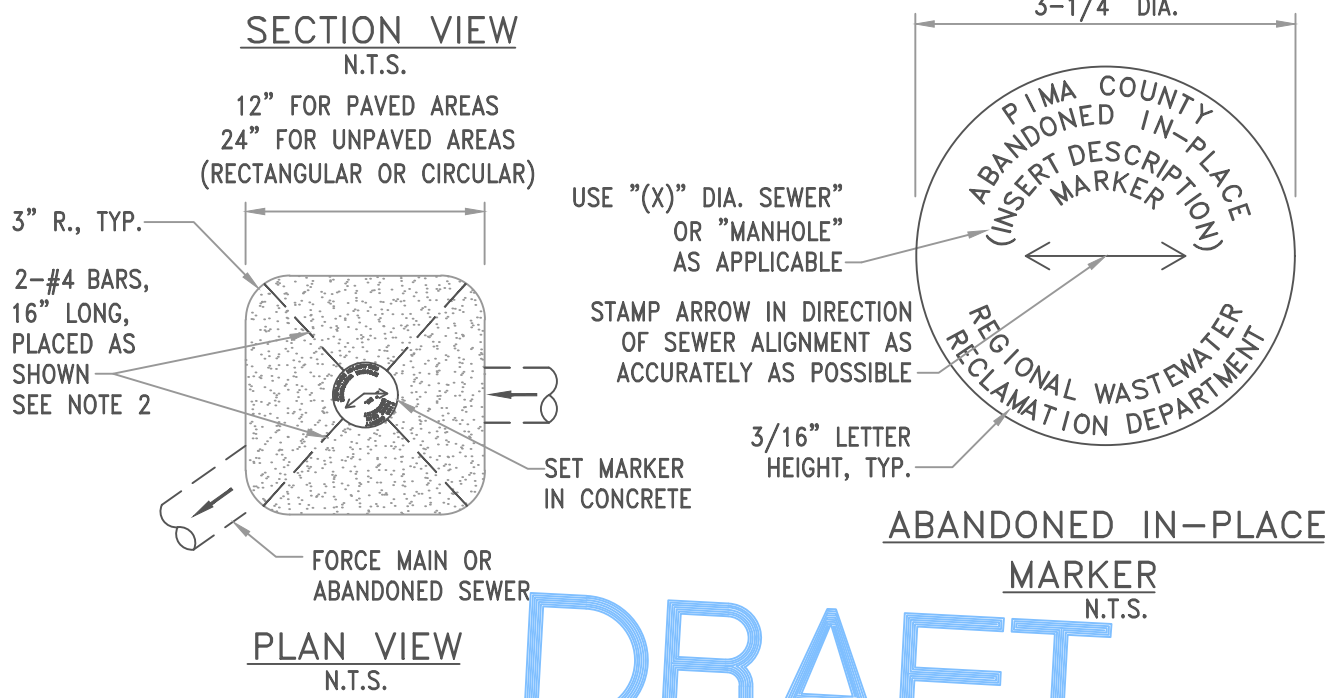
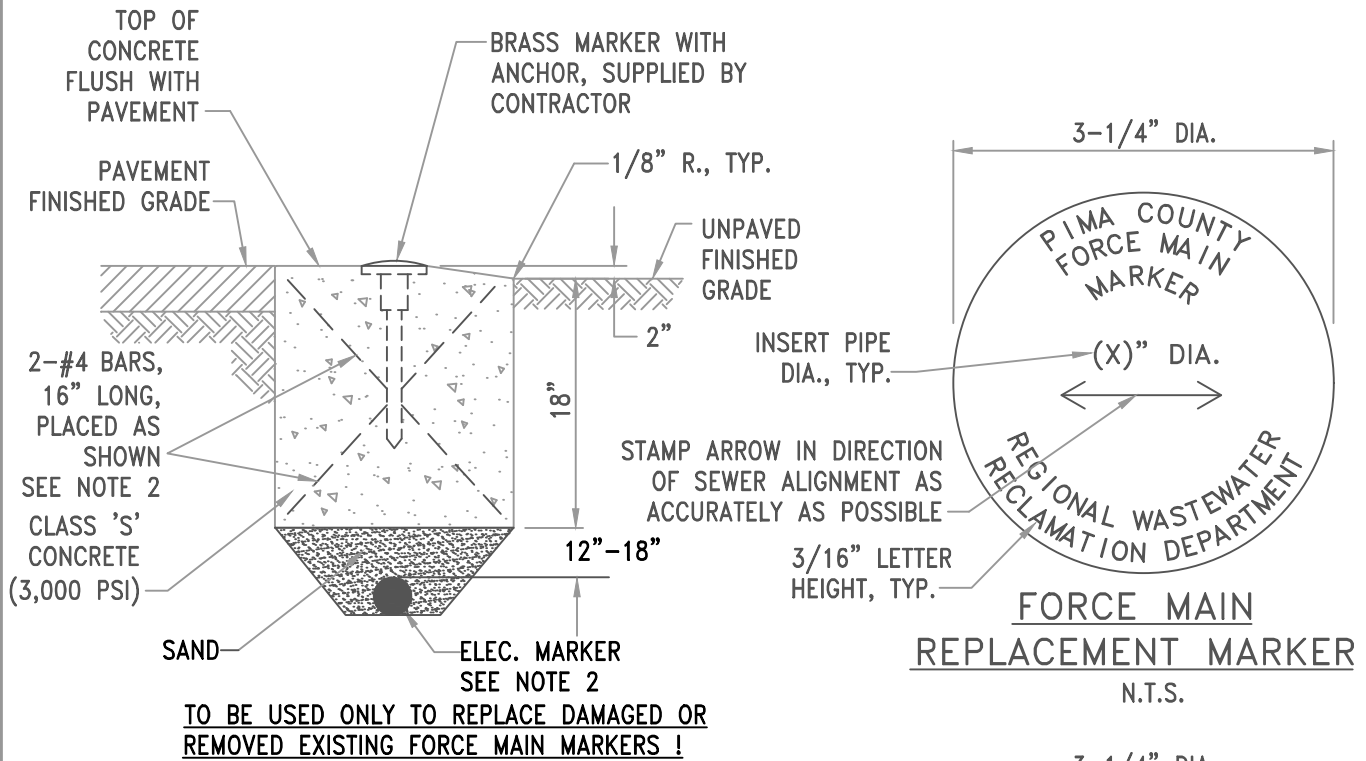

DRAFT

NOTES:

1. MARKER DATA SHALL BE AS SHOWN, WITH THE EXCEPTION OF THE NOTATION IN PARENTHESIS TO BE MODIFIED AS NOTED.
2. FORCE MAIN REPLACEMENT MARKER- REINFORCING BARS MAY BE DELETED WITH THE INSTALLATION OF AN APPROVED ELECTRONIC MARKER BALL PLACED BELOW THE BASE OF THE MONUMENT, AS SHOWN.
3. ABANDONMENT MARKERS SHALL BE PLACED AT THE TERMINAL ENDS OF ABANDONED SEWER LINES/FORCE MAINS WITH A MAXIMUM SPACING OF 500 FEET AND CENTERED ABOVE ABANDONED MANHOLES.
4. SEE S.S.D.C SECTION 1.4.7.M FOR RECORD DRAWING MARKER ANNOTATION REQUIREMENTS.

ISSUED:	STANDARD DETAIL		DETAIL NO.
8/92 (WWW-507/508)	FORCE MAIN ABANDONMENT AND REPLACEMENT MARKERS		RWRD 503
REVISED:			
11/21			SHEET 1 OF 1

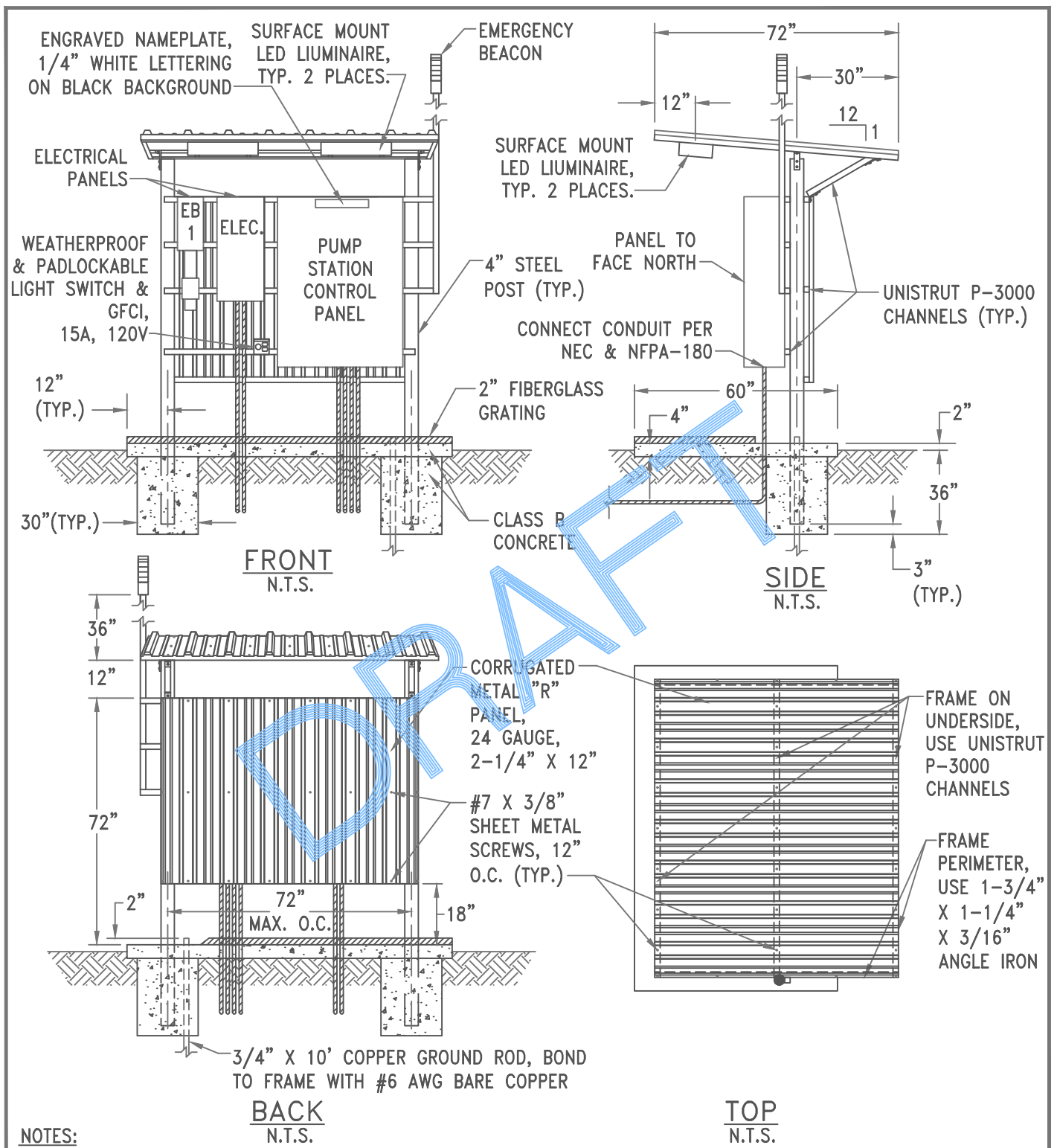

NOTES:

1. PAINT EXPOSED METAL WITH #1 ALKYD PRIMER & #2 ALKYD WHITE (1 COAT EA.) PER 2015 PAG STD. SPEC. 1002.
2. EQUIPMENT MAY BE RECONFIGURED TO MEET JURISDICTIONAL AGENCY AND MANUFACTURER'S REQUIREMENTS. INSTALL ADDITIONAL SUPPORT POST(S) AS NEEDED AT 72" MAX. O.C. FOR ADDITIONAL PANEL WIDTH.
3. CABINETS SHALL CONFORM TO THE FOLLOWING REQUIREMENTS: UL LISTED, NEC COMPLIANT, DEAD FRONT SAFETY TYPE, COPPER BUS BARS WITH FULL NEUTRAL, STEEL CABINET WITHOUT KNOCKOUTS AND PADLOCKABLE.

ISSUED:	STANDARD DETAIL		DETAIL NO.
8/92 (WWM-510)			RWRD 504
REVISED:			SHEET 1 OF 1
02/21			
EQUIPMENT SUPPORT AND SHADE STRUCTURE			