

Description	Qty	Unit	Unit Price	LABOR	Unit Price	MATERIAL	Rate	Equip.	SUB CONT.	TOTAL
Trenching										
106' x 3' x 2.5' x 1.1 / 27	32.38	CY								
Trenching @ 4 CY/HR	8.09	HRS	2.000	633.12			33.00	266.97		900.09
GLT @ 100' @ HR	1.06	HRS	2.000	82.96			15.00	15.90		98.86
Backfill @ 6 CY/ HR	5.39	HRS	2.000	421.82			33.00	177.87		599.69
Concrete Encased										
230' x 1' x 2.5' x 1.1 / 27	32.38	CY	0.200	253.41	100.000	3,238.00				3,491.41
Exterior Lighting at Bldg 20										
Pole Light	2	EA	6.000	469.56	E/W		89.50	358.00		827.56
Auger 24" x 6' Deep	2	EA	2.000	156.52	N/A		49.50	198.00		354.52
Rebar Cage 24" x 8' Deep	2	EA	2.000	156.52	E/W		49.50	99.00		255.52
Sonotube 24" D x 4'	2	EA	1.000	78.26	16.000	32.00				110.26
Install anchor bolts	2	SET	2.000	156.52	N/A					156.52
Concrete	2.05	CY	3.000	240.65	100.000	205.00				445.65
3/4" GRC PVC/C	400	LF	0.100	1,565.20	3.420	1,368.00				2,933.20
3/4" GRC 90 PVC/C	4	EA	0.350	54.78	12.676	50.70				105.49
3/4" GRC Coupling	8	EA	0.100	31.30	0.972	7.77				39.08
3/4" GB	2	EA	0.150	11.74	2.554	5.11				16.85
3/4" EYS	4	EA	1.000	156.52	16.346	65.38				221.90
3/4" Strut Strap SS	6	EA	0.100	23.48	4.908	29.45				52.93
3/4" Hub	1	EA	0.500	19.57	7.753	7.75				27.32
#10 XHHW	1233	LF	0.010	482.47	0.187	230.97				713.44
Label and Termination	15	EA	0.150	88.04	1.650	24.75				112.79
Trenching										
96' x 2' x 2' x 1.1 / 27	15.64	CY								
Trenching @ 4 CY/HR	3.91	HRS	2.000	306.00			33.00	129.03		435.03
GLT @ 100' @ HR	0.96	HRS	2.000	75.13			15.00	14.40		89.53
Backfill @ 6 CY/ HR	2.6	HRS	2.000	203.48			33.00	85.80		289.28
Gear Package (AES)										
	1	LS			577,000.00	577,000.00				577,000.00
Lighting Package (Graybar)										
	1	LS			12,815.00	12,815.00				12,815.00
Fire Alarm (Jonhson Controls)										
	1	LS							24,273.00	24,273.00
Security (APL)										
	1	LS							28,456.34	28,456.34

Description	Qty	Unit	Unit Price	LABOR	Unit Price	MATERIAL	Rate	Equip.	SUB CONT.	TOTAL
Lighning Protection and UL Certificate (Canfield Engineering)	1	LS							34,827.00	34,827.00
Integration of the system to Pima County (Canfield Engineering)	1	LS							118,771.00	118,771.00
PQM Integration (Canfield Engineering)	1	LS							9,840.00	9,840.00
Arc Flash (Canfield)	1	LS							11,609.00	11,609.00
Control Panel CP87B (Canfield)	1	LS							70,548.00	70,548.00
Control Panel CP19	1	LS							110,853.00	110,853.00
Third Party Testing	1	LS							5,000.00	5,000.00
Re-bar Cages and Duct Bank	1	LS							5,595.00	5,595.00
Job Truck	704	HRS					10.00	7,040.00		7,040.00
Subtotal with Electrical Man hours	7,253	Hrs		283,816.78		1,042,958.94		24,385.86	423,054.34	1,774,215.92
Man Days (8 HOUR DAY)	906.65	Days								
Foreman w/truck full time	1,056.00	HRS	\$ 54.63	57,689.28			10.00	10,560.00		68,249.28
Small Tools @ 7%	7%							19,867.17		19,867.17
Final Bid	7,253	Hrs		341,506.06		1,042,958.94		54,813.03	423,054.34	1,862,332.38
										1,862,332.38

**BioGas Cleaning and Utilization
GMP #2 - Subcontractor Breakdown**

Description of Work	Subcontractor	Cost
Masonry	Ruiz Masonry	\$36,960.00
HVAC/Plumbing	Advantage Air Mechanical	\$59,121.00
Painting/Floor Coating	A-O Painting	\$22,390.00
Drywall/Steel Studs	Valenzuela Drywall	\$30,000.00
Fence	Canyon Fence	\$7,963.00
Rebar	Tyler Reinforcing	\$6,489.00
Roofing	Progressive Roofing	\$37,252.00
Quality Control	Conformatech	\$10,545.00
Fire Alarm	Johnson Controls	\$24,273.00
Security System	APL Access and Security	\$28,456.34
Engineering Services	Canfield Engineering	\$356,448.00

Subcontractor Total \$619,897.34

GMP #2 Subtotal \$4,028,069.46

Total of Ashton Self Performed Work \$3,408,172.12



November 5, 2019

Patty Bitnar
The Ashton Company, Inc.
2727 S. Country Club Rd.
Tucson, AZ 85713
Phone: (520) 624-5500
Email: PBitnar@ashtoncoinc.com

Re: TRW – GPM2 Gas Development r2
Proposal No.: 180032.3 Delivered via E-mail

Ms. Bitnar:

On behalf of the CEI staff, I would like to thank you for inviting us to participate in the proposal process for this project. In response to your request for quotation for the above-named project, we have attached our professional engineering services proposal.

Please do not hesitate to contact me at anytime if you have questions or concerns regarding this proposal.

Sincerely,

A handwritten signature in black ink that reads 'R. Ben Canfield'. The signature is written in a cursive style with a large, stylized 'R' and 'C'.

R. Ben Canfield, P.E.
Vice President of Engineering

Attachments: Proposal

Cc: File

TABLE OF CONTENTS

Project Overview: 1
Scope of Work: 2
Assumptions, Exceptions and Clarifications: 6
Project Schedule: 7
Fee Schedule: 7

November 5, 2019

TRES RIOS GPM 2 – GAS DEVELOPMENT R2

Proposal No.: 180032.3

Project Overview:

The Ashton Company, Inc (ACI) is seeking Professional Engineering Services to for a lightning protection system (LPS), Power Quality Meter (PQM), Power Study, PLC programming, and integration of the system to Pima County for the Tres Rios GMP2 Gas Development project and PLC control panel procurement.

The LPS work consists of site visits, design drawings, specifications and coordination with the design/construction team. It is anticipated that surge protection requirements are provided in the original design drawings and It's anticipated to not be added. The design will comply with NFPA-780, with a Master Label. CEI is a certified UL Listed installer and is capable of design and registered to call for inspection of the completed system.

The PQM work entails integration of the new PQMs into the existing control network and setup within the RS Energy Metrix software.

The Power Study work consists of reviewing record documents and modeling the electrical power system in SKM with the existing model. The model will be used to analyze the existing electrical equipment and perform a device evaluation, protective device coordination and arc flash study.

PLC/HMI programming for CP87A and CP19 has been included in this proposal based on IO shown on the P&IDs and an understanding of Pima County's control system. CEI will program the PLC's and update the Wondeware/Enervista screens per Pima County Standards.

CEI shall procure PLC control panel(s) CP87B and CP19 for installation by Ashton.

This proposal is based on the 95% set of drawings.

TRES RIOS GPM 2 – GAS DEVELOPMENT R2

Proposal No.: 180032.3

Scope of Work:

Task 101 Lightning Protection Design

CEI will design a lightning protection system per NFPA 780. LPS system design shall provide for lightning protection of the new bio gas equipment and electrical building as indicated in the construction drawings “Tres Rios Water Reclamation Facility Gas Development C-431”. CEI will coordinate submittals and installation with the contractor and UL. CEI will apply for UL label, schedule site visit with UL and contractor. CEI will provide the UL label to the Pima County.

Deliverables:

- Review C-431 bio gas electrical site design documentation
- Produce site plans, installation details and specifications based on the following building plans and profiles.
- Construction Drawings and Specifications
- UL Label
- Record Drawings

Task 102 System Integration of PQMs with RS Energy Metrics

The new PQMs will be configured with the existing server, redundant Virtual Machines and OI-ABCIP communication software.

The System Integration shall include configuration of PQMs within RS Energy Metrix. Procurement and installation will be provided by others. The PQM will be setup with a time stamp from the existing system to help maintain an accurate and consistent PQM event time stamp. CEI will update the existing SEL Kepware OPC drivers to communicate between the PQMs and RS Energy Metrix.

RS Energy Metrix Thin Clients will be updated.

Deliverables:

- SEL-735 Meters (Installed by others)
- Updates to existing SEL Kepware OPC
- Update RS Energy Metrix configuration for real time data collection and trouble shooting

TRES RIOS GPM 2 – GAS DEVELOPMENT R2

Proposal No.: 180032.3

- RS Energy Metrix report configuration to PDF output
- As-Built Communications network Architecture
- Native documentation of software configuration files
- Updated IP Network configuration for security

Task 103 Power Study

CEI will execute the following tasks for the fee below:

1. Conduct a Power System/Arc Flash Analysis. The analysis shall be performed in accordance with IEEE and shall utilize the ANSI method of short circuit analysis. A SKM model of the engineer of record design shall be added to the existing Tres Rios SKM model using approved equipment submittals provided by others, site collected data, and Utility short circuit data. Evaluation of Utility and plant motor Contribution for Max and Min will be performed. When the connected bus has a Main-Tie-Main (MTM) or a double Main each power feed is evaluated.
 - a. This model requires a Max/Min Scenario of the power distribution which requires an effort to maintain (2) Scenarios, or SKM Single Line diagrams and output reports along with (2) Scenarios to handle the double Main at the MCC
 - b. ANSI Complete Fault Report
 - c. Device/Bus Evaluation for both Interrupt and Momentary
 - d. CEI shall coordinate new protective devices with existing protective devices in the SKM model as required.
 - e. Worst Case Arc Flash Evaluation Table
2. CEI shall acquire the Electrical Utility Company's calculated available short circuit current. An additional scenario will be considered at 85% of the Utility provided value to assist with Arc Flash Incident Energy Values.

TRES RIOS GPM 2 – GAS DEVELOPMENT R2

Proposal No.: 180032.3

3. CEI shall verify that protective devices are correct per SKM model and analysis results for items affected by scope.
4. Draft Final and Final Report:
 - a. Upon completion of field installation and data verification, by others, CEI will update the SKM model accordingly and submit for approval.
 - b. Upon substantial completion and Arc Flash sign off form provided, CEI shall submit a final report for approval by the City of Phoenix. Final report shall be in PDF format and include all documents as noted below.
 - i. Final Report
 - ii. SKM Single Line Diagrams – Power Study Management Scenario
 - iii. SKM Time Current Curves
 - iv. Arc Flash Labels

Deliverables:

- Draft Final report
- Final sealed report with Arc Flash Sign off form
- Arc Flash Labels and Arc Flash Labeling Sign off form

Task 104 Process Programming

CEI shall generate a Detailed Design Document (DCD), based on the control strategy provided in the specifications, to define the PLC logic and representation of each device and logic used to control equipment. Once this document is agreed upon the PLC/HMI code will be generated to operate the system per the DCD. All IO at the vendor PLC is required, by the Pima County, to be integrated into the Master PLC and HMI.

CEI will coordinate with the team to confirm the specifications and County standards are met. CEI will facilitate workshops to verify through-out the process that the screens provided meet the County standards. CEI will coordinate with panel fabricator to schedule the Factory Acceptance Test and with Ashton for startup. As part of the close out process CEI will provide final documentation and programs in their native format.

TRES RIOS GPM 2 – GAS DEVELOPMENT R2

Proposal No.: 180032.3

Pima County has a second HMI system that requires updates, GE Enervista HMI. This will include the medium voltage switchgear off the medium voltage pad mount switch. CEI will integrate this into the Enervista HMI.

Deliverables:

- Detailed Control Design document (DCD)
- Factory Acceptance Test
- Loop Testing
- Startup/Training
- Record Copy programs in native format with documentation
 1. Rockwell PLC's
 2. Wonderware HMI
 3. Enervista HMI

Task 105 Control Panel CP87B

CEI shall procure PLC control panel CP87B. Procurement shall include, the control panel delivered to the construction site as well as the required documentation as indicated by the construction drawings and specifications.

The panel fee is based on the fact that there are 0 DI channels, 0 DO channels, 11 AI channels and 2 AO channels. An Ethernet module will be provided in the rack. A 13 slot rack will be provided with space to allow future IFM modules to be installed to fill the in the rack. Single non-redundant power supplies have been selected for this application. The enclosure will be NEMA 12 gasketed. This scope includes design, manufacturing, testing and delivery to the site for Ashton to install and wire to field instruments.

Deliverables:

- Shop Drawing Submittals
- Loop Drawing Submittals
- (1) PLC Control Panel CP87B
- Factory Acceptance Test

TRES RIOS GPM 2 – GAS DEVELOPMENT R2

Proposal No.: 180032.3

- PLC Control Panel shipping to site
- O&M Manual Submittals

Task 106 Control Panel CP19

CEI shall procure PLC control panel CP19. Procurement shall include, the control panel delivered to the construction site as well as the required documentation as indicated by the construction drawings and specifications.

The panel fee is based on the fact that there are 3 DI channels, 4 DO channels, 19 AI channels and 6 AO channels. An Ethernet module will be provided in the rack. A 13 slot rack will be provided with space to allow future IFM modules to be installed to fill the in the rack. Single non-redundant power supplies have been selected for this application. The enclosure will be NEMA 12 gasketed. This scope includes design, manufacturing, testing and delivery to the site for Ashton to install and wire to field instruments.

Deliverables:

- Shop Drawing Submittals
- Loop Drawing Submittals
- (1) PLC Control Panel CP19
- Factory Acceptance Test
- PLC Control Panel shipping to site
- O&M Manual Submittals

Assumptions, Exceptions and Clarifications:

- Time lost due to others will be billed at a rate of \$150 per hour plus expenses
- Programming limited to the associated site
- Warranty period on hardware is 12 months from startup date
- Spare IO cards and IFM modules are not included
- Installation by others
- Taxes excluded
- Net 30-day payment

November 5, 2019

TRES RIOS GPM 2 – GAS DEVELOPMENT R2

Proposal No.: 180032.3

- Proposal good for 90 days

Project Schedule:

The initial site visit will begin within 2 weeks from NTP. The initial Power Study submittal will be provided within 20 working days from site visit and receipt of all electrical equipment submittals.

The process programming will begin with the DCD document and will be issued for approval within 20 working days of receiving responses to any Requests for Information. The programming efforts will be coordinated with the construction schedule.

Fee Schedule:

Compensation for services shall be on a lump sum basis per below. Invoices will be submitted monthly based on percent complete.

• Task 101	Lightning Protection	\$ 34,827
• Task 102	PQM Integration	\$ 9,840
• Task 103	Arc Flash	\$ 11,609
• Task 104	Integration of System	\$118,771
• Task 105	Control Panel CP87B	\$ 70,548
• Task 106	Control Panels CP19	<u>\$110,853</u>

Total \$356,448

Proposal Approved, Accepted, and Authorized to Proceed:

By: _____

Print
Name: _____

Title: _____

Date: _____

PO #: _____



3700 E Columbia St, #120
 TUCSON, AZ 85714
 (520) 882 9647
 FAX: (520) 882 7495

Johnson Controls Quotation

TO:
 The Ashton Company, Inc.
 2727 S. Country Club Rd
 TUCSON, AZ 85713-0000

Project: Tres Rios GMP2
 Customer Reference: Tres Rios GMP2
 Johnson Controls Reference: 446410708
 Date: 11/04/2019
 Page 1 of 6

Johnson Controls is pleased to offer for your consideration this quotation for the above project.

QUANTITY	MODEL NUMBER	DESCRIPTION
Tres Rios GMP2		
Ina Road #53 Fire Alarm		
1	4010-9401	4010ES FACP 120V RED
1	4010-9817	MODULAR NETWORK CARD FOR 4010
2	2081-9288	BATTERY 12.7AH
1	ETHEDROP	ETHERNET-NETWORK COMPATIBLE
5	4099-9006	STATION-LED, DA PUSH ADDR
1	4098-9714	PHOTO SENSOR
1	4098-9792	SENSOR BASE
2	4090-9001	SUPERVISED IAM
2	4906-9127	HORN/STROBE MC RED
5	STI-1155	STOPPER II WITH HORN
	DPSCD	DP SVCS BLUPRT/CAD/DRAFT/COPY
	DPSVC	DP SVCS (PERMITS/FEES/BONDS)
1	4100-6072	SM FIBER MODEM LEFT PORT
1	4100-6073	SM FIBER MODEM RIGHT PORT
1	4190-9021	SM LEFT FIBER MODEM RED CAB
3	4906-9101	STROBE MC RED
	Professional Services - Tres Rios GMP2	
	PM LAB	PROJECT/CONSTRUCTION MGMT
	PREP LAB	PRE-SITE PREPARATION LABOR
	Technical Services - Tres Rios GMP2	
	COMM LAB	Commissioning Labor

Total net selling price, FOB shipping point, \$22,973.00

Comments

Excludes estimated sales tax of \$1,300.00

THIS QUOTATION AND ANY RESULTING CONTRACT SHALL BE SUBJECT TO THE GENERAL TERMS AND CONDITIONS ATTACHED HERETO.
 Fire, Security, Communications, Sales & Service
 Offices & Representatives in Principal Cities throughout North America



Johnson Controls Quotation

Comments (continued)

Please read the notes below and call if you have any questions.

Contact Information:

Steve Linde
Electronic Service Sales Representative
520-305-6501
Steven.linde@jci.com

Johnson Controls Scope of Work:

Johnson Controls will provide the listed equipment, plans, permits and technical services for the facility listed above.

Exceptions and/or Clarifications:

Additional devices may be deemed necessary by the AHJ and could result in additional cost.

Electrical contractor will provide and install all conduit and boxes (including the installation of Johnson Controls provided weatherproof boxes and cabinets), pull strings, flexible piping, box blank covers, electrical breakers, terminal cabinets, breaker locks, wire, devices, terminations.

THIS PROPOSAL IS BASED UPON ONLY THOSE ITEMS DENOTED BY [X]':

- Specification section:
- Information from plans Drawing Numbers and Dates: 87 E-500, 87 EF-141 provided by Bartlett & West
- Up to and including addendum:
- Customer provided bill of material
- Verbal request
- Value engineering
- Design Build

THIS QUOTATION INCLUDES ONLY THOSE ITEMS DENOTED BY "[X]":

- Equipment as listed
- Demolition of existing fire alarm devices
- State Sales Tax
- Freight (F.O.B. shipping point)
- Shop Drawings
- PE Sealed Drawings
- Panel terminations
- Technical installation support including programming
- Permit
- Inspection Fees
- Payment/Performance Bonds
- 1 functional system certification test
- 1 AHJ test
- 1 10% Re-Test
- 2 Hours of operation and maintenance training
- Close out documentation

Fire, Security, Communications, Sales & Service
Offices & Representatives in Principal Cities throughout North America



Project: Tres Rios GMP2
Customer Reference: Tres Rios GMP2
Johnson Controls Reference: 446410708
Date: 11/04/2019
Page 3 of 6

Johnson Controls Quotation

Comments (continued)

- Interface to non-SimplexGrinnell provided equipment i.e.: HVAC and elevator
- One year standard warranty
- Monitoring

THIS QUOTATION DOES NOT INCLUDE THE FOLLOWING:

Phased Checkout
Phone lines
Remote station monitoring contract (available upon request)
Knox box
Cutting, drilling, patching, fire caulking or painting
Interface to non-Johnson Controls provided equipment i.e.: HVAC and elevator

It is Johnson Controls understanding that these drawings and specifications represent the work to be accomplished in its entirety and no additional work or materials is expected or required. This quote covers direct costs only and we reserve the right to claim for impact and consequential costs.

ADDITIONAL NOTES:

Quotation is valid for a period of 30 days ONLY unless modified in writing by Johnson Controls.

All work is to be performed during normal Johnson Controls hours of 8am to 5pm Monday through Friday with the exception of company sponsored holidays unless specifically noted otherwise.
We reserve the right to correct this quote for errors and omissions.

As stated above, Johnson Controls will perform the work pursuant to the attached Terms and Conditions. Should the parties fail to execute a mutually agreeable definitive agreement, all work performed by Johnson Controls on or related to the above captioned project (with the exception of any monitoring services anticipated, which will only be performed pursuant to the unaltered terms and conditions of Johnson Controls standard Monitoring Agreement) will be performed pursuant to the attached Terms and Conditions.

Please indicate your approval of this quotation by signing the last page and returning to my attention as noted below.

Steve Linde
Electronic Service Sales
Phone: (520) 882-9647
Cell: (520) 305-6601
Fax: (520) 882-7495
email: steven.linde@jci.com

Fire, Security, Communications, Sales & Service
Offices & Representatives in Principal Cities throughout North America



TERMS AND CONDITIONS (Rev. 9/19)

1. **Payment.** Amounts are due upon receipt of the invoice and shall be paid by Company within 30 days. Invoicing disputes must be identified in writing within 21 days of the invoice date. Payments of any disputed amounts are due and payable upon resolution. All other amounts remain due within 30 days. Work performed on a time and material basis shall be at Company's then-prevailing rate for material, labor, and related items, in effect at the time supplied under this Agreement. Company shall invoice Customer for progress payments to 100% percent based upon equipment delivered or stored, and services performed. In the event project duration exceeds one month, Company reserves the right to submit partial invoices for progress payments for work completed at the project site. Customer agrees to pay any progress invoices in accordance with the payment terms set forth herein. In exchange for close-out documents to be provided by Company, Customer agrees to pay Company the remaining project balance when on-site labor is completed and prior to any final inspections. Customers without established satisfactory credit and Customers who fail to pay amounts when due may be required to make payments of cash in advance, upon delivery or as otherwise specified by Company. Company reserves the right to revoke or modify Customer's credit in its sole discretion. Customer's failure to make payment when due is a material breach of this Agreement and will give Company, without prejudice to any other right or remedy, the right to (a) stop performing any Services and/or withhold further deliveries of Equipment and other materials; terminate or suspend any unpaid software licenses; and/or terminate this Agreement; and (b) charge Customer interest on the amounts unpaid at a rate equal to the lesser of 1.5% per month or the maximum rate permitted under applicable law, until payment is made in full. Customer agrees to pay all of Seller's reasonable collection costs, including legal fees and expenses.

2. **Deposit.** Customer agrees to pay a deposit equal to 30% of the project sell price (pre-tax) prior to Company providing any labor or materials on the project. Company will generate an invoice for the 30% deposit within three business days after Customer's receipt of a written agreement or order from Customer. Company will not commence work until receipt of the deposit

3. **Pricing.** The pricing set forth in this Agreement is based on the number of devices to be installed and services to be performed as set forth in the Scope of Work ("Equipment" and "Services"). If the actual number of devices installed or services to be performed is greater than that set forth in the Scope of Work, the price will be increased accordingly. If this Agreement extends beyond one year, Company may increase prices upon notice to the Customer. Customer agrees to pay all taxes, permits, and other charges, including but not limited to state and local sales and excise taxes, however designated, levied or based on the service charges pursuant to this Agreement. Prices in any quotation or proposal from Company are subject to change upon notice sent to Customer at any time before the quotation or proposal has been accepted. Prices for products covered may be adjusted by Company, upon notice to Customer at any time prior to shipment, to reflect any increase in Company's cost of raw materials (e.g., steel, aluminum) incurred by Company after issuance of Company's applicable proposal or quotation. Pricing for Equipment and material covered by this Agreement does not include any amounts for changes in taxes, tariffs, duties or other similar charges imposed and/or enacted by a government. At any time prior to shipment, Company shall be entitled to an increase in time and money for any costs that it incurs directly or indirectly that arise out of or relate to changes in taxes, tariffs, duties or similar charges due to such changes.

4. **Alarm Monitoring Services.** Any reference to alarm monitoring services in this Agreement is included for pricing purposes only. Alarm monitoring services are performed

pursuant to the terms and conditions of Company's standard alarm monitoring services agreement.

5. **Code Compliance.** Company does not undertake an obligation to inspect for compliance with laws or regulations unless specifically stated in the Scope of Work. Customer acknowledges that the Authority Having Jurisdiction (e.g. Fire Marshal) may establish additional requirements for compliance with local codes. Any additional services or equipment required will be provided at an additional cost to Customer.

6. **Limitation of Liability; Limitations of Remedy.** It is understood and agreed by the Customer that Company is not an insurer and that insurance coverage shall be obtained by the Customer and that amounts payable to company hereunder are based upon the value of the services and the scope of liability set forth in this Agreement and are unrelated to the value of the Customer's property and the property of others located on the premises. Customer agrees to look exclusively to the Customer's insurer to recover for injuries or damage in the event of any loss or injury and that Customer releases and waives all right of recovery against Company arising by way of subrogation. Company makes no guaranty or Warranty, including any implied warranty of merchantability or fitness for a particular purpose that equipment or services supplied by Company will detect or avert occurrences or the consequences therefrom that the equipment or service was designed to detect or avert. It is impractical and extremely difficult to fix the actual damages, if any, which may approximately result from failure on the part of Company to perform any of its obligations under this Agreement. Accordingly, Customer agrees that, Company shall be exempt from liability for any loss, damage or injury arising directly or indirectly from occurrences, or the consequences therefrom, which the equipment or service was designed to detect or avert. Should Company be found liable for any loss, damage or injury arising from a failure of the equipment or service in any respect, Company's liability shall be limited to an amount equal to the Agreement price (as increased by the price for any additional work) or where the time and material payment term is selected, Customer's time and material payments to Company. Where this Agreement covers multiple sites, liability shall be limited to the amount of the payments allocable to the site where the incident occurred. Such sum shall be complete and exclusive. In no event shall Company be liable for any damage, loss, injury, or any other claim arising from any servicing, alterations, modifications, changes, or movements of the Covered System(s) or any of its component parts by Customer or any third party. To the maximum extent permitted by law, in no event shall Company and its affiliates and their respective personnel, suppliers and vendors be liable to Customer or any third party under any cause of action or theory of liability, even if advised of the possibility of such damages, for any (a) special, incidental, consequential, punitive or indirect damages of any kind; (b) loss of profits, revenues, data, customer opportunities, business, anticipated savings or goodwill; (c) business interruption; or (d) data loss or other losses arising from viruses, ransomware, cyber-attacks or failures or interruptions to network systems. The limitations of liability set forth in this Agreement shall inure to the benefit of all parents, subsidiaries and affiliates of Company, whether direct or indirect, Company's employees, agents, officers and directors.

7. **Reciprocal Waiver of Claims (SAFETY Act).** Certain of Company's systems and services have received Certification and/or Designation as Qualified Anti-Terrorism Technologies ("QATT") under the Support Anti-terrorism by Fostering Effective

Technologies Act of 2002, 6 U.S.C. §§ 441-444 (the "SAFETY Act"). As required under 6 C.F.R. 25.5 (e), to the maximum extent permitted by law, Company and Customer hereby agree to waive their right to make any claims against the other for any losses, including business interruption losses, sustained by either party or their respective employees, resulting from an activity resulting from an "Act of Terrorism" as defined in 6 C.F.R. 25.2, when QATT have been deployed in defense against, response to, or recovery from such Act of Terrorism.

8. **General Provisions.** Customer has selected the service level desired after considering and balancing various levels of protection afforded, and their related costs. All work to be performed by Company will be performed during normal working hours of normal working days (8:00 a.m. – 5:00 p.m., Monday through Friday, excluding Company holidays), as defined by Company, unless additional times are specifically described in this Agreement. Company will perform the services described in the Scope of Work section ("Services") for one or more system(s) or equipment as described in the Scope of Work section or the listed attachments ("Covered System(s)"). The Customer shall promptly notify Company of any malfunction in the Covered System(s) which comes to Customer's attention. This Agreement assumes the Covered System(s) are in operational and maintainable condition as of the Agreement date. If, upon initial inspection, Company determines that repairs are recommended, repair charges will be submitted for approval prior to any work. Should such repair work be declined Company shall be relieved from any and all liability arising therefrom. UNLESS OTHERWISE SPECIFIED IN THIS AGREEMENT, ANY INSPECTION (AND, IF SPECIFIED, TESTING) PROVIDED UNDER THIS AGREEMENT DOES NOT INCLUDE ANY MAINTENANCE, REPAIRS, ALTERATIONS, REPLACEMENT OF PARTS, OR ANY FIELD ADJUSTMENTS WHATSOEVER, NOR DOES IT INCLUDE THE CORRECTION OF ANY DEFICIENCIES IDENTIFIED BY COMPANY TO CUSTOMER. COMPANY SHALL NOT BE RESPONSIBLE FOR EQUIPMENT FAILURE OCCURRING WHILE COMPANY IS IN THE PROCESS OF FOLLOWING ITS INSPECTION TECHNIQUES, WHERE THE FAILURE ALSO RESULTS FROM THE AGE OR OBSOLESCENCE OF THE ITEM OR DUE TO NORMAL WEAR AND TEAR. THIS AGREEMENT DOES NOT COVER SYSTEMS, EQUIPMENT, COMPONENTS OR PARTS THAT ARE BELOW GRADE, BEHIND WALLS OR OTHER OBSTRUCTIONS OR EXTERIOR TO THE BUILDING, ELECTRICAL WIRING, AND PIPING.

9. **Customer Responsibilities.** Customer shall furnish all necessary facilities for performance of its work by Company, adequate space for storage and handling of materials, light, water, heat, heat tracing, electrical service, local telephone, watchman, and crane and elevator service and necessary permits. Where wet pipe system is installed, Customer shall supply and maintain sufficient heat to prevent freezing of the system. Customer shall promptly notify Company of any malfunction in the Covered System(s) which comes to Customer's attention. This Agreement assumes any existing system(s) are in operational and maintainable condition as of the Agreement date. If, upon initial inspection, Company determines that repairs are recommended, repair charges will be submitted for approval prior to any work. Should such repair work be declined Company shall be relieved from any and all liability arising therefrom. Customer shall further:

- supply required schematics and drawings unless they are to be supplied by Company in accordance with this Agreement;
- Provide a safe work environment, in the event of an emergency or Covered System(s) failure, take reasonable safety precautions to protect against personal injury, death, and property damage, continue such measures until the Covered System(s) are operational, and notify Company as

soon as possible under the circumstances.

- Provide Company access to any system(s) to be serviced,
- Comply with all laws, codes, and regulations pertaining to the equipment and/or services provided under this Agreement.

Customer is solely responsible for the establishment, operation, maintenance, access, security and other aspects of its computer network ("Network") and shall supply Company secure Network access for providing its services. Products networked, connected to the internet, or otherwise connected to computers or other devices must be appropriately protected by Customer and/or end user against unauthorized access. Customer is responsible to take appropriate measures, including performing back-ups, to protect information, including without limit data, software, or files (collectively "Data") prior to receiving the service or products.

10. Excavation. In the event the Work includes excavation, Customer shall pay, as an extra to the contract price, the cost of any additional work performed by Company dues to water, quicksand, rock or other unforeseen condition or obstruction encountered or shoring required.

11. Structure and Site Conditions. While employees of Company will exercise reasonable care in this respect, Company shall be under not responsibility for loss or damage due to the character, condition or use of foundations, walls, or other structures not erected by It or resulting from the excavation in proximity thereto, or for damage resulting from concealed piping, wiring, fixtures, or other equipment or condition of water pressure. All shoring or protection of foundation, walls or other structures subject to being disturbed by any excavation required hereunder shall be the responsibility of Customer. Customer shall have all things in readiness for installation including, without limitation, structure to support the sprinkler system and related equipment (including tanks), other materials, floor or suitable working base, connections and facilities for erection at the time the materials are delivered. In the event Customer fails to have all things in readiness at the time scheduled for receipt of materials, Customer shall reimburse Company for all expenses caused by such failure. Failure to make areas available to Company during performance in accordance with schedules that are the basis for Company's proposal shall be considered a failure to have things in readiness in accordance with the terms of this Agreement.

12. Confined Space. If access to confined space by Company is required for the performance of Services, Services shall be scheduled and performed in accordance with Company's then-current hourly rate.

13. Hazardous Materials. Customer represents that, except to the extent that Company has been given written notice of the following hazards prior to the execution of this Agreement, to the best of Customer's knowledge there is no:

- "permit confined space," as defined by OSHA,
- risk of infectious disease,
- need for air monitoring, respiratory protection, or other medical risk,
- asbestos, asbestos-containing material, formaldehyde or other potentially toxic or otherwise hazardous material contained in or on the surface of the floors, walls, ceilings, insulation or other structural components of the area of any building where work is required to be performed under this Agreement.

All of the above are hereinafter referred to as "Hazardous Conditions". Company shall have the right to rely on the representations listed above. If hazardous conditions are encountered by Company during the course of Company's work, the discovery of such materials shall constitute an event beyond Company's control and Company shall have no obligation to further perform in the area where the hazardous conditions exist until the area has been made safe by Customer as certified in writing by an independent testing agency, and Customer shall pay disruption expenses and re-mobilization expenses as determined by Company. This Agreement does not provide for the cost of capture, containment or disposal of any hazardous waste materials, or hazardous materials, encountered in any of

the Covered System(s) and/or during performance of the Services. Said materials shall at all times remain the responsibility and property of Customer. Company shall not be responsible for the testing, removal or disposal of such hazardous materials.

14. OSHA Compliance. Customer shall indemnify and hold Company harmless from and against any and all claims, demands and/or damages arising in whole or in part from the enforcement of the Occupational Safety Health Act (and any amendments or changes thereto) unless said claims, demands or damages are a direct result of causes within the exclusive control of Company.

15. Interferences. Customer shall be responsible to coordinate the work of other trades (including but not limited to ducting, piping, and electrical) and for and additional costs incurred by Company arising out of interferences to Company's work caused by other trades.

16. Modifications and Substitutions. Company reserves the right to modify materials, including substituting materials of later design, providing that such modifications or substitutions will not materially affect the performance of the Covered System(s).

17. Changes, Alterations, Additions. Changes, alterations and additions to the Scope of Work, plans, specifications or construction schedule shall be invalid unless approved in writing by Company. Should changes be approved by Company, that increase or decrease the cost of the work to Company, the parties shall agree, in writing, to the change in price prior to performance of any work. However, if no agreement is reached prior to the time for performance of said work, and Company elects to perform said work so as to avoid delays, then Company's estimate as to the value of said work shall be deemed accepted by Customer. In addition, Customer shall pay for all extra work requested by Customer or made necessary because of incompleteness or inaccuracy of plans or other information submitted by Customer with respect to the location, type of occupancy, or other details of the work to be performed. In the event the layout of Customer's facilities has been altered, or is altered by Customer prior to the completion of the Work, Customer shall advise Company, and prices, delivery and completion dates shall be changed by Company as may be required.

18. Commodities Availability. Company shall not be responsible for failure to provide services, deliver products, or otherwise perform work required by this Agreement due to lack of available steel products or products made from plastics or other commodities. In the event Company is unable, after reasonable commercial efforts, to acquire and provide steel products, or products made from plastics or other commodities, if required to perform work required by this Agreement, Customer hereby agrees that Company may terminate the Agreement, or the relevant portion of the Agreement, at no additional cost and without penalty. Customer agrees to pay Company in full for all work performed up to the time of any such termination.

19. Project Claims. Any claim of failure to perform against Company arising hereunder shall be deemed waived unless received by Company, in writing specifically setting forth the basis for such claim, within ten (10) days after such claims arises.

20. Backcharges. No charges shall be levied against Company unless seventy-two (72) hours prior written notice is given to Company to correct any alleged deficiencies which are alleged to necessitate such charges and unless such alleged deficiencies are solely and directly caused by Company.

21. System Equipment. The purchase of equipment or peripheral devices (including but not limited to smoke detectors, passive infrared detectors, card readers, sprinkler system components, extinguishers and hoses) from Company shall be subject to the terms and conditions of this Agreement. If, in Company's sole judgment, any peripheral device or other system equipment, which is attached to the Covered System(s), whether provided by Company or a third party, interferes with the proper operation of the Covered System(s), Customer shall

remove or replace such device or equipment promptly upon notice from Company. Failure of Customer to remove or replace the device shall constitute a material breach of this Agreement. If Customer adds any third party device or equipment to the Covered System(s), Company shall not be responsible for any damage to or failure of the Covered System(s) caused in whole or in part by such device or equipment.

22. Reports. Where inspection and/or test services are selected, such inspection and/or test shall be completed on Company's then current Report form, which shall be given to Customer, and, where applicable, Company may submit a copy thereof to the local authority having jurisdiction. The Report and recommendations by Company are only advisory in nature and are intended to assist Customer in reducing the risk of loss to property by indicating obvious defects or impairments noted to the system and equipment inspected and/or tested. They are not intended to imply that no other defects or hazards exist or that all aspects of the Covered System(s), equipment, and components are under control at the time of inspection. Final responsibility for the condition and operation of the Covered System(s) and equipment and components lies with Customer.

23. Limited Warranty. Subject to the limitations below, Company warrants any equipment (as distinguished from the Software) installed pursuant to this Agreement to be free from defects in material and workmanship under normal use for a period of one (1) year from the date of first beneficial use or all or any part of the Covered System(s) or 18 months after Equipment shipments, whichever is earlier, provided however, that Company's sole liability, and Customer's sole remedy, under this limited warranty shall be limited to the repair or replacement of the Equipment or any part thereof, which Company determines is defective, at Company's sole option and subject to the availability of service personnel and parts, as determined by Company. Company warrants expendable items, including, but not limited to, video and print heads, television camera tubes, video monitor displays tubes, batteries and certain other products in accordance with the applicable manufacturer's warranty. Company does not warrant devices designed to fail in protecting the System, such as, but not limited to, fuses and circuit breakers. Company warrants that any Company software described in this Agreement, as well as software contained in or sold as part of any Equipment described in this Agreement, will reasonably conform to its published specifications in effect at the time of delivery and for ninety (90) days after delivery. However, Customer agrees and acknowledges that the software may have inherent defects because of its complexity. Company's sole obligation with respect to software, and Customer's sole remedy, shall be to make available published modifications, designed to correct inherent defects, which become available during the warranty period. If Repair Services are included in this Agreement, Company warrants that its workmanship and material for repairs made pursuant to this Agreement will be free from defects for a period of ninety (90) days from the date of furnishing.

EXCEPT AS EXPRESSLY SET FORTH HEREIN, COMPANY DISCLAIMS ALL WARRANTIES, EXPRESS OR IMPLIED, INCLUDING BUT NOT LIMITED TO ANY IMPLIED WARRANTIES OF MERCHANTABILITY OR FITNESS FOR A PARTICULAR PURPOSE WITH RESPECT TO THE SERVICES PERFORMED OR THE PRODUCTS, SYSTEMS OR EQUIPMENT, IF ANY, SUPPORTED HEREUNDER.

Warranty service will be performed during Company's normal working hours. If Customer requests warranty service at other than normal working hours, service will be performed at Company's then current rates for after ours services. All repairs or adjustments that are or may become necessary shall be performed by and authorized representative of Company. Any repairs, adjustments or interconnections performed by Customer or any third party shall void all warranties. Company makes no and specifically disclaims all representations or warranties that the services, products, software or third party product or software will be secure from cyber threats, hacking or other similar malicious activity.



24. Indemnity. Customer agrees to indemnify, hold harmless and defend Company against any and all losses, damages, costs, including expert fees and costs, and expenses including reasonable defense costs, arising from any and all third party claims for personal injury, death, property damage or economic loss, including specifically any damages resulting from the exposure of workers to Hazardous Conditions whether or not Customer pre-notifies Company of the existence of said hazardous conditions, arising in any way from any act or omission of Customer or Company relating in any way to this Agreement, including but not limited to the Services under this Agreement, whether such claims are based upon contract, warranty, tort (including but not limited to active or passive negligence), strict liability or otherwise. Company reserves the right to select counsel to represent it in any such action.

25. Insurance. Customer shall name Company, its officers, employees, agents, subcontractors, suppliers, and representatives as additional insureds on Customer's general liability and auto liability policies.

26. Termination. Any termination under the terms of this Agreement shall be made in writing. In the event Customer terminates this Agreement prior to completion for any reason not arising solely from Company's performance or failure to perform, Customer understands and agrees that Company will incur costs of administration and preparation that are difficult to estimate or determine. Accordingly, should Customer terminate this Agreement as described above, Customer agrees to pay all charges incurred for products and equipment installed and services performed, and in addition pay an amount equal to twenty (20%) percent of the price of products and equipment not yet delivered and Services not yet performed, return all products and equipment delivered and pay a restocking fee of twenty (20%) percent the price of products or equipment returned. Company may terminate this Agreement immediately at its sole discretion upon the occurrence of any Event of Default as hereinafter defined. Company may also terminate this Agreement at its sole discretion upon notice to Customer if Company's performance of its obligations under this Agreement becomes impracticable due to obsolescence of equipment at Customer's premises or unavailability of parts.

27. Default. An Event of Default shall be (a) failure of Customer to pay any amount when due and payable, (b) abuse of the System or the Equipment, (c) dissolution, termination, discontinuance, insolvency or business failure of Customer. Upon the occurrence of an Event of Default, Company may pursue one or more of the following remedies: (i) discontinue furnishing Services and delivering Equipment, (ii) by written notice to Customer declare the balance of unpaid amounts due and to become due under this Agreement to be immediately due and payable; (iii) receive immediate possession of any Equipment for which Customer has not paid; (iv) proceed at law or equity to enforce performance by Customer or recover damages for breach of this Agreement, and (v) recover all costs

and expenses, including without limitation reasonable attorneys' fees, in connection with enforcing or attempting to enforce this Agreement.

28. Exclusions. Unless expressly included in the Scope of Work, this Agreement expressly excludes, without limitation, testing inspection and repair of duct detectors, beam detectors, and UV/IR equipment; provision of fire watches; clearing of ice blockage; draining of improperly pitched piping; replacement of batteries; recharging of chemical suppression systems; reloading, upgrading, and maintaining computer software; system upgrades and the replacement of obsolete systems, equipment, components or parts; making repairs or replacements necessitated by reason of negligence or misuse of components or equipment or changes to Customer's premises, vandalism, corrosion (including but not limited to micro-bacterially induced corrosion ("MIC")), power failure, current fluctuation, failure due to non-Company installation, lightning, electrical storm, or other severe weather, water, accident, fire, acts of God or any other cause external to the Covered System(s). Repair Services provided pursuant to this Agreement do not cover and specifically excludes system upgrades and the replacement of obsolete systems, equipment, components or parts. All such services may be provided by Company at Company's sole discretion at an additional charge. If Emergency Services are expressly included in the scope of work section, the Agreement price does not include travel expenses.

29. No Option to Solicit. Customer shall not, directly or indirectly, on its own behalf or on behalf of any other person, business, corporation or entity, solicit or employ any Company employee, or induce any Company employee to leave his or her employment, for a period of two years after termination of this Agreement.

30. Force Majeure; Delays. Company shall not be liable for any damage or penalty for delays or failure to perform work due to acts of God, acts or omissions of Customer, acts of civil or military authorities, Government regulations or priorities, fires, epidemics, quarantine, restrictions, war, riots, civil disobedience or unrest, strikes, delays in transportation, vehicle shortages, differences with workmen, inability to obtain necessary labor, material or manufacturing facilities, cyber-attacks, viruses, ransomware, failures or interruptions to network systems, data breaches, defaults of Company's subcontractors, failure or delay in furnishing complete information by Customer with respect to location or other details of work to be performed, impossibility or impracticability of performance or any other cause or causes beyond Company's control, whether or not similar to the foregoing. In the event of any delay caused as aforesaid, completion shall be extended for a period equal to any such delay, and this contract shall not be void or voidable as a result of the delay. In the event work is temporarily discontinued by any of the foregoing, all unpaid installments of the contract price, less an amount equal to the value of material and labor not furnished, shall be due and payable upon receipt of invoice by

Customer.

31. One-Year Claims Limitation; Choice of Law. No claim or cause of action, whether known or unknown, shall be brought against Company more than one year after the claim first arose. Except as provided for herein, Company's claims must also be brought within one year. Claims not subject to the one-year limitation include claims for unpaid: (a) contract amounts, (b) change order amounts (approved or requested) and (c) delays and/or work inefficiencies. The laws of Massachusetts shall govern the validity, enforceability, and interpretation of this Agreement.

32. Assignment. Customer may not assign this Agreement without Company's prior written consent. Company may assign this Agreement to an affiliate without obtaining Customer's consent.

33. Entire Agreement. The parties intend this Agreement, together with any attachments or Riders (collectively the "Agreement") to be the final, complete and exclusive expression of their Agreement and the terms and conditions thereof. This Agreement supersedes all prior representations, understandings or agreements between the parties, written or oral, and shall constitute the sole terms and conditions of sale for all equipment and services. No waiver, change, or modification of any terms or conditions of this Agreement shall be binding on Company unless made in writing and signed by an Authorized Representative of Company.

34. Severability. If any provision of this Agreement is held by any court or other competent authority to be void or unenforceable in whole or in part, this Agreement will continue to be valid as to the other provisions and the remainder of the affected provision.

35. Legal Fees. Company shall be entitled to recover from the customer all reasonable legal fees incurred in connection with Company enforcing the terms and conditions of this Agreement.

36. License Information (Security System Customers): AL Alabama Electronic Security Board of Licensure 7956 Vaughn Road, Pmb 392, Montgomery, Alabama 36116 (334) 264-9388; AR Regulated by: Arkansas Board of Private Investigators And Private Security Agencies, #1 State Police Plaza Drive, Little Rock 72209 (501)618-8600; CA Alarm company operators are licensed and regulated by the Bureau of Security and Investigative Services, Department of Consumer Affairs, Sacramento, CA, 95814. Upon completion of the installation of the alarm system, the alarm company shall thoroughly instruct the purchaser in the proper use of the alarm system. Failure by the licensee, without legal excuse, to substantially commence work within 20 days from the approximate date specified in the agreement when the work will begin is a violation of the Alarm Company Act: NY Licensed by N.Y.S. Department of the State: TX Texas Commission on Private Security, 5805 N. Lamar Blvd., Austin, 78752-4422, 512-424-7710. License numbers available at www.jci.com or contact your local Johnson Controls office.

IMPORTANT NOTICE TO CUSTOMER

In accepting this Proposal, Customer agrees to the terms and conditions contained herein and any attachments or riders attached hereto that contain additional terms and conditions. It is understood that these terms and conditions shall prevail over any variation in terms and conditions on any purchase order or other document that the Customer may issue. Any changes in the system requested by the Customer after the execution of this Agreement shall be paid for by Customer and such changes shall be authorized in writing. **ATTENTION IS DIRECTED TO THE LIMITATION OF LIABILITY, WARRANTY, INDEMNITY AND OTHER CONDITIONS ON THE PRECEDING PAGES.** This proposal shall be void if not accepted in writing within 30 days from the date of the Proposal.

<p>Offered By: Johnson Controls Fire Protection LP License#: 3700 E Columbia St, #120 TUCSON, AZ 85714</p> <p>Telephone: (520) 882 9647</p> <p>Representative: Steve Linde</p> <p>Email: steven.linde@jci.com</p>	<p>Accepted By: (Customer)</p> <p>Company: _____</p> <p>Address: _____</p> <p>Signature: _____</p> <p>Title: _____</p> <p>P.O.#: _____ Date: _____</p>
---	--

Fire, Security, Communications, Sales & Service
 Offices & Representatives in Principal Cities throughout North America

Ella Yakorevsky

From: Lety@ <rudyruizmasonry@aol.com>
Sent: Tuesday, October 15, 2019 1:23 PM
To: Ella Yakorevsky
Subject: Re: TRWRF 95% Drawings

Good morning Ella, according to our estimator there is no changes made to our scope of work, so that our quote remains. Same goes for our suppliers, at least so far.

Thank you,

Lety
Ruiz Masonry

-----Original Message-----

From: Ella Yakorevsky <Ella@ashtoncoinc.com>
To: Lety@ <rudyruizmasonry@aol.com>
Cc: Shawn Silvester <Shawn@ashtoncoinc.com>
Sent: Mon, Oct 14, 2019 10:46 am
Subject: TRWRF 95% Drawings

Lety,

Please review the attached 95% Drawings for the Biogas Project and provide with the revised quotation (if needed) by Friday, October 18, 2019.

Thank you.

Ella Yakorevsky,
Sr. Project Engineer /
Assistant Project Manager
Industrial Division
THE ASHTON COMPANY, INC.



October 29, 2019

The Ashton Company
Ella Yakorevsky
P.O. Box 26927
Tucson, Arizona 85726

RE: Pima County Tres Rios- BioGas Building Updated

Ella,

Below Please find price to prep and coat outlined items. Proposed coating systems are outlined below. Exposed metal deck and joist are not part of this price.

Proposed Coating Systems

Sound Wall CMU

- Pressure Wash to remove surface contaminates
- Two (2) Coats of Sherwin-Williams A-100 High Performance Acrylic Top Coat

Exposed Metal Surfaces

- Pressure Wash to remove surface contaminates
- SSPC-SP 2 Hand Tool Prep as needed
- One (1) Coat of Sherwin-Williams Pro-Cryl Universal Primer
- One (1) Coat of Sherwin-Williams Sher-Cryl High Performance Acrylic

Interior CMU

- Pressure Wash to remove surface contaminates
- One (1) Coat of Sherwin-Williams Heavy Duty Block Filler
- Two (2) Coats of Sherwin-Williams ProMar 200 Zero VOC Acrylic Top Coat

Interior Gypsum

- Two (2) Coats of Sherwin-Williams ProMar 200 Zero VOC Acrylic Top Coat

Interior Floor Coating

- Pressure Wash to remove surface contaminates
- Two (2) Coats of Sherwin-Williams Macropoxy 646 Epoxy

Breakdown

Building Exterior	\$10,507.00
Sound Wall Exterior	\$ 4,333.00
Building Interior Walls and Gypsum Ceiling	\$ 6,923.00
Building Interior Floor Coating	\$ 4,960.00



3237 E. President St. • Tucson, AZ 85714 • 520-573-0051 • Fax 520-294-8353
ROC-095603 L-34 • ROC-129492 L-05 • Website: www.aopaintinginc.com



If you have any questions, please feel free to contact me at 520-271-1738.

Best Regards,

Alex "Bruiser" Ortega

Alex "Bruiser" Ortega
General Manager
NACE Certified Coating Inspector
Level 3 -Cert. No. 47886

KELLEY

ESTABLISHED IN 1886

PROPOSAL ✓

Tucson Office L-05 Arizona Contr. License # 102509

1331 E 16th street . Tucson, AZ 85719
FX: 520.792.3085 PH: 520.882.4436

We are pleased to present this quotation based on plans, dated 08/01/2019. Door schedule dated 08/01/2019 with no addendum plan pages A4.0.

PROJECT: TRWRF Biogas 60% Drawings REVISED TO 95% PLANS

08 1113- HOLLOW METAL FRAMES AND DOORS

07 EA. 16 g., 3-sided frame

08 EA. Hollow metal doors honeycomb core standard edge seam

Door with lites used metal kit excludes glass and glazing

00 EA. Hollow metal borrowed lites, all to be alum storefront

Frame profiles figured to be with multi-purpose anchors and masonry
Doors that did not have an elevation description were figured to be flush
All Frames and Doors are to be primed for finishing by Other
Excludes field verification of opening sizes, reworking
Excludes all reworking of new and existing openings.
Excludes integral blinds, glass and glazing
Excludes security shutter frames, aluminum frames and doors gates.

Hollow Metal Frames and Doors to be delivered, f.o.b. job site, tailgate If awarded section.
Estimated Lead time for Hollow Metal Frames and Doors will be given after Approved schedules

08 1416- WOOD DOORS NO WOOD DOORS SCHEDULE IN PROJECT DOCUMENTS

08 7100- DOOR HARDWARE for WD / HM door's

Hardware Used DO TO NO SPECIFICATION GIVEN

Dormakaba panics locks closers hinges standard cores non ic. If hardware changes then a change order will need to be done
Pemko seals
Hardware to be prepped at locations per Manufacturer's templates
Keying by other
Excludes Hardware for Aluminum Storefront, Gates, and Roll-up Doors
Excludes Door Signage
Excludes permeant keying
Excludes all materials in Division 28
Excludes installation of Permanent cores (by Owner)

QUALIFICATIONS FOR ELECTRIC HARDWARE AND AUTOMATIC OPENERS

The following to be provided by others:

1. 110-volt electrical wiring
2. Low voltage wiring
3. Conduit and gang boxes
4. Conduit from the electric hinge, EPT, or electric strike to power supply
5. Any wiring to fire alarms or security equipment
6. Interfacing to hardware
7. Wire hangers and fire sleeves
8. Power supplies to be mounted directly over the door
9. Any concrete work
10. Any break metal
11. Any wiring that does not require conduit must have free chase
12. Grouted frames must have free chase
13. Reinforcement or backing at the header if required to mount the Automatic Opener
14. Wiring Diagrams

KELLEY
ESTABLISHED IN 1886

Bros

PROPOSAL

Tucson Office L-05 Arizona Contr. License # 102509

1331 E 16th street . Tucson, AZ 85719
FX: 520.792.3085 PH: 520.882.4436
15.Division 28
16.All Badge Readers
17.All Access control

EXCLUDES ALL INSTALLATION MATERIALS ONLY NUMBER

Elevator required for anything below or above 1st floor.

TOTAL \$ 7,495.00 excludes sales tax

Exclusions: Responsibility for work and materials not part of the above sections, unless specifically noted otherwise. These include tax, bonds, unloading, delivery, installation, glass, glazing, painting, pre-finishing, fieldwork, measuring, field splicing, frame installation, grouting, low voltage connections, lock boxes and bituminous coating (asphaltic emulsion). **Kelley Bros of Arizona always excludes installation of hardware for gates, overhead doors, glass doors & aluminum openings.**

This quotation on material requested is **FOB TUC, tailgate delivery, freight allowed to jobsite, 30-day terms, material billed in-store, and subject to credit approval.** Allow time for special material orders to clear factory to estimate approximate shipping time. Use this Proposal as your purchase order by signing the Acceptance and returning one copy to our office. **Quote good for 30 days.** Notify our office for time extension if required.

Quoted By: Nick Carey Acceptance: _____

Date: 08/20/2019 Revised 10-14-2019 Date: _____



PROGRESSIVE ROOFING



Date: 10/18/2019
To: Ashton Company
Attention: Bidding Department
Re: Biogas
Tucson, Az

Budget Price: \$37,252.00 60 mil TPO with sheet metal

Inclusions: TPO Roof based on 95% drawings
Provide fully adhered (R-38) 2 layers of polyiso over sloped deck.
Provide fully adhered polyiso crickets at curbs.
Provide a fully adhered 60mil white TPO roof system per the manufactures specifications.
Provide base and mechanical flashings per manufacturers specifications and SOW.
Properly flash all curbs and penetrations per the manufactures specifications
Seal drains, scuppers and pipe penetrations.
Provide manufactured coping.
Provide manufacturers scuppers, collector boxes, and downspouts.
Provide two-year contractor warranty.
Provide twenty year manufacturers NDL warranty.

Continued on page 2

Progressive Services, Inc. d.b.a. Progressive Roofing

HOME OFFICE 23 N. 35th Avenue Phoenix, AZ 85009 (602) 278-4900 fax (602) 278-6896	4222 W. Jeremy Place Tucson, AZ 85741 (520) 744-6707 fax (520) 744-3770	13195 Townsend-Winona Rd Flagstaff, AZ 86004 (520) 714-0688 fax (520) 714-0677	3953 W. Oquendo Rd Las Vegas, NV 89118 (702) 798-3973 fax (702) 798-3954	919 Incline Way, Ste Incline Village, NV 89 (702) 831-0588 fax (702) 831-058
---	--	---	---	---



PROGRESSIVE ROOFING



Exclusions:

- General sheet metal and lead products not listed above.
- Aluminum, copper, lead and stainless steel flashings and trim.
- Expansion joint covers, insulation and fire stopping.
- Wood nailers, plywood, blocking and insulation stops.
- Air and vapor barriers. tapered insulation substrate boards and cover boards.
- Equipment/mechanical curbs, supports and covers.
- Insulation on equipment and mechanical curbs.
- Pipe jacks, pipe portals, pitch pans, pipe supports and protection course.
- Sealants contacting any surface other than roof membranes or flashing.
- Scuppers, conductor boxes, gutters and downspouts.
- Temporary roofing.
- Finished roof protection.
- Damp proofing and waterproofing.
- Davis-Bacon wage determinations.
- Bonds, permits, and taxes.
- Unforeseen occurrences.
- All work and items not included in above inclusions.

Hourly Wage Rates:

General Superintendent	\$90.00
Roof Foreman	\$70.00
Roofer	\$65.00
Apprentice	\$54.00
Sheet Metal Workers	\$80.00
Project Estimator	\$120.00

Equipment Rates: Equipment and tools will be included at the rates listed in the Roofing Contract Equipment Cost Schedule published by the NCRA.

Change Order Rates: Subtotal of materials at manufacture's or distributors published list prices plus Labor plus Equipment and Tools will be multiplied by 15% for Overhead; the resulting subtotal will have 5% added for profit.

Notes: see pg 1.

Contact: Robert Gardner at 520-399-8350
robert.gardner@progressiveus.com
 Page 2 of 2

Progressive Services, Inc. d.b.a. Progressive Roofing

<p>HOME OFFICE 23 N. 35th Avenue Phoenix, AZ 85009 (602) 278-4900 fax (602) 278-6896 estimating fax (602) 278-8014</p>	<p>4222 W. Jeremy Place Tucson, AZ 85741 (520) 744-6707 fax (520) 744-3770 estimating fax (602) 844-8321</p>	<p>13195 Townsend-Winona Rd Flagstaff, AZ 86004 (520) 714-0688 fax (520) 714-0677 estimating fax (602) 844-8321</p>	<p>3953 W. Oquendo Rd Las Vegas, NV 89118 (702) 798-3973 fax (702) 798-3954 estimating fax (602) 844-8321</p>	<p>919 Incline Village Incline Village, NV (702) fax (702)</p>
---	--	---	---	---



Builder Services Group, Inc. d/b/a Gale Contractor Services
 Lic# ROC189642, ROC190026, ROC194618, ROC196061, ROC269072
 3875 E Michigan St. Tucson, AZ 85714-3287
 Tel: (520) 325-0751, Fax: (520) 790-9449

WORK AGREEMENT

TO: THE ASHTON COMPANY INC / 861778	RE: Tres Rios WRF - 95% Plans / Insulation	
Address: 2727 S COUNTRY CLUB PO BOX 26927, TUCSON, AZ, 85713	Address: 7101 N CASA GRANDE HWY TUCSON, PIMA, AZ, 85743	
Attn:	Date: 10/18/2019	Expiration Date: 01/16/2020
Tel: (520) 624-5500	Estimator: Koosman, Mark	
Fax:	Quote #: 75674480	Version 1 of 1
	Division #: 067 - TUCSON AZ, GCS	

Subject to the terms and conditions stated in this agreement, Contractor is willing to furnish to you all material and labor required for the Scope of Work described below:

Scope of Work (the "Work") to be performed:

Draft stop, fire block, fire stop (UBC 708.2.1 et seq., formerly 2516(f), or locally adopted equivalent), and fire rated caulking are not included within Contractor's Work unless specifically listed below.

Plan #: NA | NA

Trade: INSULATION

Work Area	Product	Notes
EXTERIOR WALLS	IBA KN R-11 UNF 24"X96" 256 SF SC FSK HD FACING 54"	R-11 UNFACED BATTS AT 3 5/8" FURRED EXTERIOR WALLS FSK SCRIM FACING OVER FRAMING AT EXTERIOR WALLS
INTERIOR PARTITIONS	IBA KN R-11 UNF 16"X96" 170.67 SF SC IBA KN R-19 UNF 16"X96" 106.67 SF SC	R-11 UNFACED BATTS AT 3 5/8" FRAMED INTERIOR WALLS R-19 UNFACED BATTS AT 6" FRAMED INTERIOR WALLS

Base Price: \$1,530.00

Additional Information: SALES TAX \$87 - TOTAL w/ TAX: \$1,617.00

SALES TAX - ROOF \$76 - TOTAL ADD w/ TAX: \$1,416.00

Options

Initial

ROOF INSULATION	IBA KN R-38 UNF 24"X48" 64 SF Notes: R-38 UNFACED BATTS WIRED TO UNDERSIDE OF ROOF DECK - NOTE NOT SHOWN ON PLANS, BUT CALLED FOR IN SPECS FSK HD FACING 54" Notes: FSK SCRIM FACING BELOW INSULATION WIRED TO DECK	
		+\$1,340.00



Builder Services Group, Inc. d/b/a Gale Contractor Services
 Lic# ROC189642, ROC190026, ROC194618, ROC196061, ROC269072
 3875 E Michigan St. Tucson, AZ 85714-3287
 Tel: (520) 325-0751, Fax: (520) 790-9449

WORK AGREEMENT

TO: THE ASHTON COMPANY INC / 861778	RE: Tres Rios WRF - 95% Plans / Insulation	
Address: 2727 S COUNTRY CLUB PO BOX 26927, TUCSON, AZ, 85713	Address: 7101 N CASA GRANDE HWY TUCSON, PIMA, AZ, 85743	
Attn:	Date: 10/18/2019	Expiration Date: 01/16/2020
Tel: (520) 624-5500	Estimator: Koosman, Mark	
Fax:	Quote #: 75674480	Version 1 of 1
	Division #: 067 - TUCSON AZ, GCS	

NOTE: This agreement consists of multiple pages. If you do not receive the number of pages noted below, please contact Contractor directly at the telephone number stated above.

TERMS OF PAYMENT: Payment in full due as stated on invoice regardless of any payment arrangements you have with third parties.

ACCEPTANCE: Contractor may change and/or withdraw this agreement if Contractor does not receive your signed acceptance within 10 business days after the Date stated above.

PRICING: The prices stated in the Scope of Work above will remain firm for 90 days after the Date stated above. If performance of this agreement extends beyond this 90 day period, you agree to pay Contractor's then current pricing ("Price") for any Work performed after that 90 day period. The Prices are based only on the terms and conditions expressly stated in this agreement. The Prices exclude any and all terms and conditions not expressly stated herein, including, without limitation, any obligation by Contractor to name you or any third-party as an additional insured on its insurance policy; to provide per project aggregate insurance coverage for the Work; to participate in any owner controlled, wrap, or similar insurance program; to indemnify or defend you or any third-party from any claims, actions and/or lawsuits of any kind or nature whatsoever except to the limited extent state in Section 18 of this agreement. Any terms or conditions required by you by contract or otherwise in addition to or inconsistent with those expressly stated in this agreement will result in additional charges and/or higher Prices. Any additional work performed is subject to Contractor's then current pricing (unless Contractor otherwise agrees in writing) and to this agreement.

CUSTOMER:

CONTRACTOR:

By: _____
 SIGNATURE TITLE

By: _____
 SIGNATURE TITLE

Company Name _____

Date: _____

THE INFORMATION CONTAINED IN THIS AGREEMENT IS CONFIDENTIAL. NEITHER THIS AGREEMENT NOR ITS TERMS MAY BE DISCLOSED TO THIRD PARTIES.

1. **ACCEPTANCE.** This agreement is expressly limited to and made conditional upon your acceptance of its terms and conditions. Any of your terms and conditions which are in addition to or different from those contained herein which are not separately agreed to in writing (except additional provisions specifying quantity, description of the products or work ordered and shipping instructions) are deemed material and are hereby objected to and rejected. You waive your objection to any terms and conditions contained herein if Contractor does not receive written notice of your objection within ten business days of the date of this agreement. You will in any event be deemed to have assented to all terms and conditions contained herein if any part of the products or work described herein are provided or performed. Please note particularly the Limited Warranty, Limitation of Remedies and Limitations on Actions and Liability provisions set forth below. You acknowledge that the prices stated are based on the enforceability of these terms and conditions, and on the Limited Warranty, Limitation of Remedies and Limitation of Actions and Liability provisions below, that the price would be substantially higher if Contractor could not limit its liability as herein provided, and that you accept these provisions in exchange for such lower prices.
2. **LIMITED WARRANTY.** All work performed by Contractor is warranted to be free from defects in material and workmanship for one year from the date of completion of the installation subject to the terms below. Contractor makes no warranties regarding products sold but assigns to you any manufacturer warranties relating to the products. **THIS EXPRESS WARRANTY IS IN LIEU OF AND EXCLUDES ALL OTHER WARRANTIES, WHETHER EXPRESSED, IMPLIED OR STATUTORY, INCLUDING IMPLIED WARRANTIES OF MERCHANTABILITY OR FITNESS FOR A PARTICULAR PURPOSE.** This limited warranty does not cover damages relating to (a) accident, misuse, abuse, neglect, or normal wear and tear; (b) failure to use or maintain the product in accordance with manufacturer's instructions; and (c) alteration, repair or attempted repair by anyone other than Contractor or its authorized representative. You shall be solely responsible for the correctness of the plans and specifications and shall release and hold harmless Contractor from any damages resulting from improper, inadequate or vague information supplied by you. Contractor does not take on any obligation to inspect or evaluate the work of other parties in any manner or aspect. This warranty is not transferable.
3. **INSURANCE.** Contractor shall maintain workers' compensation (employer liability), as required by law, and \$1,000,000 in general liability insurance while performing the work. Contractor reserves the right to be self insured to the extent allowed by applicable law. Contractor does not agree to name any other persons or entities as additional insureds.
4. **LIMITATION OF REMEDIES.** Your sole and exclusive remedy against Contractor for any and all claims for damages arising out of or alleged to have arisen out of the Work will be limited to the repair or replacement by Contractor, at Contractor's option, of any nonconforming work or to the issuance of a credit for such nonconforming work in accordance with these terms and conditions provided Contractor is given a reasonable opportunity to inspect the work and confirms such nonconformity. This exclusive remedy shall not be deemed to have failed of its essential purpose so long as Contractor is willing and able to repair or replace the nonconforming work and, in any event, Contractor's maximum liability for any damages shall be limited to the total amount paid to Contractor for the Work under this agreement. This Limitation of Remedies clause shall apply to the parties to this agreement as well as to the current owner(s) of the project and its' their respective successors and assigns. If you receive a claim for damages by any owner arising out of or alleged to have arisen out of the Work, you agree to give written notice to Contractor of the claim and provide Contractor an opportunity to inspect the alleged damages within 30 days after Contractor's receipt of the notice. If you fail to give the required notice and/or fail to allow Contractor an opportunity to inspect the alleged damages within 30 days, you hereby waive any and all rights for damages and/or correction of work against Contractor. This Limitations of Remedies may be plead as a complete bar to any action in violation of this clause.
5. **LIMITATIONS ON ACTIONS AND LIABILITY.** All claims and/or lawsuits including but not limited to claims or lawsuits for indemnity and/or contribution against Contractor arising under this agreement must be made within 13 months from the date of completion of the installation. **CONTRACTOR WILL NOT BE LIABLE FOR ANY LOSS, DAMAGE OR INJURY RESULTING FROM DELAY IN DELIVERY OF THE PRODUCTS OR FOR ANY FAILURE TO PERFORM THAT IS DUE TO CIRCUMSTANCES BEYOND ITS CONTROL. CONTRACTOR DISCLAIMS ALL LIABILITY FOR ANY AND ALL DAMAGE WHICH MIGHT BE SUSTAINED BY ANY PERSON WHO MAY BE ALLEGED TO OR AFFECTED BY THE EMANATION OF PARTICLES FROM CERTAIN TYPES OF INSULATION. THE MAXIMUM LIABILITY, IF ANY, OF CONTRACTOR FOR ALL DAMAGES, INCLUDING WITHOUT LIMITATION CONTRACT DAMAGES AND DAMAGES FOR INJURIES TO PERSONS OR PROPERTY, WHETHER ARISING FROM CONTRACTOR'S BREACH OF THIS AGREEMENT, BREACH OF WARRANTY, NEGLIGENCE, STRICT LIABILITY OR OTHER TORT WITH RESPECT TO THE PRODUCTS, OR ANY SERVICES IN CONNECTION WITH THE PRODUCTS, IS LIMITED TO AN AMOUNT NOT TO EXCEED THE CONTRACT PRICE. IN NO EVENT SHALL CONTRACTOR BE LIABLE FOR ANY INCIDENTAL, CONSEQUENTIAL, LIQUIDATED, OR SPECIAL DAMAGES, INCLUDING WITHOUT LIMITATION, LOST REVENUES AND PROFITS, ATTORNEYS FEES AND/OR COSTS EVEN IF IT HAS BEEN ADVISED OF THE POSSIBILITY OF SUCH DAMAGES. THE RIGHT TO RECOVER DAMAGES WITHIN THE LIMITATIONS SPECIFIED IS YOUR EXCLUSIVE REMEDY IN THE EVENT THAT ANY OTHER CONTRACTUAL REMEDY FAILS OF ITS ESSENTIAL PURPOSE.**
6. **PRICES, TERMS AND SHIPMENT.** No cash discounts, back charges, set offs or counterclaims are allowed unless specified by Contractor. In addition to the prices specified, you agree to pay any federal, state or local excise, use, occupational, or similar tax now in force or to be enacted in the future, assessed against Contractor or you by reason of this transaction. No retention is permitted unless Contractor agrees otherwise in writing. Any past due payment will be, at Contractor's option, subject to interest at 1.5% per month (18% per annum) to the extent permitted by law. You agree to receive (or permit Contractor to receive) near the work site, any materials needed to complete the Work. You agree to protect such materials from damage or loss and provide Contractor, free of charge, with reasonable use of light, heat, water, power, storage space and use of available elevators and hoists as needed. Title to all materials under this agreement shall not transfer to you until Contractor receives payment in full. Contractor may charge you a fee and its actual expenses if the job site is not ready for work on the date you specify.
7. **FORCE MAJEURE.** Contractor shall not be liable for any delay, failures, or default in performance of this agreement or otherwise, in whole or in part, caused by the occurrence of any contingency beyond the control either of Contractor or of suppliers to the Contractor. Such contingencies include but are not limited to failure or delay in transportation, acts of any government or any agency or subdivision thereof, judicial action, labor disputes, fire, accident, acts of nature, severe weather, product allocation or shortages, labor shortages, fuel shortages, raw material shortages, machinery or technical failure, or work that cannot be completed because of another contractor covering the pertinent portion of the building. If any contingency occurs, Contractor may allocate production, deliveries, and performance of work among its customers or substitute substantially similar materials, in its sole discretion, without liability for doing so.
8. **CONFIDENTIALITY.** If you visit Contractor's premises or you otherwise receive any proprietary or confidential information from Contractor, you shall retain such information as confidential and not use or disclose it to any third party without Contractor's written consent.
9. **CREDIT APPROVAL.** Shipment and delivery of goods and performance of work shall at all times be subject to the approval of Contractor's credit department and Contractor may at any time decline to make any shipment or delivery or perform any work except upon receipt of payment or upon terms and conditions or security satisfactory to Contractor. By signing this agreement, you authorize Contractor to check your credit and references.
10. **CANCELLATION.** This agreement, or any part of it, may only be cancelled with Contractor's written approval. In the event of cancellation of this agreement, or any part hereof, you shall pay: (a) the contract price of all completed items; (b) that portion of the contract price that is equal to the degree of completion of products or work in process, effective on the date Contractor receives notice of cancellation; (c) the cost of any materials and supplies which Contractor shall have purchased to perform and which cannot be readily resold or used for other or similar purposes; (d) a restocking fee; and (e) any expenses incurred by Contractor (including legal fees and judgments) as a result of the cancellation of subcontracts or purchases related to this agreement.
11. **DEFAULT.** You may terminate this agreement for Contractor's default, wholly or in part, by giving Contractor written notice of termination as follows. You may give a written notice of termination only if Contractor has received a written notice from you specifying such default, the default is not excusable under any provision hereof, and the default has not been remedied within thirty (30) days (or such longer period as may be reasonable under the circumstances) after Contractor's receipt of the notice of default. Delivery of nonconforming products or work by Contractor shall give you the rights set forth in paragraph 4 hereof but shall not be deemed a default for purposes of termination. In the event of termination for default, you shall be relieved of the obligation to pay for work not performed by Contractor prior to the effective date of such termination. A default on Contractor's part shall not subject Contractor to liability, through payment by Contractor, set off or otherwise, for any other damages, whether direct, consequential or incidental, and whether sought under theories of contract or tort.
12. **ASSIGNMENT.** You may not assign this agreement or any claim against Contractor relating to this agreement.
13. **GOVERNING LAW.** This agreement shall be construed, interpreted and the rights of the parties determined in accordance with the laws of the State of Contractor's address first listed on the front of this agreement.
14. **DISPUTES AND MANDATORY MEDIATION.** In the event that a dispute arises over the reasonableness of or entitlement to fees charged by Contractor, the prevailing party will be entitled to reasonable attorneys fees and costs. In all other disputes of any nature, each party shall pay its own fees and costs. Except as required to protect confidential information and to obtain preliminary injunctive relief to prevent irreparable harm, you and the Contractor agree that prior to the initiation of any legal action the parties will engage in facilitative mediation of any and all disputes in any way related to this agreement. If the parties cannot agree upon a facilitative mediator within 30 days of when the dispute arose, one will be selected pursuant to the Commercial Mediation Rules of the American Arbitration Association. Each party will share equally the fees of the facilitative mediator and costs of the mediation.
15. **INSULATION DOES NOT PREVENT FROZEN PIPES.** Insulating around water lines in an unconditioned or semi-conditioned area will not prevent pipes from freezing or accumulating condensation. To decrease the possibility of frozen pipes, locate any water pipes within a conditioned area, such as internal walls rather than external walls. If You do not locate the pipes within an internal wall, you hold Contractor harmless and release Contractor from any claims relating to frozen or burst pipes.
16. **SEVERABILITY.** If any provision on this agreement is not enforceable, that provision shall be effective only to the extent permitted by law and all other provisions of this agreement shall remain.
17. **ENTIRE AGREEMENT.** This instrument contains the entire agreement of the parties relating to the subject matter hereof and may only be waived, changed, modified, extended or discharged orally by a writing signed by the party against whom enforcement of any such waiver, change, modification, extension or discharge is sought. The terms and conditions of this agreement supersede any agreement to which it is attached.
18. **INDEMNITY.** Each of the parties to this agreement agrees to defend and indemnify one another from any and all claims, actions and/or lawsuits caused by the party's negligent acts or omissions. This indemnity clause and the obligations created herein shall control and take priority over any contrary indemnity agreement entered into prior to this agreement. Furthermore, this indemnity clause and the obligations created herein shall control and take priority over any contrary indemnity agreement entered into subsequent to this agreement unless the subsequent agreement specifically refers to this indemnity clause and declares it null and void.



Revised Revised PROPOSAL

Date: 8/12/19 -8/20/19 - 10-29-19

Project: Tres Rios Gas Development

Submitted To: Ashton General Contractors

Attention: Estimators

Proposed services and equipment are limited to items specifically listed below

HVAC: Provide and Install (1) Mitsubishi Condensing unit, (4) air handlers, (1) exhaust fan, (1) louver with motorized damper, refrigerant and condensate piping, TAB, Climatec Control Integration, Warranty

Plumbing: Provide and Install (1) water closet, (1) Lavatory sink with faucet, (1) mop sink, (1) tankless water heater, (1) Backflow device, (1) floor drain with trap primer, (2) hose bibbs, (1) yard hydrant, Cleanouts, PVC Waste and Vent piping, Copper domestic water piping with insulation per schedule, Back flow cert. Testing

Excludes: Sawcutting, Concrete patch, Concrete equipment pad, Davis Bacon Wages, The servicing, support and warranty of existing material and equipment or owner provided equipment. Fire alarm work, framing, blocking, structural framing, relocation of existing utilities, blue staking, taxes/ permits/ fees. , Fire Sprinklers, Architectural Metals and HVAC are not necessarily included in the proposal, the proposal outlines what scope of work we are covering. When we quote multiple scopes of work please check before assuming we will accept a contract for selective portions.

Terms: Net 30 Days

Base Bid: \$59,121.00 (+ tax \$1,664.00)

We appreciate your consideration of this quotation and would like to thank you for your interest in Advantage Air Mechanical's services. Should you have any questions concerning the above quotation, please feel free to contact me personally @ (520) 780-6483 or at Rob@AdvantageAirMechanical.com.

Respectfully Submitted,

Rob Larson

ACCEPTANCE OF PROPOSAL: All work is guaranteed to be as specified. All work to be completed in a professional manner according to standard practices. Any alteration or deviation from above specifications involving extra costs will be executed only upon written orders and will become an extra charge over and above the estimate. All agreements contingent upon delays beyond our control. Purchaser agrees to pay all costs of collection, including attorneys' fees. This proposal may be withdrawn within 20 days if not accepted. Advantage Air Mechanical to carry necessary insurance upon above work including workman's compensation and liability insurance. Advantage Air Mechanical does not employ any mechanical engineers. Equipment and distribution designed by Advantage Air is not guaranteed to achieve specific design criteria other than that which said equipment is rated for. Advantage Air Mechanical is licensed and bonded. All equipment and material are property of Advantage Air Mechanical until payment in full is made.

Date of acceptance:

Signature:

www.AdvantageAirMechanical.com

3238 East Forty Fifth Street Tucson, Arizona 85713

(520) 792-9400 Main (520) 885-3904 Fax

ROC No.214570 K-39/ C-39R Air Conditioning and Refrigeration

ROC No.263466 K-77/ L-77/C-37/ C-37R Plumbing, Solar and Fire Protection

ROC No. 263465 Architectural Sheet Metal

SBE Certified

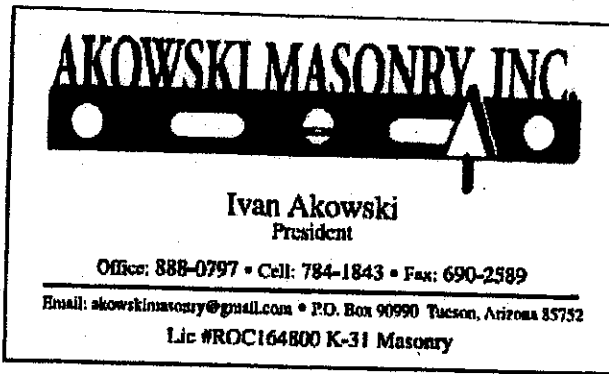

Date: 10/16/2016
Job Name: Bldg 53- Tres Rios- REVISED 10/16/2019
Address: Pima County

Proposal to furnish the following described materials and labor for the above project upon the terms and conditions herein set forth.

Price Includes:

104 LF of 14' high 8" CMU wall. CMU bid as natural grey
This price does not include rebar
TOTAL PRICE- \$22,409.00

137'4 LF of exterior wall 18' high
18'8 LF of interior wall 14' high
All CMU to be 8x8x16 natural grey
Labor, material, rebar and equipment
TOTAL PRICE- \$41,200.00

EXCLUDED:

Footings or Concrete grade beams
Misc. steel, embeds for framing- furnishing or installing door/window frames
Building permits, fees, plan check costs-taxes, bonding or special inspections.
Weather protection during masonry installation
Overtimes
Cleaning or stain removal caused by others.
Stucco, paint, stain, sealants, weather or waterproofing.
Layout of bldg. corners/layout of supplied embeds.
Water source for mixing
Dumpster for debris
Removal or pumping of rain water from footings

Contact: Ivan Akowski @ 520-888-0797 520-784-1843 (cell) Akowskimasonry@gmail.com

VERBAL QUOTATION

The ASHTON Co.

TRWRF
Job B109AS
60% Drawings

FIRM WGVAL (Valenzuela Drywall) Phone 887-5652 Date 8/21/19

BID ON Steel Studs & Drywall By Tom Arino Time 11:30 a.m.

Per Plans & Specs YES No

ADDENDA ACKNOWLEDGED _____

C.I.P. F.O.B. Job F.O.B. _____

BASE BID

\$ 30,000 -

Haul off and disposal of debris offsite? Yes No Stockpiled Only

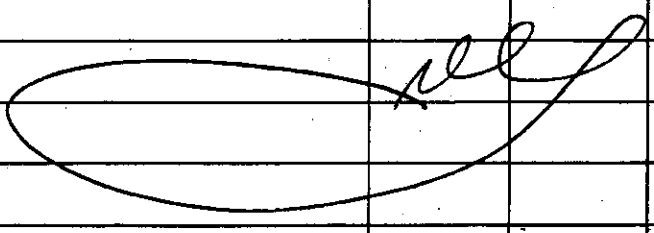
Inclusions - Exclusions & Qualifications	Item No.	Quan.	Unit Bid	Total Bid
ALTERNATES:				
<u>Budgetary Proposal</u>				
<u>OK on 10/25/19</u>				
				

Wall Systems

a division of Exterior Wall Systems, Inc.

old

Date: 8-19-19

ABSTRACT

PROJECT: TRES RIOS BIOGAS

DIVISION: EXTERIOR INSULATION AND FINISH SYSTEM (EIFS)

DESCRIPTION OF WORK: Dryvit Outsulation Class PB. 1½" foam over masonry with primus adhesive. Standard netting with primus over coat. Aqua flash and grid tape around windows and doors. Finish with Dryvit Moajve allowing for 2 colors

OK ✓
[Signature] 10/25/19

EXCLUSIONS: Sales tax, bond, caulking, flashing, sheathing, framing and removal of trash from the site.

NOTE: If we do not have a current tax exempt certificate on file, we will add sales tax at billing time.

THIS BID IS BASED ON A SCHEDULE WITH OUR INPUT OF TIME NEEDED AND ON CURRENT MATERIAL PRICING AND FOLLOWING OSHA RECOMMENDED PRACTICES FOR OUR TRADE.

ADDENDUMS NOTED:

BASE BID AMOUNT: \$21,903.00

CONTACT PERSON FOR BID: Travis Sharp @ 574-4257

ACCEPTED BY: _____ DATE: _____

THE ASHTON COMPANY
TRES RIOS WASTER WATER TREATMENT FACILITY
BIOGAS PROJECT (GMP 2)
7101 NORTH CASA GRANDE HIGHWAY
TUCSON, ARIZONA

MATERIALS TESTING AND SPECIAL INSPECTION

	<u>Rate</u>	Units
Geotechnical Engineer	\$100.00	Per Hour
Project Manager	\$90.00	Per Hour
Special Inspector (Portal to Portal with 2 Hour Minimum)	\$65.00	Per Hour
Weekly Quality Control Summary Report	\$100.00	Each
Engineering Technician (Portal to Portal with 2 Hour Minimum)	\$45.00	Per Hour
Trip Charge (Includes Tech, Vehicle and Equipment)	\$65.00	Each

LABORATORY TESTS:

SOILS OR AGGREGATE BASE MATERIALS:

Moisture Density Relations/ Proctors (Modified Method)	\$135.00	Each
Moisture Density Relations/ Proctors (Standard Method)	\$120.00	Each
Moisture Content, Soil or Aggregate (Laboratory)	\$20.00	Each
Sieve Analysis	\$85.00	Each
Plasticity Index (Dry Preparation)	\$55.00	Each
Remolded Swell	\$75.00	Each
pH and Resistivity	\$125.00	Each

CONCRETE, MORTAR OR GROUT:

Compressive Strength (Concrete, Mortar or Grout)	\$15.00	Each
Drilled Core - Compressive Strength with Unit Weight	\$50.00	Each

ASPHALT:

Oil Content by Ignition w/Gradation	\$155.00	Each
Marshall Bulk Density	\$110.00	Each
Maximum Theoretical Density (Rice)	\$110.00	Each
Thickness/Density of Asphaltic Concrete Cores	\$35.00	Each
Sand Equivalent	\$70.00	Each
Fractured Faces	\$90.00	Each
Uncompacted Voids	\$90.00	Each

SBE Certified Company
A Tucson Only Based Company

Note: Final contract amount to be determined by services rendered. CTEC does not guarantee the accuracy of probable costs for testing services. An Overtime Rate of 1.5 will be applied to labor over 8 hours per day, Saturday, Sunday & Holidays. One hour minimum on site to apply for all site visits. Technician Time is for On Site Time Only. Valid thru 12-31-19.

Date Prepared: 08-19-2019

Prepared By: /s/ Jon C. Hoffman

signed copy on file

Jon C. Hoffman, Materials Unit Manager

ConformaTech, Inc.
 1425 East Apache Park Place
 Tucson, Arizona 85714
 Tel.: (520) 573-2045
 Fax: (520) 573-0528



4249 W. Valencia Rd. ■ Tucson, AZ 85746 ■ Office: (520) 883-5940 ■ Fax: (520) 883-1043

To Estimating Department:

Date: 8-14-19

We are a Minority Business Enterprise and will be bidding labor and material, per plan and spec, for section 4200 (Masonry) for the job listed below:

Job Name Tres Rios Gas Building - 60% Plans

Bid Date 8/14 Price \$ 34,491.00 Alt # _____

Acknowledge 0 Addendums. Alt # _____
Alt # _____

Our scope of work for this project is as follows:

1. Installation only of rebar. To furnish **ADD \$** 2,458.00
2. Installation only of embeds weighing less than 200 pounds.
3. Grouting of hollow metal door frames included.
4. Sealing or waterproofing of block **NOT INCLUDED!!!!**
5. Installation only of flashing or reglet.
6. Install hollow metal door frames? Yes
7. Furnish and install backer rod and caulking? NO
8. Furnish and/or install insulation? NO
9. Furnish and/or install precast? NO
10. Dry packing? NO
11. Shoring? NO
12. Bracing, if required, for this job ADD \$ NO
13. Masonry stem wall, height will be from top of footer, included? N/A
14. **Footing is NOT included!**
15. Glass block set in masonry only? No
16. Removal of debris will consist of putting it in general contractor's dumpster.
17. Bond? NO
18. Other? Plain Cmu Block
19. **This bid proposal is contingent upon reasonable contract terms.**
21. **ABOVE PRICE IS VALID ONLY FOR THIRTY (30) DAYS.**

We are bondable at a rate of 1.5% with Schaefer-Smith-Ankeney Insurance Agency, P.O. Box 10067 Phoenix, AZ 85016. George Mendez is our bonding agent and can be reached at (602) 977-3509

For any questions on this bid call Lety at (520) 883-5940. **Good Luck!!!!**



4249 W. Valencia Rd. Tucson, AZ 85746 Office: (520) 883-5940 Fax: (520) 883-1043

an Equal Opportunity Employer

To Estimating Department:

Date: 8-14-19

We are a Minority Business Enterprise and will be bidding labor and material, per plan and spec, for section 4200 (Masonry) for the job listed below:

Job Name Tres Rios Sound Wall - No structural Plans

Bid Date Price \$ 37,758.00 Alt # Acknowledge Addendums. Alt # Alt #

Our scope of work for this project is as follows:

- 1. Installation only of rebar. To furnish ADD \$ 1,890.00
2. Installation only of embeds weighing less than 200 pounds.
3. Grouting of hollow metal door frames included.
4. Sealing or waterproofing of block NOT INCLUDED!!!!
5. Installation only of flashing or reglet.
6. Install hollow metal door frames? N/A
7. Furnish and install backer rod and caulking? NO
8. Furnish and/or install insulation? N/A
9. Furnish and/or install precast? N/A
10. Dry packing? NO
11. Shoring? NO
12. Bracing, if required, for this job ADD \$ NO
13. Masonry stem wall, height will be from top of footer, included? N/A
14. Footing is NOT included!
15. Glass block set in masonry only? No
16. Removal of debris will consist of putting it in general contractor's dumpster.
17. Bond? NO
18. Other? 140' x 10' Fluted, split face Block Screen Wall
19. This bid proposal is contingent upon reasonable contract terms.
21. ABOVE PRICE IS VALID ONLY FOR THIRTY (30) DAYS.

We are bondable at a rate of 1.5% with Schaefer-Smith-Ankeney Insurance Agency, P.O. Box 10067 Phoenix, AZ 85016. George Mendez is our bonding agent and can be reached at (602) 977-3509

For any questions on this bid call Lety at (520) 883-5940. Good Luck!!!!

Tyler Reinforcing LLC

PO Box 6520 (602) 269-5900
 Phoenix, AZ 85005
 Lic No: AZ ROC #296786

Proposal No: **190504.2**
 Proposal Date: **10/16/2019**

*This proposal is valid for
 30 days from date shown above.*

BID PROPOSAL

SECTION I- GENERAL INFORMATION

Proposal to: **Bidding Contractors** Project Name: **Tres Rios Bio Gas Building**
 Attn: **Estimating Dept.** Ref. No.:
 Engineer: **Structural Concepts** Owner: **Pima County Water Reclamation**
 Drwgs Quoted: **Sheets S1 thru S5**
Preliminary Not for Construction - 95% Submittal dated 9/19
 Specs:
 Addenda:

SECTION II- SCOPE OF WORK

Concrete Deformed Reinforcing Steel Detailed, Furnished & Installed per ACI & CRSI Standards.
 Masonry Deformed Reinforcing Steel Furnished FOB Trucks Jobsite per ACI & CRSI Standards.

SECTION III- PRICES

Bid Item	Description	Material	Labor	Total
	Building - Concrete Reinforcing	\$1,588.00	\$1,060.00	\$2,648.00
	Building - Masonry Reinforcing	\$2,490.00	FOB	\$2,490.00
		\$0.00	FOB	\$0.00
	Sound Wall - Concrete Reinforcing	\$676.00	\$466.00	\$1,142.00
	Sound Wall - Masonry Reinforcing	\$1,290.00	FOB	\$1,290.00
		\$0.00	FOB	\$0.00
	Bus Duct Supports - Concrete Reinforcing	\$1,504.00	\$997.00	\$2,501.00
		\$0.00	FOB	\$0.00
		\$0.00	FOB	\$0.00

Taxes are EXCLUDED from prices shown. Total Reinforcing Items= **\$10,071.00**

SECTION IV- SPECIAL CONDITIONS, EXCLUSIONS AND/OR CLARIFICATIONS FOR THIS PROJECT

- Prices are based on a Start Date of not later than _____ and shall remain valid through _____. Any rebar shipped AND/OR installed after that date will be subject to an increase _____ /Ton every _____ months.
-
- **Sound Wall estimated at 104 L.F.****
- **Bus Duct Supports estimated as 15 Total.****
-
-
-
-
-
- Above prices based on NO RETENTION for contracts of \$50,000 or less.

SECTION V- CONTRACTOR TO PROVIDE AT NO COST TO SELLER

- 1 X All lines, grades, racks, forms, layout and rigid templates accurately in place before installation, except those forms or other materials that will hinder the installation.
- 2 X Firm, level, subgrade at elevation shown on drawings including all levels, datum lines, elevations, openings and dowel outs for concrete &/or masonry.
- 3 X Clear access roads & ramps for unloading of trailer/truck deliveries to within 50 feet of point of installation, and reasonable storage and lay-down areas.
- 4 X Cages for drilled piers, shafts, caissons, and light pole standards will be tied and stockpiled by Subcontractor.
- 5 X Suitable equipment fully operated for hoisting/lowering reinforcing steel, personnel, wire mesh, etc, including unloading trucks, staging of reinforcing to points of installation (into foundations, and onto elevated decks, etc) setting columns, wall cages and/or any other pre-tied assemblies including power placing of individual bars as required.
- 6 X Copies of all contract documents in quantities as reasonably requested.
- 7 X Parking area and/or cost of parking for field crews and provide area for jobsite office including utility hookup.
- 8 X Furnish design information, location of pour joints and construction schedules in sufficient time to allow for the preparation and approval of detail drawings plus a minimum of seven (7) working days for fabrication and delivery. 48 hours notice is required for cancellation of previously scheduled deliveries and two (2) weeks notice of job requirements.
- 9 X This proposal is based on pouring the walls and top slabs in all reinforced concrete box culverts monolithically.
- 10 X 24 hour notice for workman at jobsite and placement to be done on normal 8 hour shift excluding weekends and holidays.

SECTION VI- STANDARD EXCLUSIONS BY SELLER & FURNISHED BY BUYER

- 1 X Cost of inspections, crane inspections, testing, bonds, permits, penalties or Liquidated Damages.
- 2 X Inserts, sleeves, rubatex, water stops, smooth dowels and /or dowel baskets, galvanized or epoxy coated dowels, threaded rebar, stud rails and placing of stud rails.
- 3 X Cleaning, cutting, straightening, locating or rework of existing reinforcing steel, reinforcing extending from piles, or precast
- 4 X Cutting, drilling of holes, grouting, field bending or dry-packing of reinforcing steel.
- 5 X Burning, cutting, or drilling of structural steel/miscellaneous iron to pass reinforcing steel.
- 6 X Protection and/or cleaning of others work, covering, painting, greasing or wrapping of reinforcing steel or smooth dowels.
- 7 X Rebar Safety Caps or devices for covering rebar ends.
- 8 X All welding and rebar welded to structural/ miscellaneous iron.
- 9 X Blocking, chairing, wrapping and/or pulling of welded wire fabric.
- 10 X All dead men, cables, labor and engineering of system for guying of rebar, if required.
- 11 X Cleaning of tie wire clippings, tags and other spoils from work areas, cost of dumpster and composite crew cleanup, except as mutually agreed.
- 12 X Lines, grades, steel racks, templates, scaffolding, safety rails, work platforms & ramps, sanitary facilities and jobsite access to drinking water.
- 13 X Removal, grinding &/or patching of staples, nails, bolts and/or any other device used for the placement of concrete reinforcing accessories.
- 14 X Reinforcing for Anchor Points (and the Anchor Points) for Shotcrete, Precast, Closure Pours, Precast Connections and Prestressing Items.
- 15 X Sand Plated Chairs.
- 16 X Test bars and test couplers (except those specifically called out in specs)
- 17 X Adequate power and lighting when necessary.
- 18 X Cost of reworking or replacing reinforcing steel damaged or lost due to flood, actions of buyer, other subcontractors or other acts of God.
- 19 X Blocks, inspection tubes, wheels or spacers for clearances in drilled shafts or caissons.
- 20 X Tie wire, accessories and field placing aids for F.O.B. materials.
- 21 X Prevailing Wage Rates or Job Specific Labor Agreement Rates. Proposal based on Open Shop wages.
- 22 X Design Engineering, Engineer stamping of drawings, Field Measurements and As-Built drawings.
- 23 X Sitework, Masonry Rebar, Mock Ups, MSE Walls, Electrical Duct Bank, Equipment Pads, Pipe Encasement &/or Supports. (Unless specifically stated as included)
- 24 X Supply & Installation of reinforcing for stair landings and treads.
- 25 X Layout of TOW, TOF, EOW, expansion/construction joints, comers, doorways, blockouts and/or openings of any kind and Masonry Dowels.
- 26 X Separate Pour Watchman, Fire Watchman, Safety Manager, QC Mgr, Traffic Control or Onsite Security.
- 27 X Trim reinforcing for openings, penetrations, and inserts not specifically located on Structural Drawings.
- 28 X Double handling costs, including costs to transport material from an unreasonably located area.
- 29 X Unloading, handling &/or setting of FOB materials (including Prebuilt Drilled Shaft Cages).
- 30 X Dust control, Storm Water management and/or similar environmental programs.
- 31 X Third party invoicing processing fees or enrollment in third party invoicing services.
- 32 X Re-Detailing of shop drawings & reviewing/processing of changes will be at \$65.00/Hr.
- 33 X Build Information Modeling (BIM), 3D Modeling and similar, unless specifically stated otherwise.
- 34 X Non-standard work week and/or special work hours. (This bid proposal based on M-F, 8hr/workday, daylight hours, unless specifically stated otherwise.)

Tyler Reinforcing LLC
SECTION VII- TERMS AND CONDITIONS

PO Box 6520 Phoenix, AZ 85005, (602) 269-5900

- 1 **Terms of Sale: Payment Terms** – Subject to on-going credit approval: Net 30 days from date of invoice. Interest will be charged on all past due balances per the maximum rate allowed by law. Legal fees and costs will be paid as awarded to the prevailing party in the event of a legal dispute. Seller reserves the right to stop Work or demand security as required. Buyer agrees to pay Seller in accordance with the escalation policy as specifically identified in this proposal. "Work" is hereby defined as the performance of all work as listed above and included in any accepted Agreement, plus any changes, acceleration/out of sequence work, damages, escalation and costs incurred for the cause or benefit of Buyer or others.
- 2 **Acceptance:** Prices of individual bid items are subject to renegotiation if Buyer elects not to accept this complete proposal as presented. If Seller is requested to proceed with the work prior to the execution of a mutually agreed Contract, or if the work is completed prior thereto, the Terms and Conditions herein shall govern pending said Agreement. No assignment of this proposal shall be made without our prior written consent. We reserve the right to sublet portions of our Work.
- 3 **Schedule:** Seller's price is based upon detailing, fabrication, and placing on a normal 5-day, Monday to Friday, 40 hour work week, daylight hours unless explicitly noted on the face hereof. Performance will be based on bid documents as provided for tender and industry standards/CRSI. Schedule and schedule changes to be mutually agreed. Buyer to provide Seller (48) hours' notice of cancellation or modifications to schedule deliveries, Buyer agrees to provide adequate notice for workmen required at the jobsite and sufficient work for at least one full shift. Detailing submittals will be sequenced in a manner appropriate to the construction schedule. Working schedules to be made by mutual agreement of the Contractor and Subcontractor to conform to Contractor's master schedule. In event duration times are provided by Subcontractor, it is agreed that time starts only when work areas are provided ready to receive installation in all respects, in accordance with OSHA and State safety regulations.
- 4 **Back Charges/Shipping Discrepancies :** No charges for labor or materials furnished by the Buyer shall be allowed as a credit unless authorized in writing by Seller within ten (10) days of said occurrence. After a twenty four (24) hour period, all loads will be assumed to be verified.
- 5 **Safety:** Buyer will provide at no cost to Seller, general jobsite conditions conforming to OSHA standards and local governing authorities, including, but not limited to, adequate protection to ensure the safety of those working above reinforced steel as required, furnishing and installation of rebar safety caps or other OSHA compliant impalement hazard protection as required; Detection of/protection from underground and other utilities; Safe access, signage and other required warnings, flagging, barriers/barricades, general site and task lighting as required; Shoring, fall-protection anchorage points, walkways, approved scaffolding and staging in place as required, trenches, rails, snow and ice removal, all weather truck access; safe access to points of storage and work, etc. all as required.
- 6 **Insurance:** General Liability insurance will be provided solely for work performed by Seller and/or its engaged parties. Seller is not providing insurance for any liabilities that exceed Seller's responsibilities and/or liabilities. Additional Insured Endorsements may limit liabilities to those assumed under the Agreement and exclude Professional Liabilities. XCU, subsidence, Professional Liability, Aircraft, Pollution Liability and mold coverage are excluded as not applicable to this trade. Additional coverage or alternate requirements not set forth herein and mutually agreed are subject to availability and any additional costs. Seller excludes Builders Risk Insurance and return receipt requested notices for all certificates of insurance. Compliance requirements for any hired sub-subcontractors are subject to availability.
This bid proposal is based on Seller providing General Liability insurance of \$2,000,000.00 . Any additional coverage may result in additional costs.

SECTION VIII- CONDITIONS OF SALE EXCLUDED:

- 1 Pay if paid or "Pay when paid" conditions precedent for all properly completed work, including base scope of work, changes, acceleration/out of sequence work, damages, escalation and costs incurred for the cause or benefit of Buyer or others("Work"); Retention exceeding the rate withheld by Owner; Retention on F.O.B. items.
- 2 Indemnification, claim, and defense liabilities, responsibilities or damages exceeding any proportionate extent of cause by Seller's active negligence or willful misconduct.
- 3 Minority, DBE, DVBE, SBE, WBE and other special hiring status content, affiliation, or contribution to such requirements.
- 4 Risk, liabilities and responsibilities arising from existing conditions and preceding work exceeding visual inspection, including, but not limited to, field measurements, surveying, layout, forming and materials supplied by others; Costs arising from differing conditions and/or requirements from plans or drawings or bar lists provided for performance.
- 5 Design engineering and related Professional Liabilities and responsibilities; Costs and damages due to varying conditions and requirements.
- 6 Waiving any rights of dispute or redress; Costs/risks of claims against Owner for undisputed portions of our Work.
- 7 Forms and information requirements not mutually agreed; Unconditional forms of release in advance of receipt of funds; Releases that fail to exclude pending changes, unpaid balances, and retention as applicable; Releases for claims unrelated to payment for work performed; Non-conforming forms of waivers and releases within States that provide Statutory release language.
- 8 Reports, waivers, and other forms and contractual obligations related to bulk suppliers to our inventory stock who do not have lien rights.
- 9 Warranties exceeding Seller's scope of responsibilities or one (1) year; Guaranties of work performed by others; any forms of warranties, express or implied, of merchantability or fitness for purposes intended.
- 10 Risks and responsibilities for equipment and/or employees of Buyer or others providing services, or manning equipment used in connection with, but not within, Seller's scope of Work.
- 11 Liquidated and delay damages exceeding actual damages incurred, our scope of responsibility and/or our proportionate extent of cause, and for Force Majeure; Property damage, remedial work and/or replacement of Work and the work of others to the extent made necessary by others or Force Majeure.
- 12 Increased labor and material costs and/or damage in the event of project suspension or delay.
- 13 General Liability credits for any wrap-up insurance programs.
- 14 Prime contract terms, conditions, and scope in addition to, and/or in conflict with, a mutually agreed contract and Seller's scope of work and responsibilities as described herein.
- 15 Reports, submittals and data requirements not applicable to our trade, reasonably required or mutually agreed; Release of proprietary or other confidential information.
- 16 Any portion of fines or penalties exceeding the extent of cause by Seller; Any increased, surcharged or escalated portion of fines incurred by Buyer.
- 17 Enrollment/contributions to unions to which Subcontractor is not signatory; compliance with any additional or conflicting term, condition, or rate of pay, etc. between Seller's labor agreement and others affiliated with the Project.
- 18 Guarantors.
- 19 Site security.

SECTION X- ACCEPTANCE

The above proposal including all attached and referenced documents shall constitute a contract or shall be part of a contract is subject to on-going credit approval. Prices shown are for the complete project and NO single item price or group of prices are valid alone without the consent of the Seller. We reserve the right to modify/negotiate amendments to any Contractor issued forms of Agreement, as required to properly describe scope of work, pricing and mutually

Buyer: _____
By: _____
Title: _____ Date: _____

Seller: **Tyler Reinforcing LLC**
By: **Joel Byko**
Title: **Commercial Sales Manager** Date: _____



APL ACCESS & SECURITY, INC.

CARD ACCESS * BIOMETRICS * CCTV/IP VIDEO * NETWORK VIDEO RECORDING * INTRUSION DETECTION * ID BADGING
GATE ACCESS SYSTEMS * ELECTROMECHANICAL DOOR HARDWARE

Proposal: 10444-1-0
8/19/2019

Proposal For:

The Ashton Company
Patty Bitnar
2727 S Country Club Road, P.O. Box 26927
Tucson, AZ 85713
Phone: (520) 505-3561
Fax:
Email: pbitnar@ashtoncoinc.com

Prepared By:

Corey Morris - Estimating/Design
APL Access & Security-Tucson
3400 East Global Loop, Suite 170
Tucson, AZ 85706
Phone: (520) 294-9471
Fax: (520) 989-6009
Email: cmorris@aplsecurity.com

The Ashton Company
PC Tres Rios - GMP2 Project





APL ACCESS & SECURITY, INC.

CARD ACCESS * BIOMETRICS * CCTV/IP VIDEO * NETWORK VIDEO RECORDING * INTRUSION DETECTION * ID BADGING
GATE ACCESS SYSTEMS * ELECTROMECHANICAL DOOR HARDWARE

Proposal: 10444-1-0
8/19/2019

PC Tres Rios - GMP2 Project

The Ashton Company
Patty Bitnar
2727 S Country Club Road, P.O. Box 26927
Tucson, AZ 85713
Phone: (520) 505-3561
Fax:
Email: pbitnar@ashtoncoinc.com

APL Access & Security, Inc. shall provide the necessary tools, equipment and materials required to add (4) access control doors at Tres Rios WTF located at 7101 N. Casa Grande Hwy, Tucson, AZ 85743. This system is based in accordance with owner supplied specifications and drawings.

After careful consideration based on specifications for the system, we have assembled a system that meets current specifications and has the capability to be upgraded for future needs. A great deal of thought and analysis has gone into the selection process. Our first-hand experience with the various products available affords a unique opportunity to select proven products, which most closely reflect your needs. APL Access & Security, Inc. is please to provide the following proposal:

Description of Work/Labor

This Proposal covers labor & materials needed to add (4) Access Control doors.

APL WILL:

Access Control Doors

- Run wire from door locations to HE
- Install Card Reader, Door hardware, Transfer Hinge, REX Switches, and Door Contacts
- Terminate all wires
- Test for proper operation

HE

- Install DSX Panels in HE
- Terminate all wiring

Supplied by Others:

- 120VAC for Access Control Panels
- IP Address for Access control Panel
- Network Switch with available ports
- Lock Cores for Von Duprin Trims
- Mullion for Double doors
- Programming of new doors
- Conduit to door locations (if required)





APL ACCESS & SECURITY, INC.

CARD ACCESS * BIOMETRICS * CCTV/IP VIDEO * NETWORK VIDEO RECORDING * INTRUSION DETECTION * ID BADGING
GATE ACCESS SYSTEMS * ELECTROMECHANICAL DOOR HARDWARE

Proposal: 10444-1-0
8/19/2019

PROJECT ESTIMATE

Schedule of Equipment for: Access Control \$16,775.53

QTY	Manufacturer	Part #	Description	Unit Price	Ext. Price
1	DSX	DSX-1042PKG	Intelligent 2 Door Package - Includes 1 1040E	\$1,165.91	\$1,165.91
1	DSX	DSX-LAN	Auto-sensing 10/100BaseT communications Interface	\$240.58	\$240.58
1	DSX	DSX-SWS150/28	LPS 110VAC to 27V 5.5A, 150 Watt LP 24V Locks	\$122.14	\$122.14
1	DSX	DSX-1042	Intelligent Two Door I/O Controller	\$732.86	\$732.86
5	Von Duprin	QEL99EO US26D 3	Electrified Exit Device	\$1,560.18	\$7,800.90
5	Von Duprin	050251 CON	RX S1 Switch Kit Request to Exit Switch 22/33A/35A	\$166.79	\$833.95
5	Marray	TEF2+4C US26D	Standard Hinge 4.5 X 4.5 Satin Finish	\$124.62	\$623.10
4	HID	920PTNNEK0000	6125CGN0000-1453: Reader, RP40 Multi-ClassUniversa	\$215.06	\$860.24
4	Von Duprin	996L-06-R/V US26D	Lever Trim	\$596.09	\$2,384.36
1	1LOT	1Lot	Lot: All necessary cable, fasteners, connectors, mounting hardware, cam-locks and misc consumables.	\$2,011.49	\$2,011.49

Schedule of Equipment for: Chargeable Items \$11,770.81

QTY	Manufacturer	Part #	Description	Unit Price	Ext. Price
3	Windy City Wire	444351	Cable, 22-06, Shielded, Stranded, Plenum, White	\$254.77	\$764.31
3	Windy City Wire	444381	Plenum, 4C, 22G, STR, Nonshielded, 1k per	\$131.27	\$393.81
3	Windy City Wire	444366	22-02 UnShielded Stranded Plenum White/Green	\$93.57	\$280.71
3	Windy City Wire	442360	Cable, 18-20, UnShielded, Stranded, Plenum White	\$138.25	\$414.75

Labor Schedule for: Chargeable Items

QTY	Description	Unit Price	Ext. Price
1	Labor	\$6,800.00	\$6,800.00

Supplies and Materials for: Chargeable Items

QTY	Description	Ext. Price
1	Sales Tax Surcharge	\$1620.73
1	Shipping & Handling	\$296.5
1	Project Management	\$1200

Financial Summary

Total Proposal Amount \$28,546.34



115 SOUTH WILLIAM DILLARD DRIVE * GILBERT, ARIZONA 85233 * PHONE 48779471 * (262) 873-2288 * FAX (482) 4979971

WWW.APLSECURITY.COM

RCC#202588 * SOB CERTIFIED * SSA SCHEDULE 84 * UL 2050 CERTIFIED * MBE CERTIFIED * SBE CERTIFIED * DBE CERTIFIED

CONFIDENTIAL AND PROPRIETARY





APL ACCESS & SECURITY, INC.

CARD ACCESS * BIOMETRICS * CCTV/IP VIDEO * NETWORK VIDEO RECORDING * INTRUSION DETECTION * ID BADGING
GATE ACCESS SYSTEMS * ELECTROMECHANICAL DOOR HARDWARE

Proposal: 10444-1-0
8/19/2019

Provided by: The Ashton Company

- 120 VAC Power where necessary

WARRANTY: APL Access & Security, Inc. warranties all material and labor furnished for a period of one year from date of acceptance of project by Owner's representative. Warranty becomes void if serviced by an alternative company. Various preventative maintenance and extended warranty programs are available. Warranty does not include: vandalism, abuse, acts of nature, or other damage caused by guests, employees, contractors, or vendors. Routine warranty service response shall be from 8:00AM to 5:00PM Monday through Friday excluding holidays. After hour service rates shall be billed at current after hour/emergency rates.

COMPLETION AND PARTIAL COMPLETION WORK: At any time during the installation of this project, if APL Access & Security, Inc. completes a usable unit or portion of the work, the occupancy of which will benefit the Owner, APL Access & Security, Inc. may request the Owner to make final inspection of that unit. If the Owner finds upon inspection that the work has been satisfactorily completed in compliance with the Contract, it will be considered completed. Progress payment schedule shall apply to all completed work.

The completed system shall be tested in the presence of the owner's representative. Test forms shall document the results of the test and be signed by both parties. When the final system acceptance test has been satisfactorily completed, the owner shall sign a Letter of Completion issued by APL Access & Security, Inc.. APL Access & Security, Inc. shall record the notice of completion as the start of the 1-year warranty period. Owner's decision to use or not use the system at this time does not affect the warranty period.





APL ACCESS & SECURITY, INC.

CARD ACCESS * BIOMETRICS * CCTV/IP VIDEO * NETWORK VIDEO RECORDING * INTRUSION DETECTION * ID BADGING
GATE ACCESS SYSTEMS * ELECTROMECHANICAL DOOR HARDWARE

The Ashton Company
Patty Bitnar
2727 S Country Club Road, P.O. Box 26927
Tucson, AZ 85713
Phone: (520) 505-3561
Fax:
Email: pbitnar@ashtoncoinc.com

Proposal: 10444-1-0
8/19/2019

ACCEPTANCE

Proposal Summary

Project: PC Tres Rios - GMP2 Project
Total Cost: \$28,546.34

PAYMENT TERMS:

APL Access & Security, Inc. reserves the right to require progress billing as necessary for a project. All sums paid shall be sent to APL Access & Security, Inc. 115 South William Dillard Drive, Gilbert, Arizona 85233. APL Access & Security, Inc. reserves the right to charge interest for any invoice over 45 days old. The interest rate charged will be the full amount allowed by law.

30 day net. Prices are good for 90 days. All above equipment is property of APL until final payment has been rendered. In the event of non-payment, APL has the right to exercise any reasonable legal actions arising from such non-payment. The proposal provided represents our interpretation of the requirements of this project. Please feel free to contact us at the number below should you need clarification or if you simply have a question, as we are prepared to meet with you at your convenience.

We look forward to the opportunity to serve your business. Thank you in advance for your time and consideration.

Corey Morris

8/19/19

Estimating/Design
Corey Morris

Date

Signature, Print Name, and Title
Authorized Representative of: The Ashton Company

Date



115 SOUTH WILLIAM DILLARD DRIVE * GILBERT, ARIZONA 85233 * (520) 497-9471 * (520) 503-2552 * FAX (520) 497-9371

WWW.APLSECURITY.COM

ISO 9001:2008 CERTIFIED * ISO 14001:2004 CERTIFIED * OSHA SCHEDULE 80 * UL 2050 CERTIFIED * NBB CERTIFIED * SBE CERTIFIED * DBE CERTIFIED



CONFIDENTIAL AND PROPRIETARY



APL ACCESS & SECURITY, INC.

CARD ACCESS * BIOMETRICS * CCTV/IP VIDEO * NETWORK VIDEO RECORDING * INTRUSION DETECTION * ID BADGING
GATE ACCESS SYSTEMS * ELECTROMECHANICAL DOOR HARDWARE

Proposal: 10444-1-0
8/19/2019

1. EQUIPMENT

APL agrees to maintain the equipment for PC Tres Rios - GMP2 Project provided and installed by APL under the security system project for proposal 10444-1-0 in accordance with the terms and conditions of this Agreement. Note: Parts will be kept in-hand for Advanced Replacement, equipment replaced throughout the term could later become discontinued from the manufacture and require to be substituted with an equivalent.

2. INSPECTION AND REPAIR

Prior to the Commencement Date of maintenance under this Agreement, the Equipment shall be subject to inspection, at no charge to the Customer, by APL to determine if it is in acceptable condition for maintenance under this Agreement.

APL shall notify Customer of any repair or adjustments it deems necessary to bring the Equipment up top an acceptable condition for maintenance under this Agreement. Upon written authorization of Customer, APL shall have no obligation to perform the maintenance services contemplated by this Agreement.

3. TERM

The initial term of this Agreement shall be for a period of from the date of the end of the one year standard warranty or substantial completion, whichever comes first, for the completion of the above stated project. Thereafter, this Agreement shall continue in effect unless and until it is cancelled by either party upon thirty (30) days written notice.

4. CHARGES

a) The Customer shall pay APL for Maintenance Service provided hereunder upon submission of an invoice for the designated billing cycle, the total of the Monthly Maintenance charges set forth for each unit of the Equipment plus any Extended Maintenance and/or Remote Location Charges. Customer shall be considered in default hereof unless payment is made within thirty (30) days after receipt of APL's invoice. Charges shall commence as to each such unit on the date specified. Charges for any fraction of a month shall be apportioned.

b) Any charges not covered under subparagraph (a) shall be payable upon submission of bills therefore.

c) Customer shall also pay or reimburse APL for any and all sales taxes, use taxes, excise taxes, property taxes, and other fees, excise or charges levied or imposed by any government or agency or authority on it in connection with or measured by the Maintenance Service provided hereunder, the parts furnished or used pursuant hereto, or any or all of them; provided however, that the Customer shall not be liable for any income taxes levied or imposed upon APL's net income.

5 SPACE AND FACILITIES

If required, customer shall provide, at it's expense, adequate storage space convenient storage for APL's tools, supplies, equipment, and/or spare parts, and adequate working space including heat, light, ventilation, electric current, and outlets for use by APL's maintenance personnel.

6 UNAUTHORIZED RELOCATION, MODIFICATION, OR REPAIRS.

Customer shall not perform or authorize the performance of any repairs other than those listed in Paragraph 6 without APL's prior approval and shall not relocate, reinstall, or modify any of the equipment without APL's prior written approval. Service by anyone other than APL will default this Agreement.

7 DEFAULT.

Any of the following events constitutes a default of this agreement:

- a. Failure to make any payment when due hereunder.
- b. Failure of customer to cure the breach of any other obligation within thirty (30) days after written requests or demands, or
- c. Insolvency of the customer or if customer should become a party to any bankruptcy or receivership proceeding or make a general assignment for the benefit of creditors.

On customer's default, APL, at it's sole option can and may exercise concurrently or separately any and or all of the following remedies, (i) declare due and payable all applicable charges due, (ii) suspend performance, (iii) terminate this agreement, and/or (iv) pursue any and/or all remedy or remedies at law or in equity.

8 TERMINATION.

This agreement shall automatically terminate in the event that loss or irreparable damage or destruction occurs which renders the equipment permanently disabled or otherwise unfit for use.

9 EXCUSED NON-PERFORMANCE

APL shall not be liable for, and customer shall have no right to, and hereby waives and releases, any claim, demand, obligation, action, cause of action, damage, loss of service, expenses, and compensation of any nature, including but not limited to incidental and consequential damages, with respect to any delay in performance or the non-performance of any term or condition of this.



APL ACCESS & SECURITY, INC.

CARD ACCESS * BIOMETRICS * CCTV/IP VIDEO * NETWORK VIDEO RECORDING * INTRUSION DETECTION * ID BADGING
GATE ACCESS SYSTEMS * ELECTROMECHANICAL DOOR HARDWARE

Proposal: 10444-1-0

8/19/2019

Agreement, directly or indirectly resulting from fire, explosion, accident, flood, labor trouble, or shortage, or any government agency, or act of God. Customer's denial to APL of full and free access to Equipment, inability to obtain or shortage of suitable material (s), components parts, equipment, machinery, fuel, power, or transportation, or act of God or any other causes beyond APL's control.

10 MODIFICATION

This Agreement may be modified, amended, or revised only by written instrument duly executed by the parties hereto.

11 MISCELLANEOUS.

(a) EXCEPT AS EXPRESSLY SET FORTH HEREIN, THERE ARE NOT REPRESENTATIONS OR WARRANTIES EITHER EXPRESSED OR IMPLIED, AS TO MERCHANTABILITY, OR FITNESS FOR AN INTENDED PURPOSE, BEYOND THOSE PROVIDED BY ANY APPLICABLE EQUIPMENT MANUFACTURER, WHOSE EQUIPMENT IS INSTALLED BY CUSTOMER OR APL.

(b) No delay or failure of either party in exercising any or all rights hereunder and no partial or single exercise thereof shall be deemed to constitute a waiver of such right or any other rights hereunder.

(c) This agreement may not be assigned or in any other way transferred, sold, or distributed by the customer without the prior written consent of APL and any non-permitted assignment, transfer, sale, or distribution shall be void.

(d) Section headings are included for convenience only and are not to be used or construed or interpret this Agreement.

(e) This Agreement shall be construed and enforced in accordance with, and the validity and performance hereof shall be governed by the laws of the State of Arizona.

(f) This Agreement as well as any and/or all riders attached hereto signed by the parties to this Agreement with respect to furnishing of Maintenance Service for the equipment and shall be binding upon such successors and assigns of the parties hereto as are permitted hereunder.

(g) Any notice, request, order, or demand required or permitted to be given under this Agreement to either party shall be in writing and shall be sent through the United States Mail, addressed to the customer listed, and to APL. Attention office of the Secretary, or to such other addresses as the parties may, from time to time, designate in writing.

(h) Customer represents that he or she is the owner of the Equipment, or if not the owner, that he or she has authority to enter into this Agreement.

(i) APL retains the right to subcontract any Maintenance service described herein to subcontractor(s) of APL's choosing, including but not limited to, the Equipment manufacturer, provided that such subcontractor(s) shall possess qualifications equivalent to those of APL Access & Security, Inc.

CANYON FENCE COMPANY, INC.

850 East 98th Street
 Tucson, Arizona 85713-4803
 (520) 623-4800 Fax (520) 623-7895

AGREEMENT

REMIT TO:
 P.O. BOX 7546
 Tucson, AZ 85725-7546

LIC ROC # C-14-85713-010
 ROC # L-14-8573160-007

PHONE	DATE 10-14-19	JOB NO.
FAX	ATTN: ELLA	SALESMAN: SON

TO THE ASHTON CO

JOB ADDRESS BIOGAS PROJECT CITY JVL STATE AZ ZIP _____

NEAR _____

BILLING ADDRESS (if different) _____ CITY / ZIP _____

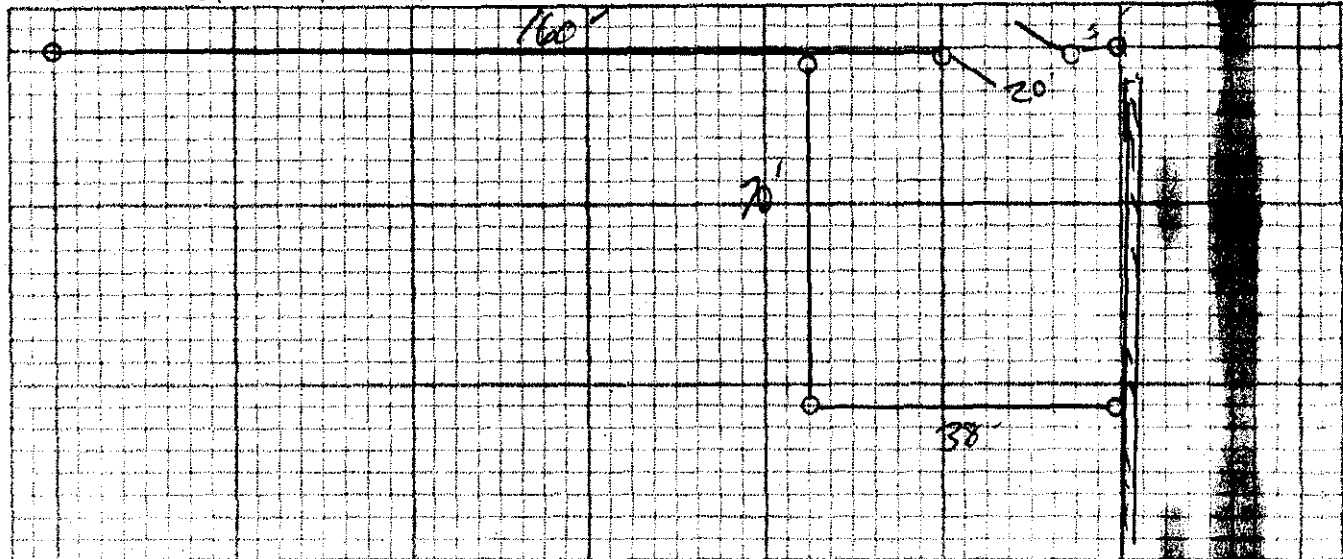

SPECIAL TOOLS: JACKHAMMER CORE DRILL AIR DRILL
 CLOSERS: KS SPRING
 SPECIAL INSTRUCTIONS: REMOVAL OF OLD FENCE
 OTHERS: BY OTHERS

CHAIN LINK FENCE										GATES								
Fig.	Hgt.	Gauge Fabric	Line Posts O.D.	Line Posts Spaced	Top Rail	Barbs Up	No. Down	No. Strs.	Up	Out	In	No. Sgl.	No. Dbl.	No. Roll	Width	Height	CL Frame	Style
273	74	9	2 3/8	10	1 5/8	2		3		X				1	20 X 74	1 1/8		

WOOD FENCE							WROUGHT IRON						
Fig.	Height	Line Post O.D.	Line Post Spaced	Top Rail	Middle Rail	Bottom Rail	Pickets	Fig.	Hgt	Spaced	Top Rail	Bottom Rail	Pickets
				X	X	X	X				X	X	
				X	X	X	X				X	X	
				X	X	X	X				X	X	

POSTS			BRACE TYPE		SLATS		SAFETY BARRICADE RAILING						
No.	O.D. or Size	Type			TYPE		Fig.	Hgt	No. Rails	Ln. OD	Post Spc.	OD-Rail	Out
	2 1/8												
	2 3/8												
	4"												

REMOVAL HAULING BLUE STAKE # _____

BUYER MAY CANCEL THIS TRANSACTION AT ANY TIME PRIOR TO MIDNIGHT OF THE THIRD BUSINESS DAY AFTER THE DATE OF THIS TRANSACTION. SEE THE ATTACHED NOTICE OF CANCELLATION FORM FOR AN EXPLANATION OF THIS RIGHT.

PLEASE READ THE TERMS ON THE REVERSE SIDE WHICH ARE A PART OF THIS AGREEMENT.

FOR THE SUM OF	\$
TAX	\$
TOTAL	\$ 7963.00
DOWN PAYMENT	\$
BALANCE DUE	\$

SELLER: CANYON FENCE COMPANY, INC.
 Submitted by _____
 Accepted by _____
 (Officer of Seller)

Buyer(s) _____
 By _____
 By _____

CANYON FENCE COMPANY, INC. IS NOT RESPONSIBLE FOR ANY DAMAGE TO UNDERGROUND SPRINKLER OR UTILITY LINES

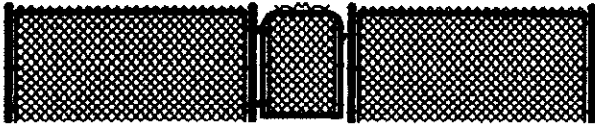

BIOGAS PROJECT

CANYON FENCE CO. INC.
PO BOX 7546
TUCSON, ARIZONA 85725
(602) 623-4800

CHAINLINK FENCE SPECIFICATION

FABRIC: 84" 9 GA. GALVANIZED (2" Mesh) CHAIN LINK FABRIC.

TOP RAIL: 1 5/8" O.D. DQ-40 PIPE, 1.83 lbs. per foot. Top rail 21' in length, joined with 1 5/8" SLEEVE.

LINE POST: 2 3/8" O.D. DQ-40 PIPE, 3.12 lbs. per foot. Line posts set 10' on center maximum spacing. Concrete footing: 12" diameter, 36" depth.

TERMINAL POST: 2 7/8" O.D. DQ-40 PIPE, 4.47 lbs. per foot. Concrete footing: 12" diameter, 36" depth.

BRACING: Terminal posts braced and trussed to the nearest line post with 1 5/8" O.D. DQ-40 PIPE and 3/8" TRUSS ROD & TRUSS ROD TIGHTENER.

GATES: Framework of 1 7/8" CQ-20 PIPE, 1.76 lbs. per foot. Gates braced and trussed as necessary. Same fabric as fence. Barbed wire included on all gates.

GATE POST: 4" O.D. FULL WEIGHT PIPE, 9.10 lbs. per foot. Concrete footing: 12" diameter, 36" depth.

TENSION WIRE: 7 GA. COIL SPRING GALVANIZED TENSION WIRE attached to bottom of fence fabric with 12 GA. STEEL HOG RING spaced 24" on center.

BARBED WIRE: 4 strands of 12 1/2 GA. 4 PT. GALVANIZED BARB WIRE on 45 Deg. PRESSED STEEL BARB WIRE ARM.

FITTINGS: REGULAR BRACE BAND & CARRIAGE BOLT, PRESSED STEEL RAIL-END, 45 Deg. PRESSED STEEL BARB WIRE ARM, PRESSED STEEL CAP, 3/16" X 3/4" TENSION BAR, REGULAR TENSION BAND & CARRIAGE BOLT.

TIE WIRE: 10 1/2" 12 GA. STEEL TIE WIRE & 8 1/4" 12 GA. STEEL TIE WIRE spaced 15" on center for line posts & 24" on center for rails.

POST FOOTING: HAND MIXED CONCRETE.

ARIZONA ELECTRIC SUPPLY

ARIZONA ELECTRIC SUPPLY
 3310 E. GAS RD #100
 TUCSON AZ 85714

TEL: 520 622-7751 FAX: -

CONTACT: TONY @ ARIZONA ELECTRIC SUPPLY

QUOTE FOR: THE ASHTON COMPANY 0510 X45

ACCT #: JJ-86750 THE ASHTON COMPANY INC

PO BOX 26927
 TUCSON, AZ 85726
 TEL: (520) 624-5500

QUOTATION		PAGE	
QUOTE #	DATE	REV #	REV DATE
1025642	08/20/19	005	10/11/19
QUOTE EXPIRES		PREPARED BY	
09/19/2019		TC	
SLS		INSL	
1654		1654	
FOB		FREIGHT	
SHIPPING POINT		PREPAID	

CUS PO #:
JOB NAME:
TRES RIOS GMP 2

LN	QTY	MFR	CATALOG #	DESCRIPTION	PRICE	UOM	EXT AMT
01				ORIGINAL QUOTE WITH COPPER WINDINGS			
02	1		EATON LOT GEAR	SEE PAGES 1 THRU 7	585,700.00	E	585,700.00
03	*						
04	2	X	S & C SWITCHES	SEE PAGE 8	28,800.00	E	57,600.00
05	*						
06	*			REVISED PER SPECS CHANGING MCC & MED VOLTAGE GEAR			
07	*			& PRICE INCREASE			
08	1		EATON LOG GEAR		595,300.00	E	595,300.00
09	*						
10	2	X	S & C SWITCHES		28,800.00	E	57,600.00
11							
12	*			REVISED TAKING OUT EXPLOSION PROOF DISC'S &			
13	*			CHANGING THEM TO NEMA 4X			
14	1		EATON LOT GEAR	SEE PAGES 1 THRU 9	577,000.00	E	577,000.00
15	*						
16	2	X	S & C SWITCHES	SEE PAGE 10	28,800.00	E	57,600.00

TOTAL: 1,930,800.00

PLEASE NOTE: THIS IS NOT AN OFFER TO CONTRACT, BUT MERELY A QUOTATION OF CURRENT PRICES FOR YOUR CONVENIENCE AND INFORMATION. ORDERS BASED ON THIS QUOTATION ARE SUBJECT TO YOUR ACCEPTANCE OF THE TERMS AND CONDITIONS LOCATED AT SALES.OUR-TERMS.COM, WHICH WE MAY CHANGE FROM TIME TO TIME WITHOUT PRIOR NOTICE. WE MAKE NO REPRESENTATION WITH RESPECT TO COMPLIANCE WITH JOB SPECIFICATIONS.



Detail Bill of Material

Project Name: Pima County Tres Rios Gas Upgrading System
 General Order No:

Negotiation No: TU700805X9K3
 Alternate No: 0003

Item No.	Qty	Product	Description
1		EESS SAT	<p>***See Approval Drawings for Comments and Clarifications*** Start-up Contact: Contractor Kevin 5209094795 Estimated Start-up Date: 03-31-2020 A Coordination Study does exist. It was performed by Eaton</p> <p>Designation Commissioning Training</p> <p>Qty List of Materials</p> <ul style="list-style-type: none"> 1 EESS Office: Phoenix, AZ 1 Jobsite: Ina Road WWRF, Tucson, Arizona 85743 1 Drive Time: 1.38 Hours 1 NETA Standard Scope of Work 1 Weekly Site Schedule: 8 hr Days, 5 Days per Week 1 Thermographic Scan 8 Hours Customer Training Provided by EESS 8 Hours Site Specific Training Time for EESS Personnel 1 Dry Type Transformer 1 Pow-R-Line1a 4 Power Transformers 7 Safety Switches 1 Ampgard MVC 1 MVS 5/15 kV Lineups 1 Freedom MCC 1 Multiple Site Trips per specification 1 Hrs Office Time 1 Hrs On Site Standard 1 Hrs Travel 1 Per Diem 1 Expendable Supplies 1 Mileage

Item No.	Qty	Product	Description
1		EESS Services	<p>EESS Short Circuit and Coordination Studies: Arc Flash Hazard Analysis, Arc Flash Labels - Standard, PE Review / Stamp Required - Arizona</p> <p>***See Approval Drawings for Clarifications and Exceptions*** JON LOCKHART</p> <p>Designation STUDY</p> <p>Qty List of Materials</p> <ul style="list-style-type: none"> 1 ESS Study-BidManager 1 2 Weeks Lead Time for Data Request Submittal 1 4-6 Weeks Lead Time for Study Completion 1 Quoted by Bid Manager 1 PE Review Stamp Required (Arizona) 1 Arc Flash study 1 Arc Flash Labels - Standard

Item No.	Qty	Product	Description
1		Medium Voltage Switches	Outdoor, 5kV Max, 4.16kV system, 3 wires, Tin-Plated Copper bus, 1 Structures



Detail Bill of Material

Project Name: Pima County Tres Rios Gas Upgrading System
 General Order No:

Negotiation No: TU700805X9K3
 Alternate No: 0003

Designation 87-MVDS1

- | Qty | List of Materials |
|-----|--|
| 1 | Outdoor Enclosure |
| 1 | Copper tin plated bus |
| 1 | 5kV Switch 600A, 61kA mom, 61kA fc |
| 1 | Set of Current Limiting - E Rated, CLE 250 Amp max fuses |
| 1 | CLE 5 KV Disconnect fuse mounting |
| 1 | Visual blown fuse indication |
| 1 | Spare set of Current Limiting - E Rated, CLE 250 Amp max fuses |
| 1 | Total Freight Price |

Item No.	Qty	Product	Description
	1	Medium Voltage Control	Ampgard Medium Voltage Motor Control, NEMA 1A (w/Gasketing), 4160V, 60 Hertz, 1200 Amps Main bus.

Designation 87-SWGR-01

- | Qty | List of Materials |
|-----|--|
| 3 | Character Color/Nameplate Color - Black on White |
| 1 | System BIL is 60kV |
| 1 | Control Wire Designation: Wire number only |
| 3 | Control Wire Marker - Sleeve Type |
| 1 | Equipment Rated to work at 40C, 3281FT (1000 M) |
| 2 | 4" Filler |
| 2 | Transition Compartment |
| 3 | Standard Structure |
| 5 | NEMA 1A (w/Gasketing) |
| 5 | 4160V 60Hz 1200A Copper Main Bus, 50ka for 2sec Bracing |
| 5 | Tin Plated Copper Bus, Complete Bus |
| 1 | 400A FLA 52-89, Ampgard MV4S Soft Start.NR RO |
| 1 | Motor cable distance must be <= 700ft 1 cable per phase or 350ft for 2 cables per phase |
| 1 | 2KVA CPT RVSS STD |
| 1 | Control Voltage 120VAC |
| 1 | Load Cable Entry Bottom |
| 1 | Remote Start/Stop Push Buttons Control Circuit |
| 1 | Main Contactor Drop Out Time 130ms |
| 1 | To maintain the warranty, startup from an Eaton Certified Specialist is required for MV4S RVSS and is not included in this quote |
| 1 | Starter Isolation Switch |
| 1 | Current Limiting Power Fuses |
| 1 | Current Transformers |
| 1 | 3 PHASE PT |
| 1 | Main Contactor Roll-In/Roll-Out |
| 1 | Bypass Contactor Roll-In/Roll-Out |
| 1 | 4160V MV4S 400A RVSS |
| 1 | Low Voltage Control Compartment |
| 1 | Set of Control Circuit Terminal Blocks |
| 1 | Interposing Relay 3NO 1NC |
| 1 | Interposing Relay 2NO 2NC |
| 2 | Misc. Indicating Light, LED |
| 1 | Reset Pushbutton |
| 1 | CT SCTB |
| 1 | Misc 2 Pos Selector Sw |
| 1 | Lightning Arrestors, Intermediate Class |
| 1 | 30mm (E34) Start/Stop Pushbutton |
| 1 | PX6000 (no display) |

Detail Bill of Material

Project Name: Pima County Tres Rios Gas Upgrading System
General Order No:

Negotiation No: TU700805X9K3
Alternate No: 0003

- 1 PX Meter 12" color touchscreen display
- 1 Hand/Off/Auto Selector Switch
- 1 30mm (E34) Red Run/Close Indicating Light, LED
- 1 30mm (E34) Green Off/Open Indicating Light, LED
- 1 EMR5000 Modbus/DNP3 RTU over RS-485 or Modbus/DNP3 TCP 16in/9out 2AI/2AO
- 1 Solid State RV Auxiliary Cell
- 2 Auxiliary Structure 10 to 30" wide
- 6 Blank Auxiliary Compartment
- 2 AUX Disconnect Switch Compartment
- 2 Main Breaker 1200 Amp/50 KA 3 Cycle
- 2 Breaker Control Switch
- 2 30mm (E34) Red Indicating Light, LED
- 2 30mm (E34) Green Indicating Light, LED
- 2 Lightning Arrestors, Dist. Type
- 2 Capacitor Trip
- 2 Powerware UPS
- 2 Line Source AC 2KVA CPT
- 2 Capacitor Trip
- 2 50:5 GFCT
- 2 1st Set Load CT, Normal Accuracy, Multi-Ratio - 500/5 MR (C200)
- 2 1st Set Line CT, Normal Accuracy, Multi-Ratio - 500/5 MR (C200)
- 1 Total Freight Price

Item No.	Qty	Product	Description
	1	Power Transformers	Power Transformer, 2, 72216 - Cooper Liquid Filled Padmount, 750 KVA
		Designation	87-TX-01A
		Qty	List of Materials
	1		Tamper-Resist, Pad Mount, HTH Filled, Copper Windings 750KVA

Item No.	Qty	Product	Description
	1	Power Transformers	Power Transformer, 2, 72216 - Cooper Liquid Filled Padmount, 750 KVA
		Designation	87-TX-01B
		Qty	List of Materials
	1		Tamper-Resist, Pad Mount, HTH Filled, Copper Windings 750KVA

Item No.	Qty	Product	Description
	1	Power Transformers	Power Transformer, 2, 72216 - Cooper Liquid Filled Padmount, 750 KVA
		Designation	87-TX-02A
		Qty	List of Materials
	1		Tamper-Resist, Pad Mount, HTH Filled, Copper Windings 750KVA

Item No.	Qty	Product	Description
	1	Power Transformers	Power Transformer, 2, 72216 - Cooper Liquid Filled Padmount, 750 KVA

Detail Bill of Material

Project Name: Pima County Tres Rios Gas Upgrading System
General Order No.:

Negotiation No.: TU700805X9K3
Alternate No.: 0003

Designation 87-TX-02B

Qty List of Materials

1 Tamper-Resist, Pad Mount, HTH Filled, Aluminum Windings 750KVA

Item No.	Qty	Product	Description
1		Motor Control Centers	60 Hz, Class 1B wiring, 480V 3-Phase Service, 65,000 Bracing, Short Circuit Rating, Bottom Incoming, NEMA 12 Dust tight 21" Front Mt Only enclosure, 1200A Copper Main Horizontal Bus, No Neutral, Main Breaker. Used X-Space: 73, Blank X-Space: 11, Future X-Space: 0, MCC Lead Time Code: U.

Designation 87-MCC-01

Qty List of Materials

2 PXM2270 METER/DISPLAY 60HZ 5A 90-265V AC/DC
 2 NGH Main Bkr (800A trip), Lugs: 4-#4/0-500Kcmil
 2 PXM2270
 4 600V Potential transformer
 6 800A Current transformer
 5 FVNR Starter Size 2 [HMCP]
 1 FVNR Starter Size 5 [HMCP]
 1 IT Soft Start S811 Non-Communicating, 180 Amp, Standard Duty, [HMCP]
 1 SVX VFD, Variable torque, 16 FLA, 480V, HMCP
 1 HFD Bkr (125A trip)
 1 HFDTwin Bkr (15A /15A trip)
 1 250VA Individual CPT, Fused
 1 350VA Individual CPT, Fused
 5 100VA Individual CPT, Fused
 5 150VA Individual CPT, Fused
 2 N.C. Starter Aux Contacts, Size 5-6
 10 N.O. Starter Aux Contacts, Size 1-4
 10 N.C. Starter Aux Contacts, Size 1-4
 2 N.O. Starter Aux Contacts, Size 5-6
 8 Terminal Block - Latching Pull-Apart, Std.
 7 Pilot Light-PTT-10250T-LED (Run)
 1 1. HOA, Fwd-Rev-Stop PBs, Fwd-Rev-Stop Lights, Output Reactor
 6 Solid State Overload Relay (Advanced C441)
 8 Wiremarkers at Each End
 7 Pilot Light-PTT-10250T-LED (Stopped)
 8 #14awg, MTW Control Wire
 1 1. HOA, Start-Stop PBs, Run-Stop Lights, Output Isolation Contactor
 1 IT Soft Start 120V Interface & 100VA CPT
 8 1 N.O. - 1 N.C. Aux Circ Bkr Sw.
 8 Panel Elapsed Time Meter (Standard)
 8 Pilot Light-PTT-10250T-LED (Overload Trip)
 1 Pilot Light-PTT-10250T-LED (Off, Stopped)
 1 Pilot Light-PTT-10250T-LED (On, Run, Fast, Forward)
 8 3 Pos. Sel. Sw., 10250T (Hand-Off-Auto)
 8 2 Unit PB, 10250T (Start/Stop)
 2 Main Bkr Mechanical Key Interlock
 2 Service Entrance Label
 2 RMS 310+ ALSIG Trip w/ GF
 1 Speed Pot 1000 Ohm
 1 160KA, SPD Standard + Surge Counter Features Package, with Circuit Breaker
 4 12" Door
 3 6" Door



Powering Business Worldwide.

Detail Bill of Material

Project Name: Pirna County Tres Rios Gas Upgrading System
General Order No:

Negotiation No: TU700805X9K3
Alternate No: 0003

- 7 Structure Floor Leveling Channel Sills
- 7 Structure Bottom plates Included with NEMA 12
- 7 600A Vertical Bus (Tin-plated cu)
- 7 600A Horiz. Cu Gnd Bus, 1/4" x 2" Bar
- 7 Labyrinth, Isolated/Insulated vertical bus barrier with shutters
- 7 65KA Bus Bracing
- 7 Tin Plated horizontal bus
- 7 1200A Copper Frnt Mtd 21" N12 Dust Tight
- 2 Blue beacon light top of main breakers tied to ARMS

Item No.	Qty	Product	Description
	1	Panelboards	30 Circuits, 225A, Fully Rated, 208Y/120V 3Ph 4W, Tin Plated Copper Bus, 10k AIC, 225A, 3P EDB Main Breaker[Top Fed], Surface Mounted

Catalog No P1A225BT30TH01
Designation 87-PNL-01

Qty List of Materials

- 1 225A, 3P EDB Main Breaker
- 1 Optional F Frame Terminal, (1) #6-300 kcmil
- 14 20A, 1P BAB Branch Breaker
- 1 15A, 1P BAB Branch Breaker
- 1 60A, 2P BAB Branch Breaker
- 4 15A, 2P BAB Branch Breaker
- 2 1P BAB Branch Provision Only
- 1 60A, 3P BAB-H Branch Breaker
- 1 Surge Protective Device, 120 kA SPD Series - Standard w/ Surge Counter
- 1 Tin-Plated Copper Main Bus, 225 Amps
- 1 Std. Bolted Cu Ground Bar (Cu Cable Only)
- 1 Panel Nameplate - White with Black Letters
- 1 Type 1 Enclosure: EZB2048R
- 1 EZ Trim, Door in Door, Concealed Hardware: EZT2048S

Item No.	Qty	Product	Description
	1	Dry Type Transformers	Transformer Type: General Purpose Vented

3 Phase, 75 KVA,
1 K-Factor
480 Primary Volts
208Y/120 Secondary Volts
Temperature Rise 150C with 220C Insulation System
Copper Winding Material
Sound Reduction : 0
NEMA ST-20 Audible Sound Level: 50
Efficiency : DOE 10 CFR Part 431 (2016)
UL Listed : Y
Enclosure Type: NEMA 2 (N3R w/opt'l weathershield)
Operating Frequency: 60 HZ

Catalog No V48M28T7516CU
Designation 87-TX-03

Qty List of Materials

- 1 3 Phase, 75 KVA, 480 Primary Volts, 208Y/120 Secondary Volts, 150C with 220C Insulation System Temperature Rise, Copper Winding Material, 60 HZ
- 1 Transformer Lug KIV1PH 50-75KVA or 3PH 75-112.5KV



Detail Bill of Material

Project Name: Pima County Tres Rios Gas Upgrading System
 Negotiation No: TU700805X9K3
 General Order No:
 Alternate No: 0003

Item No.	Qty	Product	Description
	3	HEAVY DUTY SAFETY SW	30A/3P FUSIBLE SWITCH 600V NEMA 7, 9, CROUSE-HINDS

Catalog No DS361FX
 Designation DS5, DS6, DS7

Qty List of Materials
 3 30A/3P FUSIBLE SWITCH 600V NEMA 7, 9, CROUSE-HINDS

Item No.	Qty	Product	Description
	3	HEAVY DUTY SAFETY SW	Safety Switch Access/Elec Interlock 30-800A 1NO-1N

Catalog No DS200EK1
 Designation DS5, DS6, DS7

Qty List of Materials
 3 Safety Switch Access/Elec Interlock 30-800A 1NO-1N

Item No.	Qty	Product	Description
	2	Safety Switches	Safety Switches

Catalog No DH361FWK316
 Designation 87-DS2,87-DS3

Qty List of Materials
 1 Auxiliary Contact Kit : 1NO/1NC - DS200EK1 (Field Installed)
 1 Ground Lug Kit : DS100GK (Field Installed)
 1 "R" Fuse Adapter Kit : DS16FK (Field Installed)
 1 Heavy Duty Switch - Fusible, 3-Pole, 600 VAC, 30 A, NEMA 4X (316 Stainless)

Item No.	Qty	Product	Description
	1	Safety Switches	Safety Switches

Catalog No DH321FWK316
 Designation 87-DS8

Qty List of Materials
 1 Auxiliary Contact Kit : 1NO/1NC - DS200EK1 (Field Installed)
 1 Ground Lug Kit : DS100GK (Field Installed)
 1 "R" Fuse Adapter Kit : DS12FK (Field Installed)
 1 Heavy Duty Switch - Fusible, 3-Pole, 600 VAC, 30 A, NEMA 4X (316 Stainless)

Item No.	Qty	Product	Description
	4	Safety Switches	Safety Switches

Catalog No DH321FGK
 Designation 87-DS9,87-DS10,87-DS11,87-DS12



Detail Bill of Material

Project Name: Pima County Tres Rios Gas
Upgrading System

Negotiation No: TU700805X9K3

General Order No:

Alternate No: 0003

Qty	List of Materials
1	Auxiliary Contact Kit : 1NO/1NC - DS200EK1 (Field Installed)
1	Ground Lug Kit : DS100GK (Field Installed)
1	"R" Fuse Adapter Kit : DS12FK (Field Installed)
1	Heavy Duty Switch - Fusible, 3-Pole, 240 VAC, 30 A, NEMA 1

Eaton Selling Policy 25-000 applies.

All orders must be released for manufacture within 90 days of date of order entry. If approval drawings are required, drawings must be returned approved for release within 60 days of mailing. If drawings are not returned accordingly, and/or if shipment is delayed for any reason, the price of the order will increase by 1.0% per month or fraction thereof for the time the shipment is delayed.

1 LOT FUSES FOR DISC'S LISTED

Detail Bill of Material

Project Name: TRES RIOS GMP 2
General Order No:

Negotiation No: F1680819X9K1
Alternate No: 0000

Item No.	Qty	Product	Description
	1	Safety Switches	Safety Switches

Catalog No DH322NRK

Qty List of Materials

1 Heavy Duty Switch - Fusible, 4-Wire, 240 VAC, 60 A, NEMA 3R

Item No.	Qty	Product	Description
	4	Safety Switches	Safety Switches

Catalog No DH221NRK

Qty List of Materials

1 Heavy Duty Switch - Fusible, 3-Wire, 240 VAC, 30 A, NEMA 3R

Item No.	Qty	Product	Description
	1	Safety Switches	Safety Switches

Catalog No DH361NWK

Qty List of Materials

1 Heavy Duty Switch - Fusible, 4-Wire, 600 VAC, 30 A, NEMA 4X (304 Stainless)

Item No.	Qty	Product	Description
	1	Safety Switches	Safety Switches

Catalog No DH222NWK

Qty List of Materials

1 Heavy Duty Switch - Fusible, 3-Wire, 240 VAC, 60 A, NEMA 4X (304 Stainless)

Item No.	Qty	Product	Description
	1	Safety Switches	Safety Switches

Catalog No DH221NWK

Qty List of Materials

1 Heavy Duty Switch - Fusible, 3-Wire, 240 VAC, 30 A, NEMA 4X (304 Stainless)

Item No.	Qty	Product	Description
	2	Safety Switches	Safety Switches

Catalog No DH364NWK

Qty List of Materials

1 "R" Fuse Adapter Kit : DS46FK (Field Installed)
1 Heavy Duty Switch - Fusible, 4-Wire, 600 VAC, 200 A, NEMA 4X (304)



Detail Bill of Material

Page 9

Project Name: TRES RIOS GMP 2
General Order No:

Negotiation No: F1680819X9K1
Alternate No: 0000

Stainless)

Item No.	Qty	Product	Description
	1	Safety Switches	Safety Switches

Catalog No DH365NWK

Qty List of Materials

- 1 "R" Fuse Adapter Kit : DS56FK (Field Installed)
- 1 Heavy Duty Switch - Fusible, 4-Wire, 600 VAC, 400 A, NEMA 4X (304 Stainless)

1 LOT FUSES FOR DISC'S LISTED



Verde Power Sales
 7777 E Paradise Lane
 Suite 106
 Scottsdale, AZ 85260
 (480) 991-9191

Quotation

Quote #: Q-06387-1
 Date: 06-AUG-2019
 Expires On: 05-SEP-2019

Sales Representative:
 Nicole Barrett
 nicole@verdepowersales.com

ARIZONA ELECTRIC SUPPLY - TUCSON 3310
 E GAS RD STE 100
 TUCSON AZ 85714

WE ARE PLEASED TO SUBMIT THE FOLLOWING QUOTATION SUBJECT TO THE TERMS AND CONDITIONS AS LISTED BELOW

QUOTE PREPARED BY	PHONE	EMAIL	DELIVERY METHOD	PAYMENT METHOD
Nicole Barrett	+1 (888) 762-1100	nicole@verdepowersales.com	Ship	Net 30 Days

LINE	QTY	CATALOG NUMBER	DESCRIPTION	UNIT PRICE	EXTENDED
01	2	65152R1-A2C3K8	MANUAL PME PAD-MOUNTED GEAR		
	2		65152R1--VOLTS: 14400 AMPERES: 600 --PAD-MOUNTED GEAR -- OUTDOOR PRIMARY DISTRIBUTION -- MANUAL MODEL PME-9		
	2		A2-LIGHT GRAY OUTDOOR FINISH		
	2		C3-KEY INTERLOCK		
	2		K8 - PME-6 -9 -12 - 15KV		
02	12	3093	SME-20 END FITTINGS		
03	12	FUSES	SMU-20 POWER FUSE UNIT (SIZE TBD AT THE TIME OF ORDER)		
				TOTAL:	

Ship Schedule

SHIP SCHEDULE TO BE CONFIRMED AT TIME OF ORDER PLACEMENT
 CURRENT ESTIMATE:
 TOTAL LEAD-TIME: 18-20 WEEKS



3760 E TENNESSEE ST
 TUCSON AZ 85714
 Phone: 520-838-5300
 Fax: 520-884-1115

To: ASHTON COMPANY, THE
 2727 S COUNTRY CLUB RD
 TUCSON AZ 85713-4046
 Attn: TRES RIOS GMP2
 Phone: 520-624-5500
 Fax: 520-791-9059
 Email:

Date: 11/01/2019
 Proj Name:
 GB Quote #: 0234022825
 Release Nbr:
 Purchase Order Nbr:
 Additional Ref#
 Valid From: 11/01/2019
 Valid To: 12/01/2019
 Contact: WILLIAM JENKINS
 Email: william.jenkins1@graybar.com

Proposal

We Appreciate Your Request and Take Pleasure in Responding As Follows

Item	Item/Type	Quantity	Supplier	Catalog Nbr	Description	Price	Unit	Ext.Price
100		1 EA			MISCELLANEOU LOT LIGHTING S SPECIA PER ATTACHED	\$12,815.00	1	\$12,815.00

Item Note: PRICE IS AS SPECIFIED WITH THE EXCEPTION OF THE 4- POLES. THE 4- POLES ARE QUOTED BY DESCRIPTION ONLY AND SUBJECT TO SUBMITTAL APPROVAL

- 4- POLES PER DETAIL
- 14- TYPE A
- 3- TYPE X
- 4- TYPE E
- 4- TYPE B
- 3- TYPE C

ALL FREIGHT INCLUDED IN PRICE QUOTED

Total in USD (Tax not included): \$12,815.00

This equipment and associated installation charges may be financed for a low monthly payment through Graybar Financial Services (subject to credit approval). For more information call 1-800-241-7408 to speak with a leasing specialist.

To learn more about Graybar, visit our website at www.graybar.com

24-Hour Emergency Phone#: 1-800-GRAYBAR

Subject to the standard terms and conditions set forth in this document. Unless otherwise noted, freight terms are F.O.B. shipping point prepaid and bill. Unless noted the estimated ship date will be determined at the time of order placement.



6829 W. Frye Rd.
 Chandler, AZ 85226
 P : 480-921-0498
 F : 480-921-7391
 E : sales@instandcontrols.com
 480-921-0498

Quote

22770
 Date 10/28/2019
 Quote Expires 11/28/2019

Bill To

The Ashton Company, Inc.
 2727 S. Country Club
 Tucson AZ 85713

Ship To

The Ashton Company, Inc.
 2727 S. Country Club
 Tucson AZ 85713

Contact Email

Patty Bitnar PBitnar@ashtoncoinc.com

Memo

Tucson Waste Water Facility - GMP2 Project - Rev.1 - Budgetary

Sales Rep Terms Entered By

Steven Taverna Net 30 Danny Arnold

Project

FOB Shipping Method Shipping Terms Collect Account Number

Shipping Point UPS Ground Pre-Pay and Add

No.	Manufacturer	Item	Description	Qty	Unit Price	Extended	Est. Lead Time
1	Endress + Hauser	PMP71-38E70/0	TAG: PIT-2000-02 Endress + Hauser Cerabar S PMP71 Model no.: PMP71-38E70/0 (PMP71-CBC1M61RAAAA+Z1) Pressure, piezoresistive. C - Approval: FM IS + XP Cl.I Div.1 Gr.A-D, zone 1,2 B - Output; Operating: 4-20mA HART; inside + LCD C - Housing; Cover Sealing; Cable Entry: T14 Alu IP66/67 NEMA6P; EPDM; NPT1/2 thread, T14 = side cover 1M - Sensor Range; Sensor Overload Limit: 4bar/400kPa/60psi gauge; 28bar/2800kPa/420psi 6 - Calibration; Unit: Sensor range; psi	1	1,400.37	1,400.37	ESTIMATED LEAD TIME 8 WORKING DAYS ARO + SHIPPING

6829 W. Frye Rd.
 Chandler, AZ 85226
 P : 480-921-0498
 F : 480-921-7391
 E : sales@instandcontrols.com
 480-921-0498

No.	Manufacturer	Item	Description	Qty	Unit Price	Extended	Est. Lead Time
2	Endress + Hauser	PMP71-3Q3W5/0	<p>1 - Membrane Material: 316L RA - Process Connection: Thread ANSI MNPT1/2 FNPT1/4, 316L A - Fill Fluid: Silicone oil A - Additional Option 1: Not selected A - Additional Option 2: Not selected Z1 - >>Marking: Tagging (TAG), see additional spec.</p> <p>TAGS: PIT-2020-01, PIT-2020-02, PIT-8730-01, PIT-8740-01 Endress + Hauser Cerabar S PMP71 Model no.: PMP71-3Q3W5/0 (PMP71-CBC1S61RAAAA+Z1)</p> <p>Pressure, piezoresistive.</p> <p>C - Approval: FM IS + XP Cl.I Div.1 Gr.A-D, zone 1,2 B - Output; Operating: 4-20mA HART; inside + LCD C - Housing; Cover Sealing; Cable Entry: T14 Alu IP66/67 NEMA6P; EPDM; NPT1/2 thread, T14 = side cover</p> <p>1S - Sensor Range; Sensor Overload Limit: 40bar/4MPa/600psi gauge; 160bar/16MPa/2400psi</p> <p>6 - Calibration; Unit: Sensor range; psi 1 - Membrane Material: 316L RA - Process Connection: Thread ANSI MNPT1/2 FNPT1/4, 316L A - Fill Fluid: Silicone oil A - Additional Option 1: Not selected A - Additional Option 2: Not selected Z1 - >>Marking: Tagging (TAG), see additional</p>	4	1,400.38	5,601.52	ESTIMATED LEAD TIME 8 WORKING DAYS ARO + SHIPPING

6829 W. Frye Rd.
 Chandler, AZ 85226
 P : 480-921-0498
 F : 480-921-7391
 E : sales@instandcontrols.com
 480-921-0498

No.	Manufacturer	Item	Description	Qty	Unit Price	Extended	Est. Lead Time
			spec.				
			** Notes **				
			This is a Budgetary Quotation				
			And is subject to change in part number and pricing based on final requirements and ranges requested.				
3	Endress + Hauser	PMC21-E4W4/0	TAG: PT8740-04 Endress + Hauser Cerabar PMC21 Model no.: PMC21-E4W4/0 (PMC21-FA1A1SBVXJA+Z1) Pressure, capacitive. FA - Approval: FM IS Cl. I, Div.1 Gr. A-D T4 1 - Output: 4-20mA A - Electrical Connection: Cable 5m, IP66/68 NEMA Type 4X/6P Encl. 1S - Sensor Range: 40bar/4MPa/600psi gauge, overload: 60bar/6MPa/900psi B - Calibration; Unit: Sensor range; mbar/bar VXJ - Process Connection: Thread ASME MNPT1/2 FNPT1/4, 316L A - Seal: FKM Z1 - >>Marking: Tagging (TAG), see additional spec.	1	528.00	528.00	ESTIMATED LEAD TIME 6 WORKING DAYS ARO + SHIPPING
4	Endress + Hauser	TH13-4A11A1DB OCAK	TAG: TT8740-04 Endress + Hauser RTD-Assembly TH13, TW-Type U.S.Style	1	1,055.78	1,055.78	ESTIMATED LEAD TIME 9 WORKING DAYS ARO +



Quote

Date 10/28/2019

6829 W. Frye Rd.
 Chandler, AZ 85226
 P : 480-921-0498
 F : 480-921-7391
 E : sales@instandcontrols.com
 480-921-0498

No.	Manufacturer	Item	Description	Qty	Unit Price	Extended	Est. Lead Time
			Model no.: TH13-4A11A1DBOCAK Temperature measuring device with thermowell. Spring loaded element. Pt100 Sensor comply with IEC60751 standard, alpha=0.00385. 4 - Thermowell Immersion length U: 10.50 inch 10.5 inch A1 - Process Connection: NPT1/2 male thread, 316 1 - Thermowell Shape: Straight A - Thermowell Lag T: Not selected 1 - Extension: Hex nipple 316 E=1" D - Sensor Type: 1 Pt100 class A, 3 wire, -200-600oC B - Enclosure; Cable Entry: Alu, E+H blue; NPT1/2 O - Electrical Connection: HART TMT182, FM/CSA IS, adv. diagnostics C - Additional Option 1: Non-SIL A - Additional Option 2: Not selected K - Version: Standard A - >>>Marking: Tagging (TAG), metal Details: Low range value: 328 °F Upper range value: 1112 °F Failure mode(1=low<3.6mA,2=high>21mA): 2 Bustag: 71072708 Metal label				SHIPPING

	Subtotal	8,585.67
Shipping Cost (UPS Ground)		0.00
Tax (AZ_AZ 7.8%)		669.68
	Total	\$9,255.35

Should you have any questions concerning any of the details of the document, feel free to contact Instrumentation And Controls.
 *All sales order related transactions with Instrumentation and Controls, LLC shall be governed by Instrumentation and Controls, LLC's Standard Sales Terms and Conditions (IAC Terms) which are subject to modification. Please visit <http://instandcontrols.com/terms> for the most up to date IAC Terms. Any contracts or agreements which are currently in place shall apply and will not be replaced by the IAC Terms.

Industrial Specialties Supply, Inc

3941 E 29th St Suite 606
Tucson, AZ 85711

QUOTATION

Quote Number: Q019322
Quote Date: Oct 25, 2019
Page: 1

Voice: 520-745-5800
Fax: 520-745-5801

Quoted To:
THE ASHTON COMPANY
PO BOX 26927
TUCSON, AZ 85726-6927
USA

Customer ID	Good Thru	Payment Terms	Sales Rep
ASHCOM	11/24/19	1% 10, Net 30 Days	

Quantity	Item	Description	Unit Price	Amount
2.00		TRES RIOS-GMP2 PROJECT ASHCROFT PRESSURE GAUGE 100-T5500SL-04LGR, 0/100 PSI, STAINLESS STEEL CASE AND BOURDON TUBE, GLYCERINE FILLED DELIVERY: 4 TO 6 WEEKS ARO + FRT. UPS	174.00	348.00
1.00		ASHCROFT BIMETALIC THERMOMETER 50EI60E025XCS50/300F, 5" DIAL, 2.5" STEM, 1/2" NPT CONNECTION DELIVERY: 3 WEEKS ARO + FRT UPS LET US KNOW IF YOU NEED THE THERMOWELL FOR IT ?	138.00	138.00
			Subtotal	486.00
			Sales Tax	
			Freight	
			TOTAL	486.00



10/28/2019

Bill To:
 Patty Bitnar
 THE ASHTON COMPANY
 PO BOX 26927
 2727 S Country Club Rd
 TUCSON, AZ 85726 USA
 520-505-3561
 pbitnar@ashtoncoinc.com
 Patty Britnar

Please address order to:
Fluid Components International LLC
 c/o
 Phoenix Instrumentation
 Suite 101-PMB 401
 15508 W. Bell Rd.
 Surprise, AZ 85374-2432 USA

Ship To:
 THE ASHTON COMPANY
 PO BOX 26927
 2727 S Country Club Rd
 TUCSON, AZ 85726 USA

Shipment Terms: Prepaid & Add
 Ship Via: BEST PRACTICAL
 Payment Terms: NET 30 O.A.C.
 Lead Time: 4 weeks (Upon Acceptance of Order)
 Valid For: 30 Days

Line Item	Qty	Description	Unit Price (US\$)	Extended Price (US\$)
1	1	ST80L-43JL000F10FAFE001 AVAL: SQER000522_1_1_1-5		
		Block Code Name Option		
		1 4 Flow Element		
			F Style, 316L Stainless Steel, 250°F [121°C]	
		2 3 In-Line Body Material of Construction		
			316L Stainless Steel; all welded connection of sensor element	
		3 J In-Line Body Type / Diameter / Length		
			2 Inch Pipe, Schedule 40, 18 inch [457 mm]	
		4 L In-Line Body Type / Diameter		
			L: Flange; 316L SST ANSI 2 In. 300 lb.	
		567 000 Insertion U-Length		
			Code is Always 0	
		8 F Pipe Mounting and Flow Direction		
			Horizontal Pipe; Top Mount (Reference Diagram for Flow and Integral Display/Blind Direction)	
		9 1 Transmitter Enclosure		
			Integral Mount, Aluminum; with NPT Cable Entries	
		10 0 Interconnecting Cable Length		
			Not Required (Specify with Integral Configurations or if Supplying Own Cable)	
		11 F Transmitter Power Supply and Display		
			24 Vdc Power; with Digital Display; 4-Button Keypad	
		12 A Transmitter Outputs and Communications		
			(2) 4-20 mA Analog; HART, Modbus	
		13 F Calibration Application		
			Hydrocarbon [methane, ethane, propane]	
		14 E Calibration, Set-Up and Conditions		
			Extended Temp Comp and Extended Range	
		15 0 Second Calibration Application		
			Not Required	
		16 0 Second Calibration, Set-Up and Conditions		
			Not Required	
		17 1 Agency Approval		
			FM	
		Customer Tag Lines: FIT-8740-01		
			\$5,667.00	\$5,667.00

Line Item	Qty	Description	Unit Price (US\$)	Extended Price (US\$)
2	1	ST80-10C0060F10FAFE001 Insertion Air & Gas Mass Flow Meter AVAL: SQER000522_1_2_1-3		
		Block Code Name Option		
		1 1 Flow Element	350°F [177°C] -FPC Style; 316L Stainless Steel	
		2 0 Pressure Measurement	Always '0' for this Configuration	
		3 C Process Connection	Compression Fitting, Teflon Ferrule : 3/4 Inch	
		4 0 Flange Required	Male NPT	
		567 060 Insertion U-Length	1-6 inches [152,4 mm]	
		8 F Pipe Mounting and Flow Direction	Horizontal Pipe; Top Mount, Display/Blind Front Facing Forward (Reference Diagram for Flow Direction)	
		9 1 Transmitter Enclosure	Integral Mount, Aluminum; with NPT Cable Entries	
		10 0 Interconnecting Cable Length	Not Required (Specify with Integral Configurations or if Supplying Own Cable)	
		11 F Transmitter Power Supply and Display	24 Vdc Power; with Digital Display; 4- Button Keypad	
		12 A Transmitter Outputs and Communications	(2) 4-20 mA Analog; HART, Modbus	
		13 F Calibration Application	Custom Calibration : Hydrocarbons (Methane, Ethane, Propane, etc.)	
		14 E Calibration, Set-Up and Conditions	Extended Temp Comp and Extended Range	
		15 0 Second Calibration Application	Not Required	
		16 0 Second Calibration, Set-Up and Conditions	Not Required	
		17 1 Agency Approval	FM	
		Customer Tag Lines: FIT-2020-01	\$4,577.00	\$4,577.00

Total Quotation Price:

\$10,244.00

Jasen Garcia
Phoenix Instrumentation
jaseng@iwestco.com
602-393-3045
602-393-3046

This proposal, including any attachments, may contain confidential data and information that is the property of Fluid Components International LLC (FCI). Disclosure of this data to you is expressly conditional upon your assent that its use is within your company only and does not include manufacture or processing uses. Any other use is strictly prohibited without prior written consent of FCI.

© 2016 Fluid Components LLC. All Rights Reserved | Privacy Policy: <https://www.fluidcomponents.com/privacy-policy>

Date: 10/28/2019					
Phoenix Instrumentation 602 393-3045					
Line Number: 1					
AVAL Record Number: SQER000522_1_1_1-5					
Line Item: ST80L-43JL000F10FAFE001					
Prepared by: Jasen Garcia jaseng@iwestco.com					
Customer Tag Lines: FIT-8740-01					
Application Parameters:					
Media:	Flare Gas: Carbon Dioxide 35%, Methane 55%, Nitrogen 10%				
Line Size(I.D.):	1.939 Inches (2 inch sch. 80 (1.939 inch (49.25 mm) I.D.)) Spool				
	Minimum	Normal	Maximum	Design Max	Units
Flow Range	5	473	738	738	SCFM
Process Temperature	80	100	110	110	deg F
Process Pressure	90	225	225	225	psig
Actual Velocity	0.2530 to 37.34 ft/sec @ 225 psig and 100 deg F				
Standard Velocity	4.064 to 599.8 SFPS @ 14.70 psia and 70 deg F				
Reynolds Number	4815.6 to 710940				
Standard Conditions	14.70 psia and 70 deg F				
Calibration Options	Standard Profile/ Extended Range				
Selected Instrument:					
Model:	ST80L				
Base Accuracy:	1.00% rdg. + 0.50% of full scale.				
Repeatability:	0.50% rdg.				
Totalizer:	Initialized				
Factory Set-Up Details:					
Output 1 (HART):	0 to 738 SCFM				
Output 2 (HART):	0 to 120 deg F				
Output 3:	Not Available on Model ST80L				
Pulse/Frequency Output:	Not Available on Model ST80L				
Bus Protocol:	HART/Modbus				
Thermo-Physical Properties of the Selected Media:					
Molecular Weight	27.029	Specific Gravity	0.9331		
Compressibility Factor	0.9576	Prandtl Number	0.6881		
	Imperial Measurements		Metric Measurements		
Density	1.1265 Lbm/Ft ³		18.045 Kg/m ³		
Specific Heat	0.31115 BTU/Lbm-Deg R		1.30272 KJ/Kg-K		
Thermal Conductivity	0.015561 BTU/Hr-Ft-Deg R		0.026932 W/m-K		
Absolute Viscosity	9.5599E-06 Lbm/Ft-Sec		142.3 Micropoise		
Standard Density	0.070124 Lbm/Ft ³		1.1233 Kg/m ³		

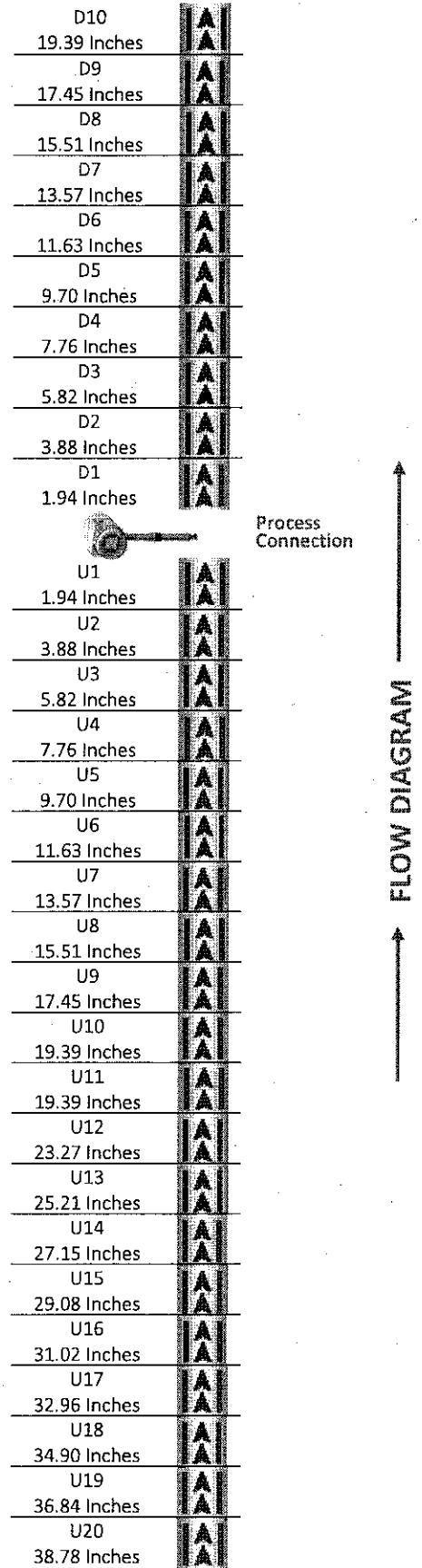



Application Evaluation

Date	28-Oct-2019	Representative	Joe Garcia
Customer	THE ASHTON COMPANY	Firm	1284
Contact	Bitnar, Patty	Phone	
City	TUCSON	email	

Application Parameters

Media: Flare Gas - 3 components. Mole (Volume) percentage.

Carbon Dioxide	35.000%
Methane	55.000%
Nitrogen	10.000%

Line Description 2 inch sch. 80 (1.939 inch (49.25 mm) I.D.) spool section.



X = Install location

	<u>Min</u>	<u>Normal</u>	<u>Max</u>	<u>Units</u>
Flow	5	473	738	SCFM
Temperature	80	100	110	deg F
Pressure	90	225	225	psig
Standard Conditions	14.70 psia and 70 deg F			
Calibration Options	Extended Range			
Analog Output 1	4-20 mA = 0 to 738 SCFM (Set for Flow)			
Analog Output 2	4-20 mA = 0 to 120 deg F (Set for Temperature)			

Recommended Model	ST80L
Base Accuracy	1.00% rdg. + 0.50% of full scale.
Accuracy issues	none
Repeatability	0.50% rdg.
Sensor Head	Standard Sensor Head • Temperature Compensation Required
Cal Code	Universal Calibration Code: F • Cal. Setup Code: E
Flow Direction	To Be Determined



Application Evaluation

Thermo-Physical Properties of "Flare Gas" @ 225 psig and 100 deg F

Molecular Weight	27.029	
Specific Gravity	0.9331	
Compressibility Factor	0.9576	
Density	1.1265 Lbm/Ft ³	Metric Equivalent 18.045 Kg/m ³
Specific Heat	0.31115 BTU/Lbm-Deg R	1.30272 KJ/Kg-K
Thermal Conductivity	0.015561 BTU/Hr-Ft-Deg R	0.026932 W/m-K
Absolute Viscosity	9.5599E-06 Lbm/Ft-Sec	142.3 Micropoise
Prandtl Number	0.6881	
Standard Density	0.070124 Lbm/Ft ³	1.1233 Kg/m ³

Application Range

Actual Velocity	0.2530 to 37.34 ft/sec @ 225 psig and 100 deg F
Standard Velocity	4.064 to 599.8 std. ft/sec at 70 deg. F and 14.7 psia
Reynolds Number	4816.6 to 710940

Accuracy/Repeatability Issues:

- No accuracy or repeatability issues:



Application Evaluation

Date 28-Oct-2019
Customer THE ASHTON COMPANY
Contact Bitnar, Patty
City TUCSON

Representative Joe Garcia
Firm 1284
Phone
email

ST80L Flow Rate vs. Pressure Drop Estimate
Pressure loss coef. estimate (Cp)=0.00
Pressure drop=Cp*1/2*density*velocity^2
Generated by AVAL on 28-Oct-2019

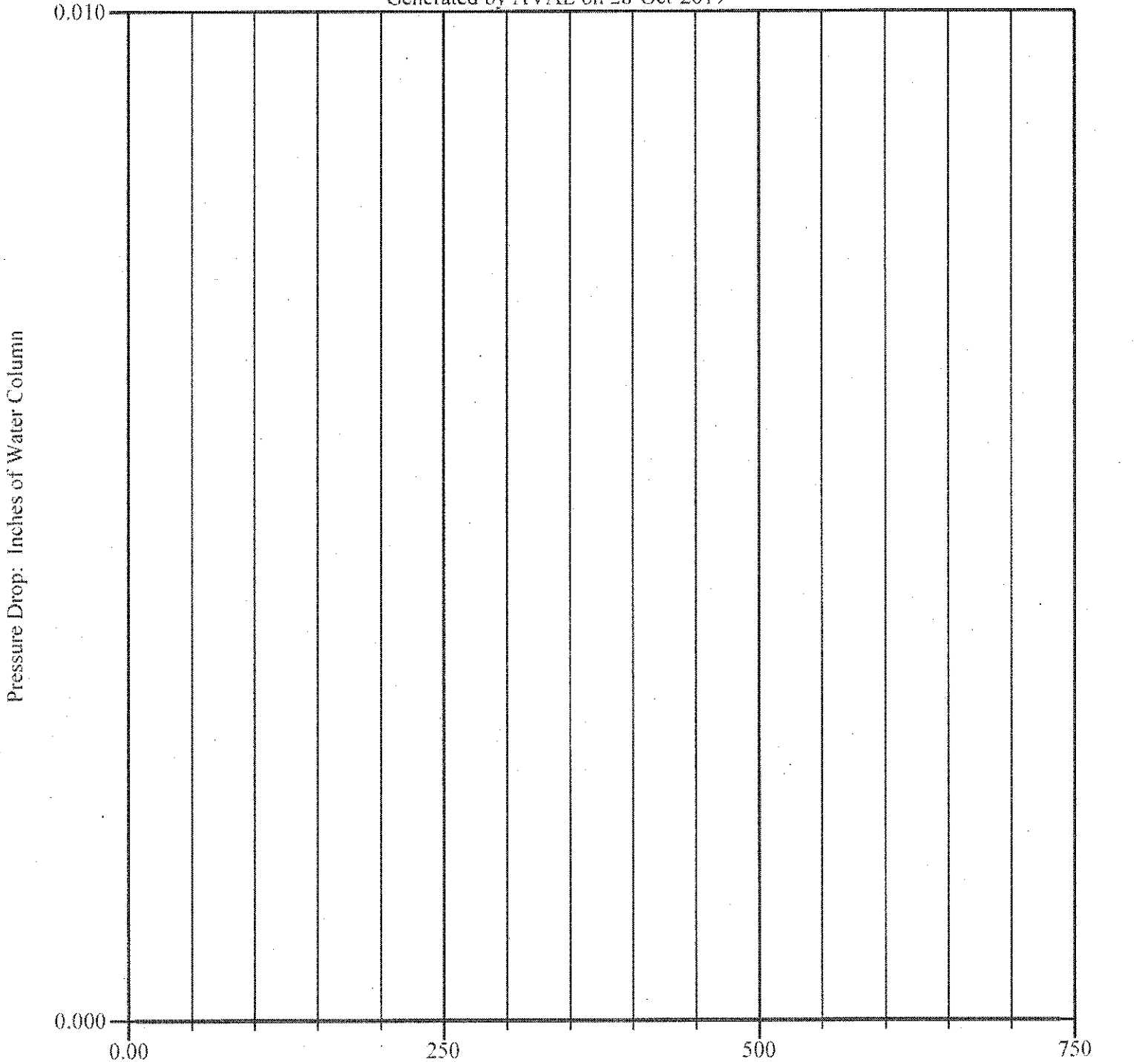

Flowrate: SCFM of Flare Gas @ 225 psig and 100 deg F (2 inch sch. 80 (1.939 inch (49.25 mm) I.D.) spool section.)

Date: 10/28/2019

Phoenix Instrumentation 602 393-3045

Line Number: 1

Line Item: ST80L-43JL000F10FAFE001

Prepared by: Jasen Garcia jaseng@iwestco.com

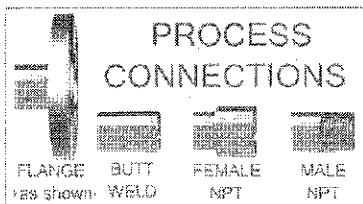
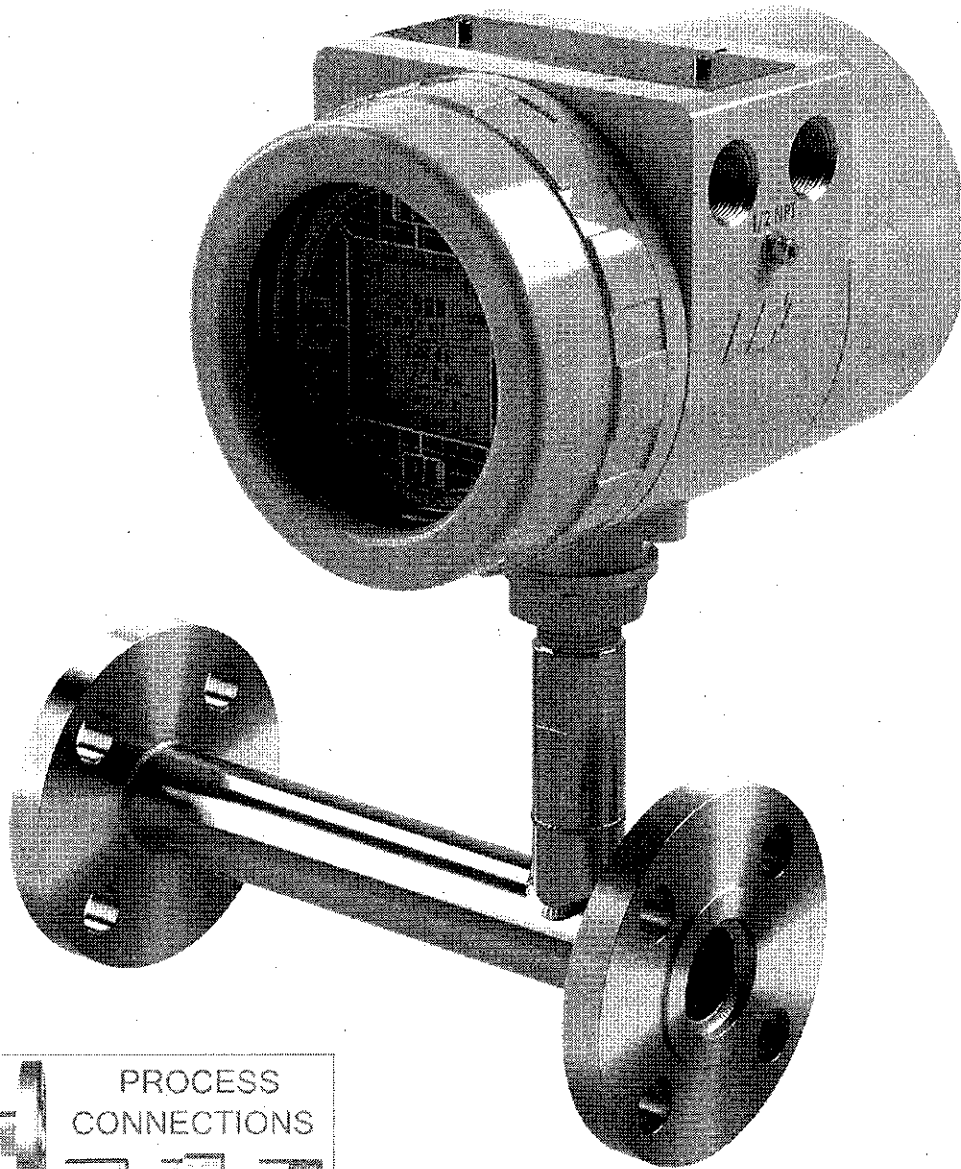

Disclaimer: This drawing is for reference only and subject to change without notification. Actual, project-specific drawings for your application are available by contacting Fluid Components International (FCI).

TABLE 1		4-20mA / HART OUTPUT WIRING CONNECTIONS							
PIN NO.	PIN LABEL	ANALOG OUTPUT 4-20mA				HART OUTPUT			
		CH1		CH2		CH1 (INTERNAL)		CH1 (EXTERNAL)	
1	4-20mA INT HART (+)	+	*	*	*	+	*	*	*
2	4-20mA RTN INT HART RTN EXT HART (+)	*	-	*	*	*	-	+	*
3	4-20mA	*	*	+	*	*	*	*	*
4	4-20mA RTN	*	*	*	-	*	*	*	*
5	EXT HART RTN	*	*	*	*	*	*	*	-
6	RETURN	*	*	*	*	*	*	*	*

J25 CONNECTOR 16-28 AWG (MAIN BOARD)

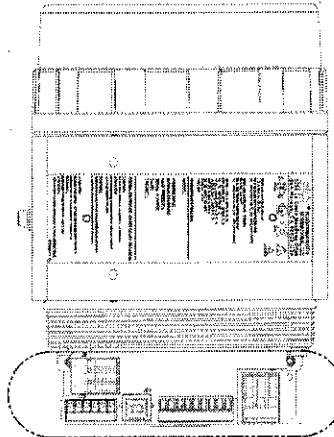

TABLE 2		
PIN NO.	MODBUS	FOUNDATION FIELDBUS / PROFIBUS
	PIN LABEL	
1	B (+)	FIELDBUS_A
2	RETURN	RETURN
3	A (-)	FIELDBUS_B

J8 CONNECTOR 12-24 AWG (MAIN BOARD)

TABLE 3		
PIN NO.	(AC POWER 85-265 Vac)	(DC POWER 19.2-28.8 Vdc)
1	AC LINE	DC +
2	AC NEUT	DC -
3	E.GRND	E.GRND

P1 CONNECTOR 12-24 AWG (P.S BOARD)

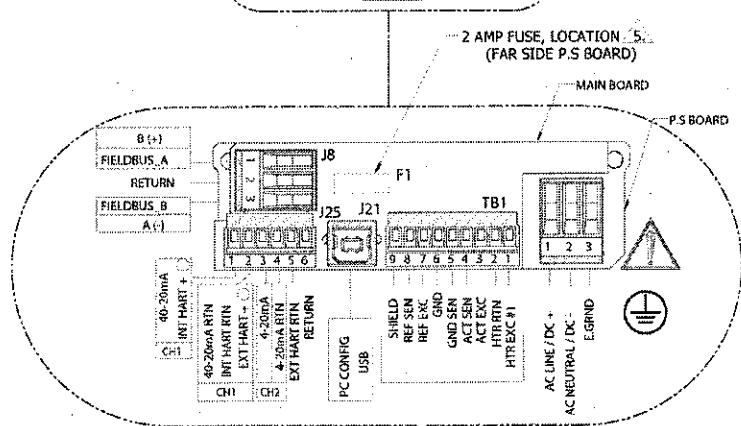
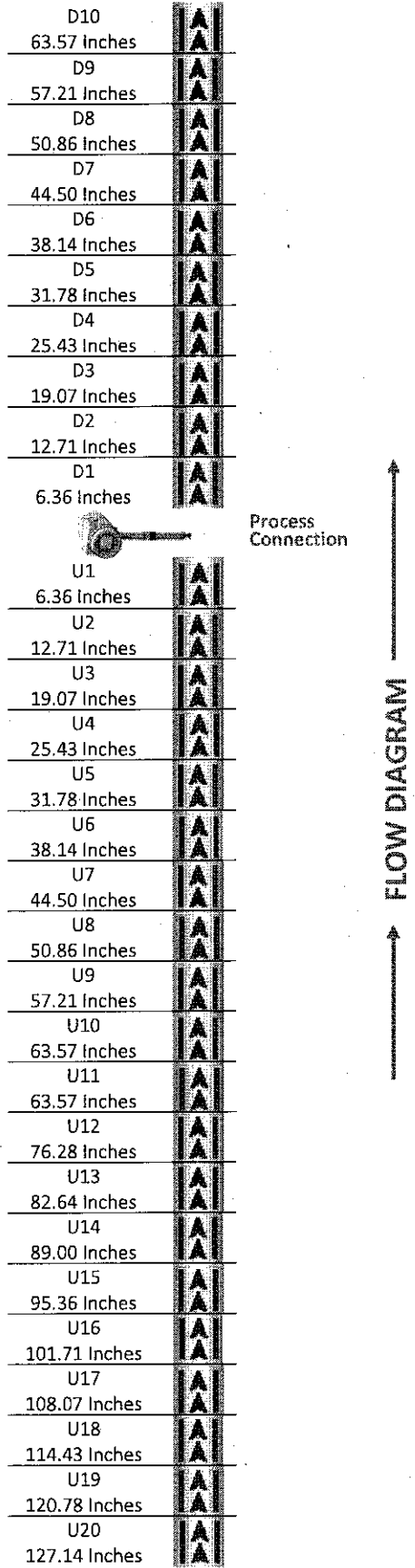

TABLE 4						
CONNECTION	10 FT	50 FT	100 FT	250 FT	500 FT	1000 FT
POWER AC OR DC	22	22	22	20	18	16
ANALOG OUT (HART)	16-28	16-28	16-28	16-28	16-28	16-28
DIGITAL OUT (FOUNDATION FIELDBUS)	FF-844-H1 (14-24 AWG)					
MODBUS	RS485 (14-24 AWG)					

INSTRUMENT WIRING RECOMMENDED AWG

Disclaimer: This drawing is for reference only and subject to change without notification. Actual, project-specific drawings for your application are available by contacting Fluid Components International (FCI).

Date: 10/28/2019					
Phoenix Instrumentation 602 393-3045					
Line Number: 2					
AVAL Record Number: SQER000522_1_2_1-3					
Line Item: ST80-10C0060F10FAFE001					
Prepared by: Jasen Garcia jaseng@lwestco.com					
Customer Tag Lines: FIT-2020-01					
Application Parameters:					
Media:	Flare Gas: Carbon Dioxide 35%, Methane 55%, Nitrogen 10%				
Line Size(I.D.):	6.357 Inches (6 inch Sch 105) Round				
	Minimum	Normal	Maximum	Design Max	Units
Flow Range	9	833	1800	1800	SCFM
Process Temperature	80	100	110	110	deg F
Process Pressure	11	11	11	11	in H2O(g)
Actual Velocity	0.7005 to 140.1 ft/sec @ 11 in H2O(g) and 100 deg F				
Standard Velocity	0.6805 to 136.1 SFP5 @ 14.70 psia and 70 deg F				
Reynolds Number	2644.5 to 528900				
Standard Conditions	14.70 psia and 70 deg F				
Calibration Options	Standard Profile/ Extended Range				
Selected Instrument:					
Model:	ST80				
Base Accuracy:	1.00% rdg. + 0.50% of full scale.				
Repeatability:	0.50% rdg.				
Totalizer:	Initialized				
Factory Set-Up Details:					
Output 1 (HART):	0 to 1800 SCFM				
Output 2 (HART):	0 to 120 deg F				
Output 3:	Not Available on Model ST80				
Pulse/Frequency Output:	Not Available on Model ST80				
Bus Protocol:	HART/Modbus				
Thermo-Physical Properties of the Selected Media:					
Molecular Weight	27.029	Specific Gravity	0.9331		
Compressibility Factor	0.9973	Prandtl Number	0.7033		
	Imperial Measurements		Metric Measurements		
Density	0.068127 Lbm/Ft ³		1.0913 Kg/m ³		
Specific Heat	0.31801 BTU/Lbm-Deg R		1.33143 KJ/Kg-K		
Thermal Conductivity	0.015561 BTU/Hr-Ft-Deg R		0.026932 W/m-K		
Absolute Viscosity	9.5599E-06 Lbm/Ft-Sec		142.3 Micropoise		
Standard Density	0.070124 Lbm/Ft ³		1.1233 Kg/m ³		





Application Evaluation

Date	28-Oct-2019	Representative	Joe Garcia
Customer	THE ASHTON COMPANY	Firm	1284
Contact	Bitnar, Patty	Phone	
City	TUCSON	email	

Application Parameters

Media: Flare Gas - 3 components. Mole (Volume) percentage.

Carbon Dioxide	35.000%
Methane	55.000%
Nitrogen	10.000%

Line Description 6.357 Inches I.D. pipe. (6 inch Sch 10S).



X = Install location

	<u>Min</u>	<u>Normal</u>	<u>Max</u>	<u>Units</u>
Flow	9	833	1800	SCFM
Temperature	80	100	110	deg F
Pressure	11	11	11	in H2O(g)
Standard Conditions	14.70 psia and 70 deg F			
Calibration Options	Extended Range			
Analog Output 1	4-20 mA = 0 to 1800 SCFM (Set for Flow)			
Analog Output 2	4-20 mA = 0 to 120 deg F (Set for Temperature)			

Recommended Model	ST80
Base Accuracy	1.00% rdg. + 0.50% of full scale.
Accuracy issues	none
Repeatability	0.50% rdg.
Sensor Head	Standard Sensor Head • Temperature Compensation Required
Cal Code	Universal Calibration Code: F • Cal. Setup Code: E
Flow Direction	To Be Determined



Application Evaluation

Thermo-Physical Properties of "Flare Gas" @ 11 in H2O(g) and 100 deg F

Molecular Weight	27.029	
Specific Gravity	0.9331	
Compressibility Factor	0.9973	
Density	0.068127 Lbm/Ft ³	Metric Equivalent 1.0913 Kg/m ³
Specific Heat	0.31801 BTU/Lbm-Deg R	1.33143 KJ/Kg-K
Thermal Conductivity	0.015561 BTU/Hr-Ft-Deg R	0.026932 W/m-K
Absolute Viscosity	9.5599E-06 Lbm/Ft-Sec	142.3 Micropoise
Prandtl Number	0.7033	
Standard Density	0.070124 Lbm/Ft ³	1.1233 Kg/m ³

Application Range

Actual Velocity	0.7005 to 140.1 ft/sec @ 11 in H2O(g) and 100 deg F
Standard Velocity	0.6805 to 136.1 std. ft/sec at 70 deg. F and 14.7 psia
Reynolds Number	2644.5 to 528900

Accuracy/Repeatability Issues:

- No accuracy or repeatability issues:



Application Evaluation

Date 28-Oct-2019
 Customer THE ASHTON COMPANY
 Contact Bitnar, Patty
 City TUCSON

Representative Joe Garcia
 Firm 1284
 Phone
 email

ST80 Flow Rate vs. Pressure Drop Estimate
 Pressure loss coef. estimate (Cp)=0.40
 $Pressure\ drop = Cp * 1/2 * density * velocity^2$
 Generated by AVAL on 28-Oct-2019

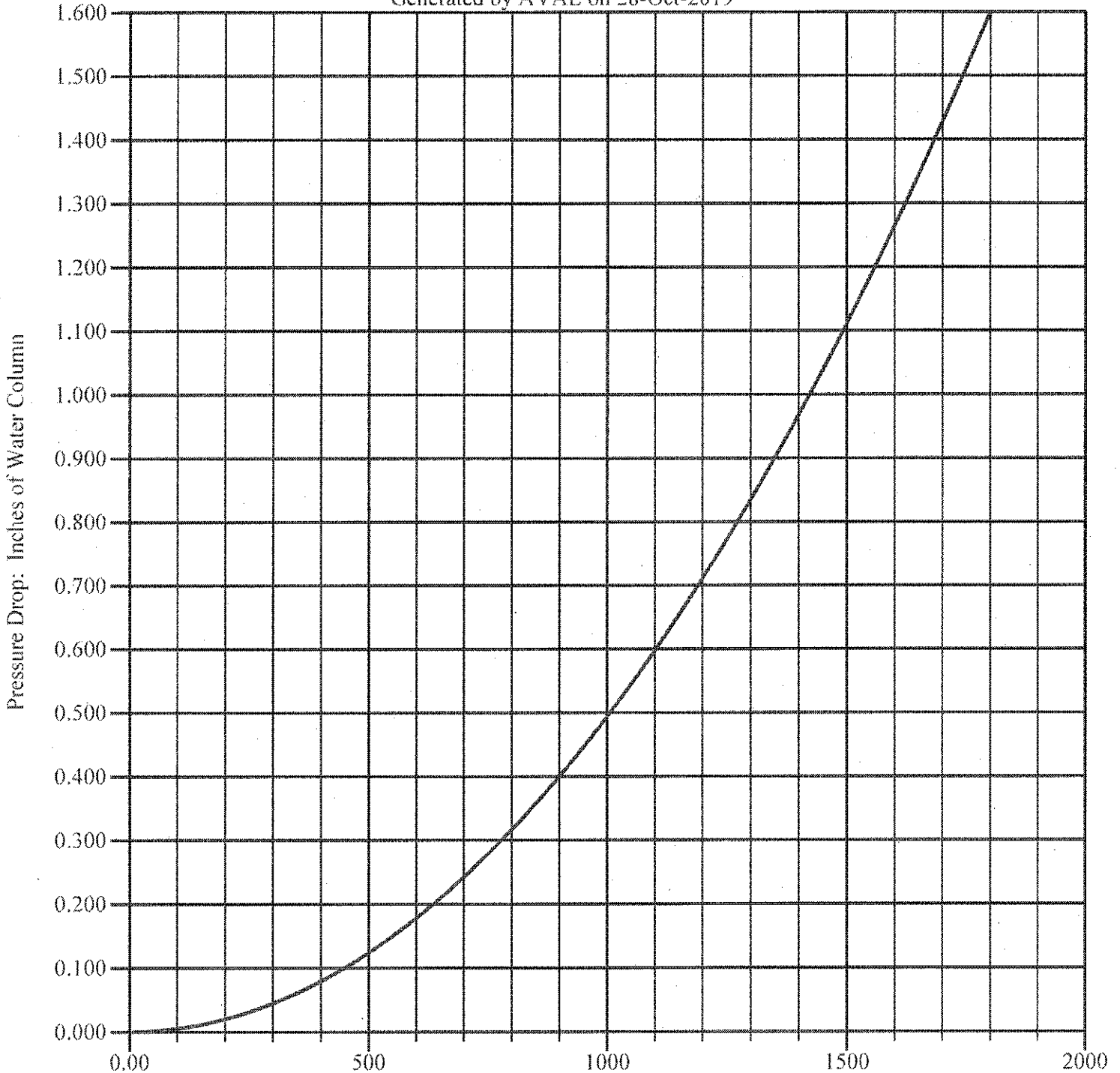

Flowrate: SCFM of Flare Gas @ 11 in H2O(g) and 100 deg F (6.357 Inches I.D. pipe. (6 inch Sch 10S).)

Date: 10/28/2019

Phoenix Instrumentation 602 393-3045

Line Number: 2

Line Item: ST80-10C0060F10FAFE001

Prepared by: Jasen Garcia jaseng@lwestco.com

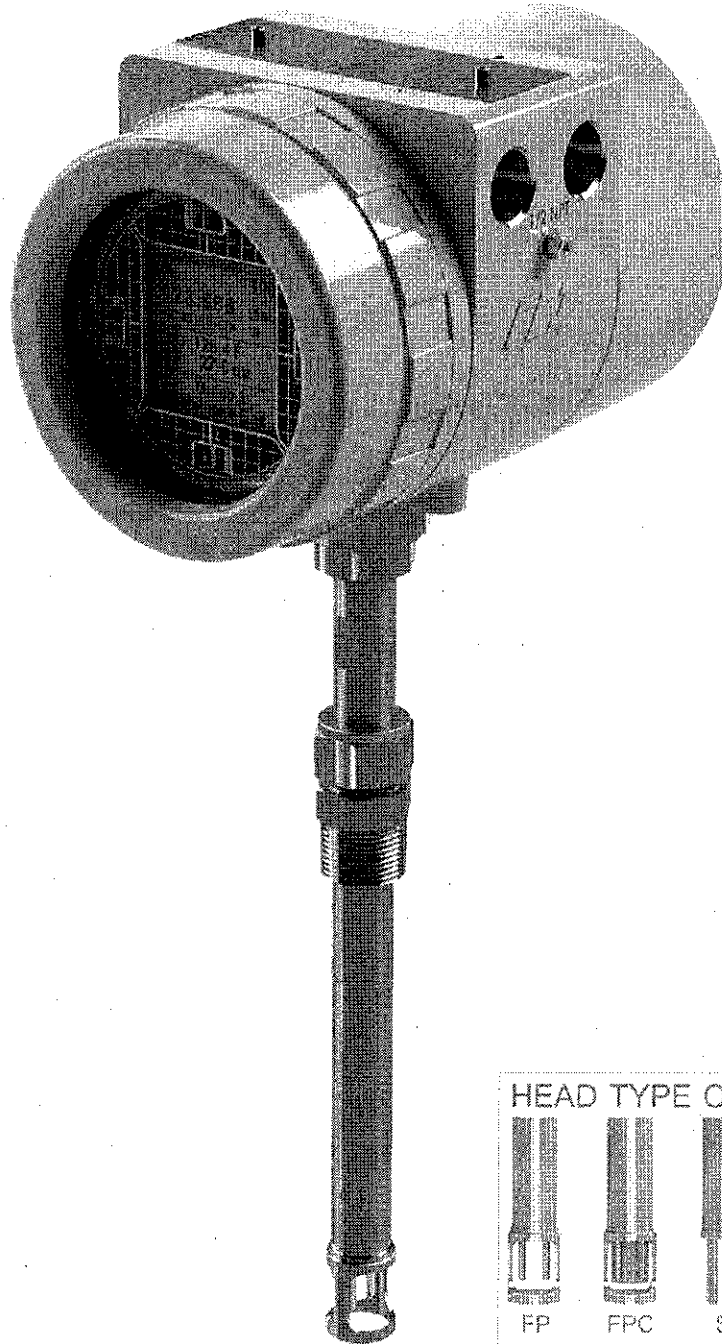

Disclaimer: This drawing is for reference only and subject to change without notification. Actual, project-specific drawings for your application are available by contacting Fluid Components International (FCI).

TABLE 1		4-20mA / HART OUTPUT WIRING CONNECTIONS							
PIN NO.	PIN LABEL	ANALOG OUTPUT 4-20mA				HART OUTPUT			
		CH1		CH2		CH1 (INTERNAL)		CH1 (EXTERNAL)	
1	4-20mA INT HART (+)	+	*	*	*	+	*	*	*
2	4-20mA RTN INT HART RTN EXT HART (+)	*	-	*	*	*	-	+	*
3	4-20mA	*	*	+	*	*	*	*	*
4		4-20mA RTN	*	*	*	-	*	*	*
5	EXT HART RTN	*	*	*	*	*	*	*	-
6	RETURN	*	*	*	*	*	*	*	*

J25 CONNECTOR 16-28 AWG (MAIN BOARD)

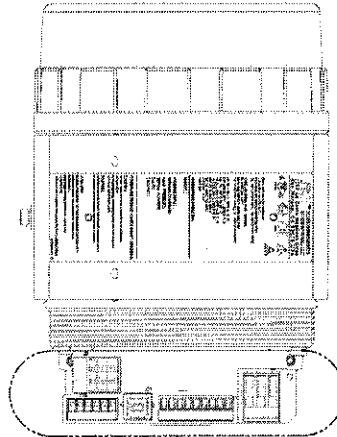

TABLE 2		
PIN NO.	MODBUS	FOUNDATION FIELDBUS / PROFIBUS
	PIN LABEL	
1	B (+)	FIELDBUS_A
2	RETURN	RETURN
3	A (-)	FIELDBUS_B

J8 CONNECTOR 12-24 AWG (MAIN BOARD)

TABLE 3		
PIN NO.	(AC POWER 85-265 Vac)	(DC POWER 19.2-28.8 Vdc)
1	AC LINE	DC +
2	AC NEUT	DC -
3	E.GRND	E.GRND

P1 CONNECTOR 12-24 AWG (P.S BOARD)

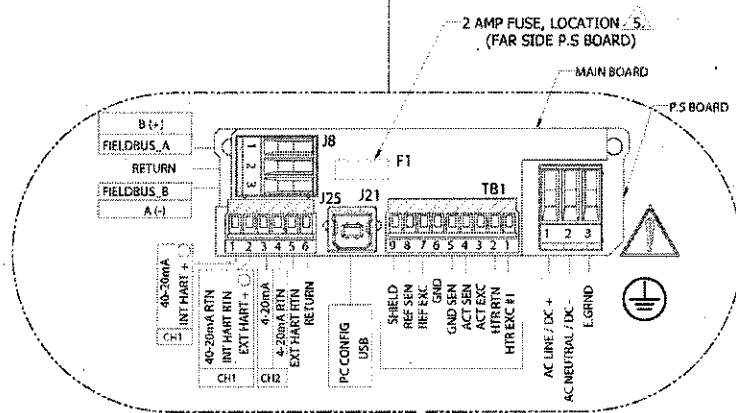

TABLE 4						
CONNECTION	10 FT	50 FT	100 FT	250 FT	500 FT	1000 FT
POWER AC OR DC	22	22	22	20	18	16
ANALOG OUT (HART)	16-28	16-28	16-28	16-28	16-28	16-28
DIGITAL OUT (FOUNDATION FIELDBUS)	FF-844-H1 (14-24 AWG)					
MODBUS	RS485 (14-24 AWG)					

INSTRUMENT WIRING RECOMMENDED AWG

Disclaimer: This drawing is for reference only and subject to change without notification. Actual, project-specific drawings for your application are available by contacting Fluid Components International (FCI).



Application Evaluation

Date 28-Oct-2019
Customer THE ASHTON COMPANY
Contact Bitnar, Patty
City TUCSON

Representative Joe Garcia
Firm 1284
Phone
email

Model: ST80 Flow Direction: Left to Right (back of page to front of page)
Process Connection: Thredolet, 3/4 inch 3000#. Face Height = 1.06 inches (27.0 mm)
Line Size: 6 inch Sch 10S, inside diameter 6.357 inches (161.5 mm)
Configuration selections: Block 1: 1, Block 3: C, Block 4: 0

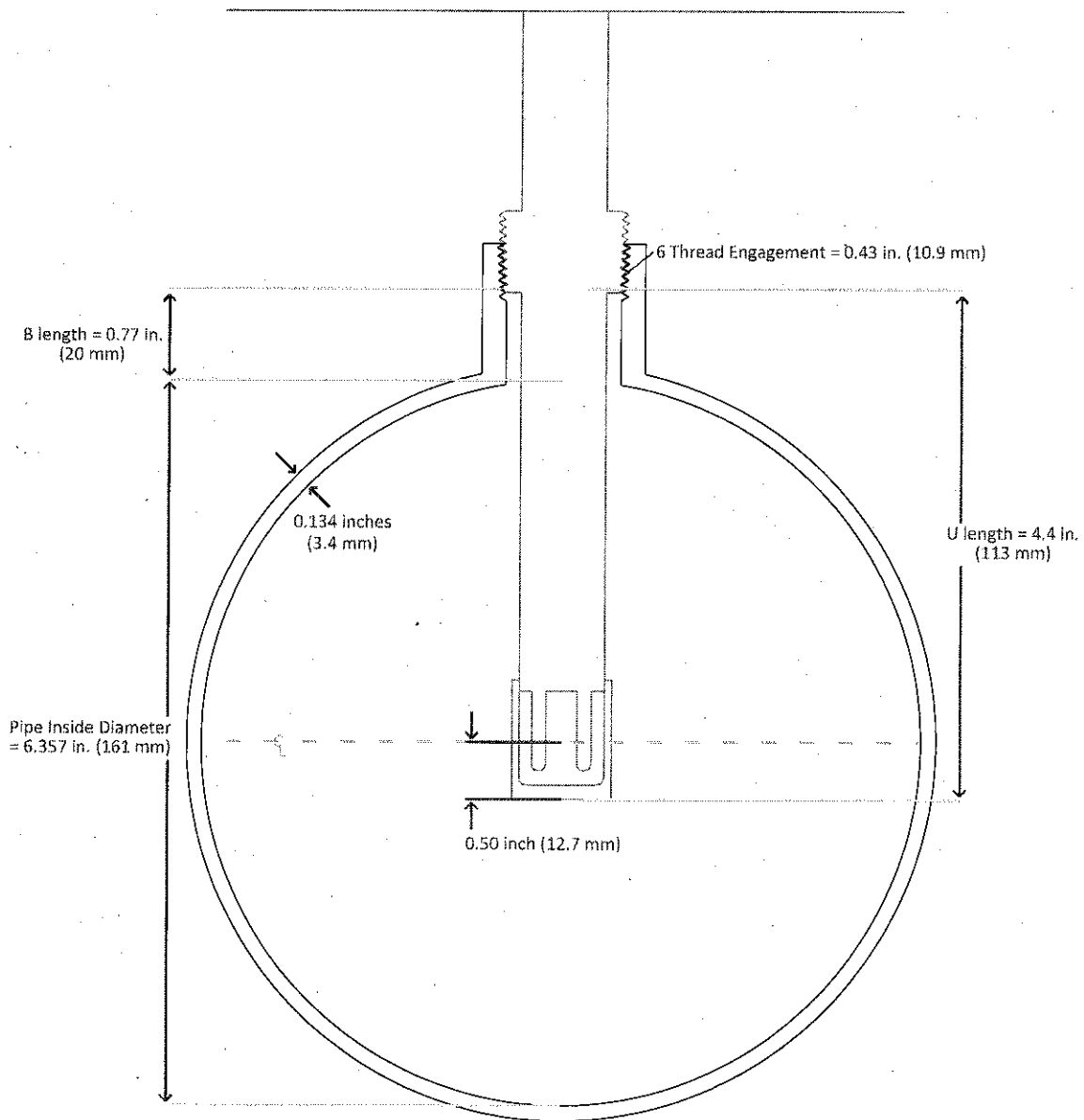

TERMS AND CONDITIONS

1. **HOME OFFICE APPROVAL**
Any order issued by Buyer pursuant to this offer by Seller shall not be binding on Seller until received and approved in writing at Seller's home office, including Seller's approval of Buyer's credit.
2. **PRICE**
The price to be paid by Buyer shall be that contained on the face hereof, providing however, the Seller accepts that orders calling for future delivery shall be subject to the prices in effect at the time of order. Written quotations are valid for the calendar length indicated on the face of the quote from the date issued and are subject to termination by Seller upon notice, with or without cause, during that period. Seller reserves the right to apply a minimum charge per order. Where delivery of goods is extended over a period of time, Seller may request progress payments concurrent with the amount of goods delivered or work performed.
3. **EXPEDITING CHARGES**
Should expediting charges be included as part of the order's pricing, whether a portion of the per unit cost or separate, the minimum expediting charge shall be determined on a prorata basis providing the order is shipped within the expediting period. The prorata amount of expediting charges shall be the original expediting charge multiplied by the ratio of the regular business days between the actual shipping date and the normal delivery date divided by the amount of regular business days between the expedited delivery date and the normal delivery date. Expediting charges shall be due in accordance with the agreed upon invoice terms.
4. **MODIFICATIONS**
A writing signed by an officer of Seller can only modify this Agreement.
5. **PAYMENT OF PURCHASE PRICE**
Except as otherwise provided, the purchase price for the goods must be paid by Buyer to Seller to the account designated on the face of this document, by check within thirty (30) days after the date of the invoice for the goods. If payment is not timely made, a monthly credit charge equal to one and one-half percent (1½%) of the purchase price must be paid to Seller by the Buyer for any month of fraction of a month thereafter. Seller will not be required to accept payment other than as set forth in this order. However, to avoid a late charge assessment in the event of a dispute or claimed defect in the goods (other than freight), the Buyer may withhold up to five percent (5%) of the purchase price until such time that the dispute is settled or the defect repaired, but no longer than sixty (60) days after shipment. If the disputed amount is the freight charge, the Buyer may withhold only the amount of the freight charge until the dispute is settled, but no longer than sixty (60) days after shipment.
6. **DELIVERY OF GOODS**
The goods will be delivered within reasonable time of the Buyer's acceptance of this offer. The goods are offered F.O.B., Seller's factory. Seller, in its sole discretion, will determine and arrange the means and manner for transportation of the goods. Buyer is to pay all costs of shipping and insurance, and shall assume all risk of loss in accordance with Paragraph 12. Shipping charges for domestic shipments will be prepaid and added to the invoice, unless otherwise indicated. The goods will be shipped under a straight bill of lading naming the Buyer as consignee. All special handling charges shall be borne by Buyer.
7. **STORAGE CHARGES**
Shipments delayed by Buyer beyond scheduled shipment date shall be assessed a one and one-half percent (1½%) per month storage charge for any month, or portion of a month, beyond the scheduled shipment date.
8. **SHIPMENT OF INSTALLMENTS**
Seller reserves the right to make delivery in installments. Delay in shipment of any installment shall not relieve Buyer of its obligations to accept remaining shipments or shipments under other orders.
9. **DELIVERY NOT IN DISPUTE**
Any delivery not in dispute shall be paid regardless of other controversies relating to other delivered or undelivered goods. Buyer shall waive failure in shipment or delivery of shortages unless Buyer files a written claim with Seller within ten (10) days after delivery of the goods hereunder.
10. **INCREASED FREIGHT**
Any increase in freight rates between the date of quotation, which includes transportation costs, and the shipment date shall be borne by Buyer and shall appear as a separate item on the invoice.
11. **PACKAGING OF GOODS**
Seller will package and prepare the goods for shipment in accordance with its normal procedures. If Buyer requests or requires any additional packaging or preparation other than in conformity with Seller's normal procedure, Buyer will pay the costs of such additional packaging or preparation, which will be added to and paid in accordance with the purchase price for the goods. Packing for return shipments to Seller must, at a minimum, meet Seller's normal packaging standards. Returned equipment shall remain the property of Buyer and shall be at Buyer's risk until received in Seller's possession.
12. **RISK OF LOSS**
Risk of loss of the goods will pass to the Buyer upon identification of the goods. Identification of the goods will occur upon receipt of a purchase order by Seller from the Buyer. At its own expense, Buyer will purchase and maintain in full force and effect adequate insurance covering risk of loss of the goods, payable to Seller as its interest may appear, for the period, which ends on the payment in full of the purchase price for the goods. If Buyer fails to obtain and keep such insurance in full force and effect, Seller may take out such insurance and pay any premium due or to become due thereon that may remain unpaid, and such amount so paid shall be repaid to Seller by Buyer, or Seller may, at its option, terminate this order by written notice. It is also agreed that Buyer, at its own expense, will and independently seek, adequate insurance coverage with respect to Buyer's interest in the goods, and Buyer shall not look to Seller for deficiency in insurance coverage, notwithstanding the fact that Buyer may have the right of rejection, or that Seller may be in such default as to constitute a breach.
13. **CONFIDENTIALITY**
Drawings, specifications and other information submitted with the Seller's goods or quotation marked as proprietary are confidential to Seller and may not be disclosed to any other party. Such drawings, specifications and other information are for evaluation purposes only and shall not be deemed to form part of the purchase contract or quote.
14. **EXCUSED FROM NON-PERFORMANCE**
The Seller shall not be liable for any failure to deliver or delay in the performance of orders, contracts, or Agreements, or in the delivery or shipment of goods, or for any loss or damages suffered by the Buyer by reason of such delay, when such delay is, directly or indirectly, caused by, or in any manner arises from fires, floods, accidents, riots, acts of God, war, governmental interference, statutes, ordinances, regulations, embargoes, strikes, labor difficulties, shortage of labor, fuel, power, materials or supplies, delay or default of common carriers, transportation delays, or without limiting the foregoing or any other cause or causes, whether or not similar in nature to any of those herein before specified or within or without the United States which are beyond its control. All orders or contracts are accepted with the understanding that they are subject to the Seller's ability to obtain the necessary raw materials, and all orders or contracts as well as shipments applicable thereto are subject to the Seller's current vendor schedules, failure or curtailment in the Seller's usual sources of supply, governmental priorities, and other government regulations, orders, directions, and restrictions which may be in effect from time to time which the Seller in its judgment and discretion deems advisable to comply as a public or patriotic duty. Buyer further agrees and affirms that this order is subject to the prompt and timely delivery to Seller of all information requested of Buyer by Seller or required of Buyer by contract, and any delay, failure or conflict arising from such delivery or non-delivery of information will be justification for non-performance by Seller under this paragraph. The Seller shall have the additional right, in the event of the occurrence of any of the above contingencies, at its sole option, to cancel this Agreement or any part thereof without any resulting liability or extend the date of delivery for a period equal to the time actually lost by reason of the delay. Seller to the best of its knowledge and belief is complying with all laws, orders and regulations applicable to the manufacturing of the ordered goods. Seller has no duty to insure and has not advised Buyer on compliance with any laws, orders or regulations applicable to the use of the goods.
15. **WARRANTIES**
Goods furnished by the Seller are to be within the limits and of the sizes published by the Seller and subject to the Seller's standard tolerances for variations. All items made by the Seller are inspected before shipment, and should any of said items prove defective due to faults in manufacture or performance under Seller approved applications, or fail to meet the written specifications accepted by the Seller, they will be replaced or repaired by Seller at no charge to Buyer provided return or notice of rejection of such material is made within a reasonable period but in no event longer than one (1) year from date of shipment to Buyer, and provided further, that an examination by Seller discloses to Seller's reasonable satisfaction that the defect is covered by this warranty and that the Buyer has not returned the equipment in a damaged condition due to Buyer's or Buyer's employees', agents', or representatives' negligence and Buyer has not tampered, modified, redesigned, misapplied, abused, or misused the goods as to cause the goods to fail. In addition, this warranty shall not cover damage caused by Buyer's exposure of the goods to corrosive or abrasive environments. Moreover, Seller shall in no event be responsible for (1) the cost or repair of any work done by Buyer on material furnished hereunder (unless specifically authorized in writing in each instance by Seller), (2) the cost or repair of any modifications added by a Distributor or a third party, (3) any consequential or incidental damages, losses or expenses in connection with or by reason of the use of or inability to use goods purchased for any purpose, and Seller's liability shall be specifically limited to free replacement, or refund of the purchase price, at Seller's option, provided return or rejection of the goods is made consistent with this paragraph, and the Seller shall in no event be liable for transportation, installation, adjustment, loss of good will or profits, or other expenses which may arise in connection with such returned goods, or (4) the design of products or their suitability for the purpose for which they are intended or used. Should the Buyer receive defective goods as defined by this paragraph, the Buyer shall notify the Seller immediately, stating full particulars in support of his claim, and should the Seller agree to a return of the goods, the Buyer shall follow Seller's packaging and transportation directions explicitly. In no case are the goods to be returned without first obtaining a return authorization from the Seller. Any repair or replacement shall be at Seller's factory, and shall be returned to Seller transportation prepaid by Buyer. If the returned goods shall prove defective under this clause, they will be replaced or repaired by Seller at no charge to Buyer provided the return or rejection of such material is made within a reasonable period, but in no event longer than one (1) year from the date of shipment of the returned goods. If the goods prove to be defective under this paragraph, the Buyer shall remove the goods immediately from the process and prepare the goods for shipment to Seller. Continued use or operation of defective goods is not warranted by Seller and damage occurring due to continued use or operation, shall be for Buyer's account. Any description of the goods contained in this offer is for the sole purpose of identifying them, and any such description is not part of the basis of the bargain, and does not constitute a warranty that the goods will conform to that description. No affirmation of that fact or promise made by the Seller, whether or not in this offer, will constitute a warranty that the goods will conform to the affirmation or promise. THIS WARRANTY IS EXPRESSLY IN LIEU OF ANY AND ALL OTHER EXPRESS OR IMPLIED WARRANTIES WITH RESPECT TO THE GOODS OR THEIR INSTALLATION, USE, OPERATION, REPLACEMENT OR REPAIR, INCLUDING ANY IMPLIED WARRANTY OF MERCHANTABILITY OR FITNESS FOR PURPOSE, AND THE GOODS ARE BEING PURCHASED BY BUYER "AS IS". SELLER WILL NOT BE LIABLE BY VIRTUE OF THIS WARRANTY OR OTHERWISE FOR ANY SPECIAL, INCIDENTAL OR CONSEQUENTIAL LOSS OR DAMAGE RESULTING FROM THE USE OR LOSS OF USE OF THE GOODS.
16. **TITLE**
Title to the goods shall transfer upon shipment from Seller's factory. Seller gives no warranty that it has any title whatever to the goods or that they are not subject to a security interest, lien or other encumbrance prior to receipt.

TERMS AND CONDITIONS (continued)**17. AUTHORITY OF SELLER'S AGENTS**

No agent, employee or representative of Seller has any authority to bind Seller or form a part of this bargain with any affirmation, representation or warranty concerning the goods sold under this Agreement, unless such affirmation, representation, or warranty made by an agent, employee, or representative of Seller is specifically included within this written Agreement and signed by an officer of the Seller.

18. NO RESALE OF GOODS

In the event of rejection, Buyer shall in no event resell the goods, even in the absence of instruction from Seller. It is agreed that said goods are not perishable and Buyer shall hold the goods without charge to Seller, until such time as Seller may give the Buyer transportation instructions. Should Buyer sell the goods, such sale shall be deemed unequivocal acceptance of the goods. Where the Buyer rejects goods, which the Seller had reasonable grounds to believe would be acceptable, the Seller shall be granted a reasonable time to cure the nonconformity or substitute conforming goods.

19. RETURNED MATERIAL

Standard catalog goods accepted for credit and in excellent condition are subject to a minimum service charge of twenty-five percent (25%) of the invoice amount for restocking plus all transportation charges. Goods built to order are not subject to return for credit under any circumstances. Goods must be received in good condition to receive credit.

20. INSPECTION

Buyer will have the right to inspect the goods on tender by Seller. If Buyer receives the goods or takes possession of them without inspecting, this will constitute a waiver of its right to inspect. Further, Buyer will have the opportunity, at the time and place of inspection, and at its sole expense, to run adequate tests to determine whether the goods are defective. If the Buyer is to use a portion of the goods for the purpose of test and evaluation and said testing damages the goods, the Buyer shall compensate Seller, at the contract prices, for all goods so damaged, although the goods are rejected or unacceptable to buyer. Any expenses incurred by Buyer in the inspection and testing of the goods whether at Seller's factory or elsewhere will be paid by Buyer, whether or not the goods are rejected as defective. In the event Buyer rejects any shipment of goods, it may elect to retain a part of the shipment and return the balance.

21. SUB-SUPPLIER TERMS

Seller shall not agree to burden its sub-Suppliers with any of Buyer's Terms and Conditions, unless separately acknowledged in writing by an executive officer of Seller.

22. DEMAND FOR ASSURANCE OF PERFORMANCE

If at any time the financial responsibility of the Buyer becomes impaired or unsatisfactory to the Seller, or in the Seller's opinion, inadequate to meet the obligations hereunder or the Buyer fails to make any payments in accordance with the terms and provisions hereof, the terms of credit may, at Seller's option, be changed or withdrawn, and if withdrawn the Seller at its option may require cash or satisfactory security before making shipments or deliveries under this order or subsequent orders.

If any of the following events occur, but not exclusively, Buyer's financial responsibility shall be deemed as impaired or unsatisfactory and Seller will have the immediate right to demand assurance from Buyer that payment in full for the goods will be made:

- (A) Buyer fails to meet its obligations with its other suppliers as they occur.
- (B) A judgment is entered against Buyer in any court of competent jurisdiction, whether or not such judgment is stayed pending appeal.
- (C) Buyer suffers a business or financial loss due to a labor dispute, fire, flood, riot, war, embargo, act of God, default of a common carrier, or default of a customer.
- (D) Buyer fails to purchase and maintain adequate insurance coverage for the goods as required by this Agreement.
- (E) Buyer appears to breach an Agreement with Seller.
- (F) Any other reasonable grounds for insecurity of Buyer's non-performance.

In the event Buyer becomes insolvent before delivery of the goods, he will notify Seller. A failure to notify Seller shall be construed as reaffirmation of Buyer's solvency at the time of delivery. It is also agreed that upon failure of the Buyer to pay any amount when due or upon any breach of contract by Buyer, or if the Seller is insecure for any reason, the Seller may at its option, without prejudice to any other lawful remedies available to it, suspend further shipments and deliveries under this order and recall goods in transit, retake same, and repossess all goods, which may be stored with Seller for the Buyer's account, without the necessity of taking any other proceedings, and the Buyer consents that all the goods so recalled, retaken or repossessed shall become the absolute property of the Seller, and no forbearance, course of dealings, or prior payment shall affect this right of the Seller. On proper demand for assurance by Seller, Buyer will within five (5) days after receipt thereof furnish, in an amount sufficient to secure the full payment of the balance of any monies due hereunder on account of the purchase price, either a penalty bond issued by a competent surety company, or post securities or other liquid collateral to be held on account by Seller, to secure the payment of the purchase price for the goods. Buyer's failure to do so will terminate Seller's obligations under this Agreement.

If Buyer becomes bankrupt or insolvent during the period covered by this Agreement and Seller terminates this Agreement in accordance with this clause, Seller shall be entitled to such amounts as are then due under this Agreement. The foregoing shall not be construed as limiting, in any manner, any of the rights or remedies available to Seller because of any default of the Buyer under the Uniform Commercial Code as enacted and in force in the State of California on the date of this Agreement.

23. SOLVENCY OF BUYER

By acceptance of this offer, Buyer represents that it is able to pay its debts as they become due, is in fact now paying its debts in the ordinary course of business, is not insolvent within the meaning of the Federal Bankruptcy Act and, has not made an assignment for the benefit of creditors. Buyer makes these representations with full knowledge that Seller is relying thereon in extending credit under this offer or subsequent order.

24. TERMINATION

Buyer will strictly observe and comply with all Federal, state, and local laws, ordinances, and regulations, which may govern the manufacture, sale, handling, use and disposal of the goods. If Buyer violates any such laws, ordinances, or regulations or is *officially charged with such violation to the detriment or damage* of Seller, Seller in its sole discretion may immediately terminate this Agreement and any other existing agreements with Buyer and may refuse to deliver the goods, without prejudice to such other remedies as the Seller may be entitled thereto.

25. INDEMNIFICATION

Seller (including its parent, affiliates, or subsidiaries) will not have any liability for liquidated damages, or for collateral, indirect, consequential, or special damages, including loss of profits or loss of use, for breach of this Agreement or otherwise and the aggregate total liability of any damages under this Order shall in no event exceed the contract price of the individual Article giving rise to the claim (or claims) of liability, whether resulting from delays in delivery or performance, breach of warranty, claims of negligent manufacturing, patent or copyright infringement, or otherwise. Buyer agrees to indemnify and hold harmless Seller from all claims by third parties, which extend beyond the foregoing limitations of Seller's liability.

26. DEFECTIVE GOODS

In the event any of the goods sold under this Agreement shall allegedly be defective in any respect whatsoever, Buyer shall indemnify and save harmless Seller from all loss or the payment of all sums of money by reason of accidents, injuries or damages to persons or property that may happen or occur in connection with the use or sale of such goods whether or not such goods are found to be defective or otherwise, and the Buyer's sole remedy shall be as appears herein.

27. REMEDIES OF SELLER

In case of breach by Buyer, Buyer shall be liable for all lost profits of Seller, together with all other rights and remedies of Seller specifically reserved herein or as generally available.

28. EFFECT OF AGREEMENT

This order is intended as a final expression of Seller's and Buyer's Agreement and is intended also as a complete and exclusive statement of the terms of their Agreement. No course of prior dealings between Seller and Buyer and no usage of the trade and no Terms & Conditions on any confirmation order, acceptance or acknowledgment by Buyer will be relevant or admissible to supplement or explain any term used in this Agreement. Acceptance of or acquiescence in, a course of performance rendered under this, or any prior Agreement, will not be relevant or admissible to determine the meaning of this Agreement even though the Buyer has knowledge of the nature of the performance and opportunity for objection. If the Buyer's order form and/or specifications are used for the purpose of accepting an offer tendered by Seller, the terms and conditions set forth in Seller's offer will control and govern insofar as such terms and conditions may in any way conflict with the terms and conditions set forth in such order form or specifications, unless Seller otherwise consents in writing, and the issuance of such order by Buyer will operate as acceptance by Buyer of Seller's terms. No representations, warranties, understandings, or agreements have been made by Buyer or relied upon by Buyer in the making and acceptance of this Agreement other than those specifically set forth in this Agreement.

29. WAIVER

No claim or right of Seller arising out of a breach or default of this Agreement by the Buyer can be discharged in whole or in part by a waiver or renunciation of the claim or right unless Seller's waiver or renunciation is supported by consideration and is in writing signed by an officer of Seller. Any waiver by the Seller will not be deemed a waiver by Seller or any breach or default of this Agreement by the Buyer, which occurs thereafter.

30. ASSIGNMENT AND DELEGATION

No assignment of any right or interest or delegation of any obligation or performance of the Buyer under this order may be made without the prior written consent of Seller. Any attempt assignment or delegation will be wholly void and totally ineffective for all purposes.

31. INSTALLATION CHARGES

The Buyer will pay all costs and expenses incurred, whether by Seller or Buyer, for the installation, and maintenance of the goods, including but not limited to, costs and expenses of the services of Seller's employees or representatives, special tooling, dies and fixtures, and additional engineering.

32. ADVICE OF SELLER

The advice of the technical staff of Seller is available to the trade at a reasonable cost, but the Seller, not controlling or supervising the subsequent manufacture, fabrication, or installation of goods or their use after sale, does not warrant or guarantee such advice.

33. TAXES

The purchase price for the goods is exclusive of any and all federal, state, and local taxes, including but not limited to, sales, use, excise, income, occupation, or other taxes. Whenever applicable or practicable, such taxes will be added to the invoice as a separate charge to be paid by the Buyer, or in lieu thereof the Buyer will provide Seller with a tax exemption certificate acceptable to the relevant taxing authorities.

34. PATENT INFRINGEMENT

In the event Buyer provides material, specifications, drawings, instructions or the like, or Buyer uses the goods with another article or material or in a particular manner not specified by Seller, Buyer agrees to defend, protect and hold harmless Seller from and against any and all suits at law or in equity, and from all damages, claims, and demands for actual or alleged infringement of any United States or foreign patent, and to defend any suit or actions and reimburse all attorney's fees incurred by Seller in defense of such suits or actions which may be brought against Seller for an alleged patent infringement because of the manufacture and/or sale of the goods in accordance with Buyer's instructions, specifications, drawings, or the like, or use of material provided by Buyer.

TERMS AND CONDITIONS (continued)

Further, the Buyer will hold Seller free and harmless from, and release and not make claim or suit against Seller because of any suits, claims, losses, or other liability made against, or suffered by, the Buyer arising from any claim or infringement of patent, copyright, trademark, or other proprietary right, at common law, or claim of unfair trade or of unfair competition, resulting from, or occasioned by, the Buyer's use, possession, sale, manufacture, or delivery of goods made by Seller to Buyer's instructions, specifications, drawings or the like. The Buyer will notify Seller in writing of the commencement of any suit against the Buyer covered by this paragraph.

In case the goods, or any part thereof, are held to constitute an infringement and the use of such goods enjoined, the Buyer shall hold the Seller harmless and shall not make claim against Seller for non-infringing goods or procure for Buyer the legal right to continue using said goods. Seller will have the right to participate in any suits or actions described in this paragraph, and no settlement, discontinuance or judgment may be entered without advising and consulting with Seller.

35. CANCELLATION OF ORDER

The Buyer will be obligated to accept any goods shipped or delivered by Seller prior to cancellation, suspension or extension of the order. Any reduction in quantities ordered shall constitute a partial cancellation subject to this paragraph. Any attempt by Buyer to unilaterally revoke acceptance for any reason whatsoever after it has accepted any

shipment, shall constitute a breach of this Agreement. For purposes of this paragraph, acceptance shall be any waiver of inspection, use or possession of goods, payment of the invoice, or any indication of exclusive control exercised by Buyer.

36. GOVERNING LAW

This Agreement will be construed and governed by the Uniform Commercial Code as adopted in the State of California as effective and in force on the date of this Agreement, and by the laws of the State of California. All rights and remedies afforded Seller under this Agreement or the Uniform Commercial Code shall be cumulative.

37. LOCATION OF LEGAL PROCEEDINGS

If legal or arbitration proceedings are necessary to enforce this Agreement, the proceedings shall occur in the county of residence of Fluid Components International LLC, San Diego County, State of California.

38. DRAWINGS AND SPECIFICATIONS

Seller may retain for its records and for its use, a copy of all drawings, specifications, operation manuals, and other documentation produced by it on behalf of the Buyer with respect to the manufacture, installation and use of the goods. All templates, gauges and other equipment used by Seller in the manufacture of the goods will remain the sole and exclusive property of Seller. Furthermore, all drawings, specifications, materials and equipment furnished by the Buyer to Seller for use in the manufacture of the goods will be retained by and become the property of Seller.

39. GENERALLY REFERENCED SPECIFICATIONS

All generally referenced documents, drawings, catchall requirements, specifications, and the like are acceptable only to the extent applicable portions of the generally referenced documents, are specifically cited within the body of the order or cognizant specification.

40. USE OF BUYER'S NAME

If Buyer accepts this offer, Seller will have the right to use and identify the Buyer's name, and Buyer's application of Seller's product, in any of Seller's advertising materials or literature.

41. ARBITRATION

Unless otherwise provided in this Agreement, any controversy or claim arising out of or relating to this Agreement, or breach of this Agreement, will first be submitted to mediation, and if that should fail, to arbitration in accordance with the Rules of the American Arbitration Association, and judgment upon the award rendered by the arbitrators may be entered in any court having jurisdiction of the controversy or claim.

42. LITIGATION COSTS

If any litigation or arbitration is commenced between Seller and the Buyer, or their personal representatives, concerning any provision of this Agreement, the party prevailing in the litigation or arbitration is entitled, in addition to such other relief that is granted, to a reasonable sum as and for their costs and attorney's fees incurred in such litigation or arbitration.

43. EXPORTS

Purchaser hereby agrees to comply fully with all applicable U.S. [and non-U.S.] sanctions and export control laws and regulations, including without limitation those regulations maintained by the U.S. Treasury Department's Office of Foreign Assets Control ("OFAC"), Department of State's International Traffic in Arms Regulations ("ITAR"), and the U.S. Commerce Department's, Bureau of Industry and Security ("BIS"). Specifically, Purchaser covenants that it shall not—directly or indirectly—sell, provide, export, re-export, transfer, divert, loan, lease, consign, or otherwise dispose of any product, services, software, source code, or technology (collectively, "Products") received from Fluid Components International LLC. ("Seller") under this Agreement to any person, entity, or destination, or for any activity or use prohibited by the laws or regulations of the United States [or any other country], without obtaining prior authorization from the competent government authorities as required by those laws and regulations.

To the extent required under U.S. law, Purchaser further covenants to screen all customers and business partners against all relevant U.S. Government lists of persons denied export privileges or otherwise subject to trade, export, or financial sanctions, before providing or agreeing to provide any Products to any person.

Purchaser's breach of this sanction and export compliance provision(s) shall constitute cause for immediate termination of this Agreement. Purchaser agrees to indemnify and hold harmless Seller for Purchaser's non-compliance with these controls in connection with the Products. This provision shall survive termination or cancellation of this Agreement.

44. SEVERABILITY

If any of the provisions, or portions thereof, of this Agreement is held to be unenforceable or invalid by any court of competent jurisdiction, the validity and enforceability of the remaining provisions, or portions thereof, will not be affected, impaired or invalidated.

45. CAPTIONS

The subject headings of the paragraphs of this offer are included for purposes of convenience only, and will not affect the construction or interpretation of any of its provisions.

ProSpec™ 5033 Gas Delivery Systems High Flow/High Purity Switchover System

The 5033B and 5033S Series high flow/high purity changeover systems are designed to provide continuous supply of high purity gases to the laboratory, process or instrument. The 5033 Series incorporates two regulators set at different delivery pressures, and a primary outlet pressure regulator.

Basic Functional Description

When primary supply to the changeover (primary) is consumed, the secondary supply (reserve) feeds the downstream process. By turning the regulator lever counter clockwise, the primary supply can then be replenished. When the reserve is depleted the primary will then begin to feed the process. With a counter clockwise turn of the changeover regulator handknob, the reserve side can then be replenished.

Typically the 5033 Series are used with liquid dewars. The standard models come with flexible, all stainless steel (Monel® lined for oxygen service) pigtails with armor casing. The CGA connection on each pigtail has a check valve in the gland to help prevent contamination and minimize purging requirements.

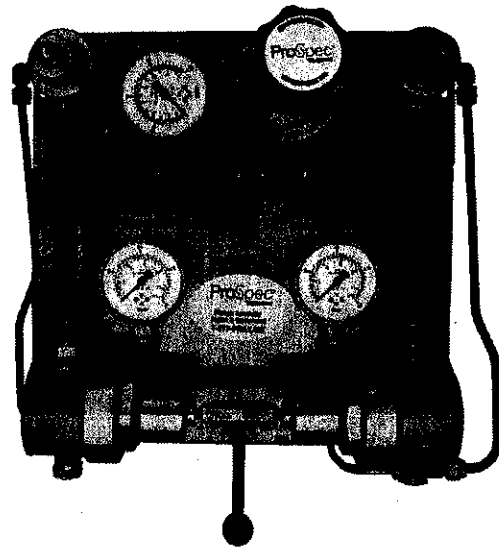
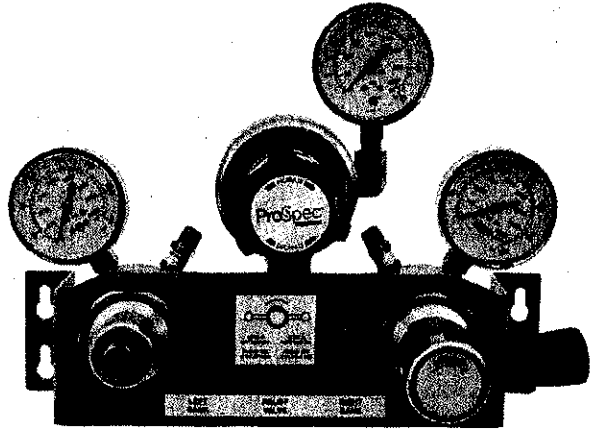

Features and Benefits

- **High Purity Diffusion Resistant Regulators**
 Minimize the diffusion of air, no possibility of gas contamination
- **User Friendly Priority Lever**
 One lever switches cylinder priority
- **Check Valves in Inlet CGA Gland**
 Designed to prevent contamination and back flow
- **Modular Construction**
 Allows for easy installation, modular design for a smaller foot print

Specifications

- **Maximum Inlet Pressure**
 3000 psig (210 bar)
 Gauge: 0-4000
 Ports: 1/2" NPTF
- **Temperature Range**
 -40 °F to 165 °F
 (-40 °C to 74 °C)
- **Gauges**
 2" diameter brass
- **Outlet Pressure Ranges**
 0-125 psig
 0-250 psig
 0-500 psig
- **Helium Leak Integrity**
 1 x 10⁻⁶ scc/sec
- **Weight**
 10.0 lb
- **Cv**
 1.8
- **Flow**
 up to 5500 SCFH (air)

Materials

- **Bodies**
 Brass barstock
- **Diaphragms/Spring**
 316 stainless steel
- **Seat**
 PTFE
- **Seal**
 PTFE
- **Filter**
 10 micron

Ordering Information – Series PRS5033-ABC-CGA

A	B	C	CGA
Material of Construction	Outlet Pressure	Assembly	Pigtail
B: Brass	0: 0- 125 psig	0: Standard Assembly	Please specify CGA
S: Stainless Steel	1: 0-250 psig	1: Audio/Visual Alarm	
	2: 0-500 psig		

1. Description

The gas alarm unit BA 12-10 or SK-10 monitors 10 inductive or magnetic snap-gauge and whose contacts are normally closed. This description also applies to the unit with 6 (BA 12-06 or SK-06) and 2 (BA 12-02 or SK-02) channels. These variants differ only in the smaller number of input terminals. Opens a contact or several contacts open, because a lack of gas is present, it indicates the lack of gas detection equipment for this deficiency audibly and visually. This message or messages can with the "buzzer stop" - to acknowledge button and forwarded via potential-free relay contacts to external devices.

2. Front view of the BA 12-10

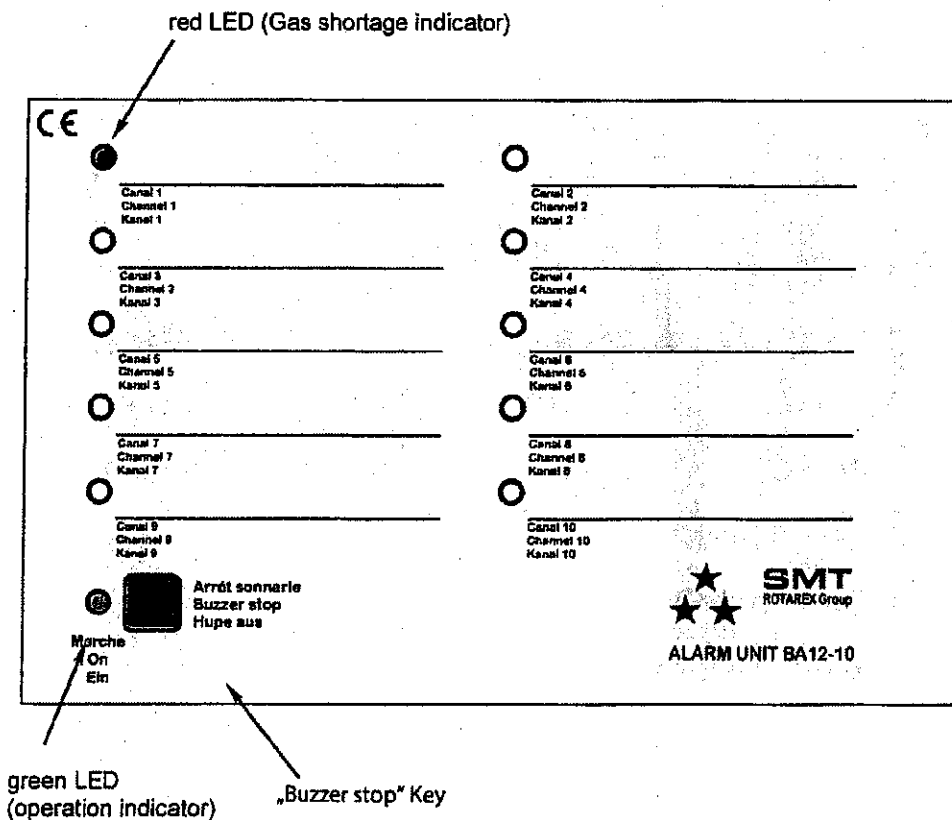

5. Connection plan (PCB Top View)

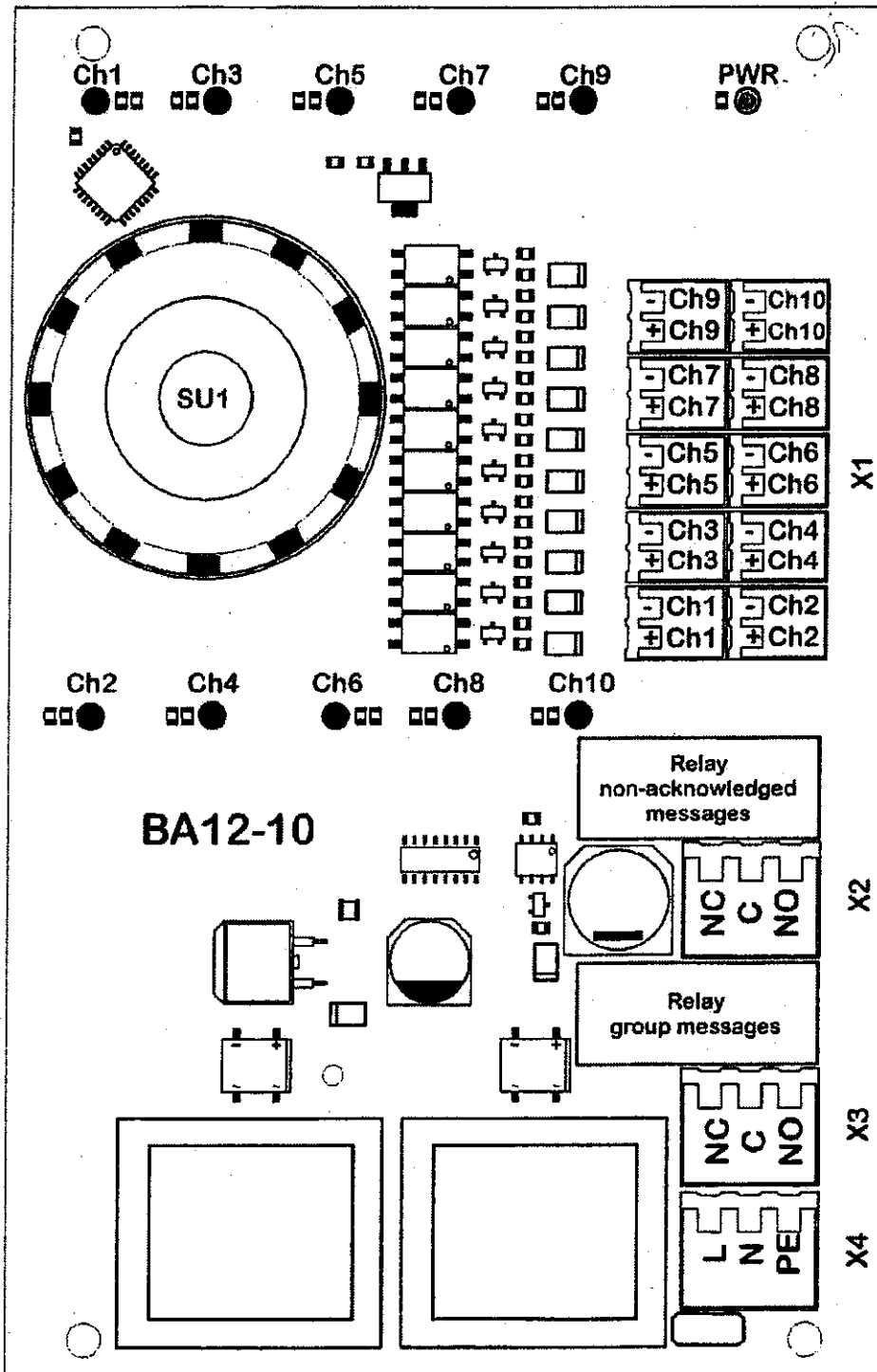

X1 Gas pressure gauge

X2 Relay non-acknowledged messages permanent failure relay contact

X3 Relay group messages failure relay contact

X4 Power 115v

7. Warning notices

7.1 Danger of the devices

The products distributed by SMT gas monitoring equipment is manufactured in accordance with generally accepted technical standards of the electronics industry and tested. If used properly, the devices are safe to operate. The units may be operated in a perfect condition in accordance with the instructions.

To incorrect operation or incorrect commissioning / installation

- hazards to life and limb of the user
- Damage of devices and other property of the user
- device malfunctions

result.

7.2 Permitted users

All persons involved with the installation, commissioning, operation, maintenance and repair of the devices must

- be qualified,
- follow the operating instructions carefully and
- the recognized rules for occupational safety

observe.

The devices may be installed only by trained personnel and put into operation. Electrical work must be performed by trained VDE-compliant electricians. Untrained personnel should work under the supervision of trained professionals in the products. The system installer must match the operator's manual to make available. Installer and user must read the manual and this safety information before beginning their work and understood. The minimum age for user is 18 years.

7.3 Intended Use

The unit of BA 12 is exclusively suitable for the monitoring of contact pressure gauges in normal rooms without explosion area and therefore does not in potentially explosive atmospheres environments.

In potentially explosive atmospheres rooms must be explosion-proof pressure transmitter with a certificate of EC approved test centers for use in Ex rooms are used. This certificate does not say anything about the function, but merely indicates that the sensor is explosion protected.

The device BA 12 must be located outside the explosion protected area.

When using the devices to local conditions must be observed. The technical data of the corresponding environmental conditions for the operation of the equipment must be maintained.



October 25, 2019

Bartlett & West

Attention: James Krumwied

RE: Instrument Air Compressor Skid

James,

Thank you for the opportunity to provide you with this quotation. Please review the following pages of this proposal that detail the equipment and scope of supply for this project.

Best Regards,

Steve Rasmussen
Sales Engineer
Rasmussen Air & Gas Energy
Steve.Rasmussen@RAGE-Energy.com
C: (402) 366-7271

Rasmussen Air & Gas Energy
655 S. 240th Street
Waterloo, NE 68069

Ph. 877-939-1999
www.RAGE-ENERGY.com

rasmussen

air & gas energy

manage flow maximize profits.

Sullivan Palatek 10M

Capacity:	38 CFM
Pressure:	125 PSI
Motor Power:	10 HP
Motor Speed:	3450
Motor Enclosure:	TEFC
Sound Data:	74 dB(A)
FLA @ 460V:	11.6
Integrated Moisture Separator:	Yes
Microprocessor Controller:	Yes

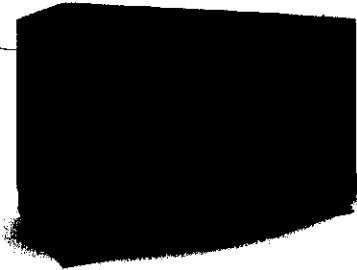

Image for reference only, final package will be mounted on a 120 Gallon Tank.

Product Description:

Sullivan Palatek is one of the last privately held, US based compressor manufacturer. All engineering and construction of these units is completed in Michigan City, Indiana. Sullivan Palatek is known in the industry for making slow turning, reliable, robust compressed air systems.

Scope of Supply:

The quoted unit is Sullivan Palatek's top of the line M series compressor. This configuration is a packaged oil flooded rotary screw compressor with sound enclosure mounted on a 120 Gallon tank. This unit is configured with a TEFC motor, a microprocessor controller in a NEMA 4 enclosure with auto restart after power failure.

Price as described: \$11,600

Rasmussen Air & Gas Energy
655 S. 240th Street
Waterloo, NE 68069

Ph. 877-939-1999
www.RAGE-ENERGY.com

rasmussen

air & gas energy
manage flow maximize profits.

ZEKS Compressed Air Solutions **800ZHA Heated Desiccant Air Dryer**

Technical Information:

Capacity:	40 CFM
Desiccant (Lbs.):	504 / Tower
Electrical:	120/1/60
Connection Size:	3/4" NPT
Dimensions:	22" W x 44" H x 15" D
Weight:	265 Lbs.

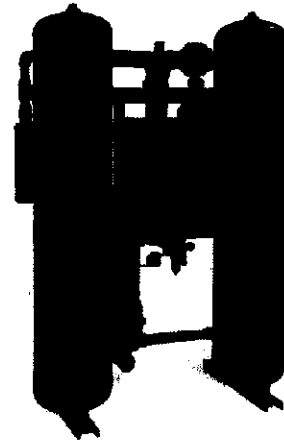

Scope:

Unit shall be factory assembled, self contained and completed in all respects including component equipment, interconnection piping, wiring, controls, and instrumentation. Unit shall be free standing, requiring only inlet/outlet air connections and electrical connection. All controls and instruments shall be factory set/calibrated so as to provide for "turn-key" operation.

- The portion of air used in regeneration shall be expanded to atmospheric pressure at the dry air outlet of the dryer, and routed to and through the off-line (regenerating) tower.
- Regeneration shall be accomplished by passing a portion of dry expanded air through the regenerating tower in a reverse direction of the drying flow path and then purging it to atmosphere.
- The off-line tower shall be gradually brought back up to line pressure prior to tower switch over. This shall prevent desiccant attrition and dusting and premature failure of downstream particulate filter elements.
- Velocity through the desiccant towers shall not exceed 65 fpm. This velocity shall provide adequate contact time to provide an efficient, consistent dewpoint. Pressure drop across the dryer shall not exceed 3 PSIG at design conditions.

Scope of supply:

Along with the standard items supplied with the dryer we've included the below options that will add reliability and longevity to the installation:

- NEMA 4 Electrical Panel
- Moisture Load Control with Failure to shift
 - This will control the purge of the dryer to match the demand of the system while maintaining the rated dew point
- Filter Package "A" with Bypass. This will include pre-piped pre filter and after filter with a bypass around the system

Price as described: \$6,500

Rasmussen Air & Gas Energy
655 S. 240th Street
Waterloo, NE 68069

Ph. 877-939-1999
www.RAGE-ENERGY.com



RAGE Engineered System:

We will receive all specified equipment at our Waterloo, NE fabrication facility. We will manufacture a 16' x 8' structural steel skid base for the equipment to be set on. There will be structural steel framing to support a steel roof that will cover all the equipment. The size of this skid was based on having 3' of room between each piece of equipment and having 3' all around the perimeter of the equipment so service can be completed without the risk of someone stepping off the base. The skid will be coated in a heavy-duty epoxy paint and will have fork pockets to be set in to place.

All equipment will be mounted on this skid and piped together. There will be an isolation valve on the compressor's outlet as well as a bypass around the dryer and filters. There will be mounted NEMA 4 fused disconnects for the compressor and for the dryer. These will be mounted in close proximity to each piece of equipment for serviceability. All electrical will be pre-wired from disconnects to each piece of equipment in flexible or rigid conduit. We will install an electronic drain on the compressor and the coalescing pre filter of the dryer. These drains will be plumbed to an EPA approved Oil Water Separator which will treat the condensate so the byproduct discharge condensate from the Oil Water Separator can be dumped on the ground or sent to a drain. The Oil Water Separator's discharge drain line will be plumbed to the end of the package.

Drawings will be available 2 weeks ARO.

Everything will be test run at our facilities to ensure flawless operation before shipment.

Price as described: \$12,000

Rasmussen Air & Gas Energy
655 S. 240th Street
Waterloo, NE 68069

Ph. 877-939-1999
www.RAGE-ENERGY.com

rasmussen

air & gas energy

manage flow maximize profits.

Example of a similar project:

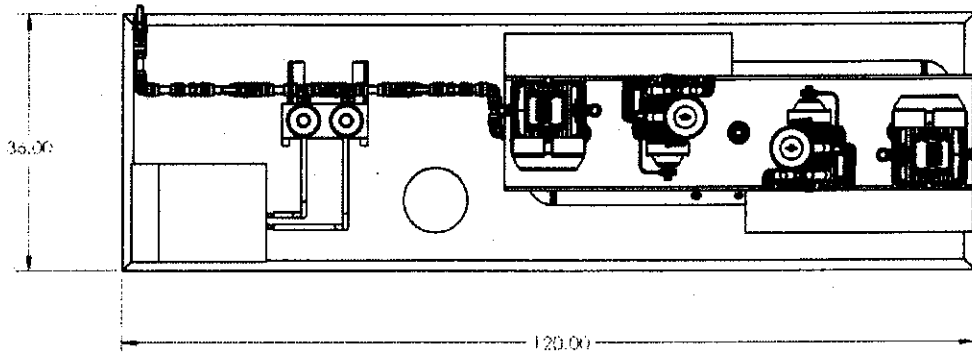
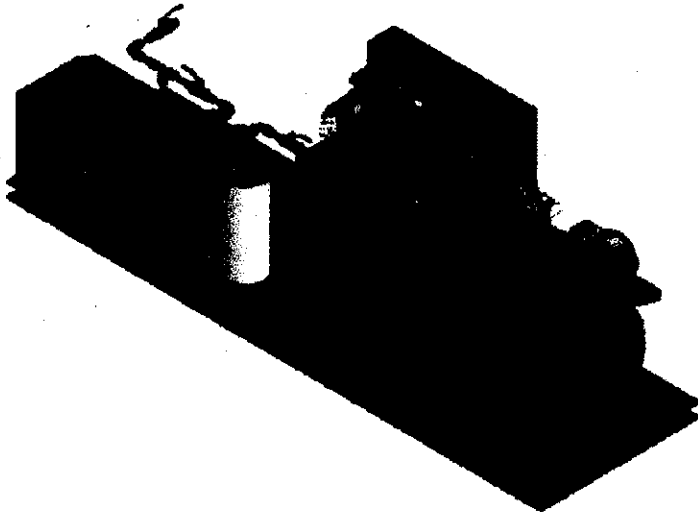

Rasmussen Air & Gas Energy
655 S. 240th Street
Waterloo, NE 68069

Ph. 877-939-1999
www.RAGE-ENERGY.com

rasmussen

air & gas energy
manage flow maximize profits.

Pricing:

Description	Price/Each	Qty	Total
Sullivan Palatek 5M Rotary Screw as described	\$11,600	1	\$11,600
ZEKS 40MPS Desiccant Dryer as described	\$6,500	1	\$6,500
Engineered Skid as described	\$12,000	1	\$12,000
			\$30,100.00

** Factory Authorized Start-up & Training is available upon request

Rasmussen Air & Gas Energy
655 S. 240th Street
Waterloo, NE 68069

Ph. 877-939-1999
www.RAGE-ENERGY.com



Notes:

- Proposal Includes: Everything specifically called out in this proposal
- Proposal excludes: Anything not specifically called out in this proposal
- Excludes: Mechanical / Electrical Installation
- Applicable taxes not included
- Freight: FOB Origin, Prepay & Add

Thank you for the opportunity to provide you with this proposal. Please carefully review this document and contact me with any questions. A signature below is necessary to confirm that we meet your requirements and that you understand our terms and conditions.

Signature: _____
PO#: _____

Best Regards,

Steve Rasmussen
Sales Engineer



402.366.7271 (cell)
402.614.9926 (main)
402.817.3751 (fax)
steve.rasmussen@rage-energy.com
www.rage-energy.com

Rasmussen Air & Gas Energy
655 S. 240th Street
Waterloo, NE 68069

Ph. 877-939-1999
www.RAGE-ENERGY.com



TERMS & CONDITIONS OF SALE

(Our manufacturer's terms and conditions, if attached, are a part of this quotation)

PRICES

Prices do not include sales, use, excise or similar taxes. The amount of any such tax shall be the responsibility of and paid by the purchaser, unless the purchaser shall provide the seller with a tax-exemption certificate, acceptable to the taxing authorities. All items quoted are in the standard manufacturer's configuration unless options are shown "as included" and itemized. All items quoted are quoted F.O.B. Factory, unless specifically stated otherwise in our proposal. Freight charges will be collect to customer. No installation, anchorage, or start up services are included.

TERMS

All terms are NET 30 days, unless specifically stated otherwise. Our invoices are subject to a 1.5% service charge monthly on all balances past the due date. We reserve the right to adjust prices to those in effect at the time of shipment.

On all orders exceeding \$35,000.00 a special codicil is added requiring 30% of the final invoice to be paid on order placement, 60% paid two weeks prior to final shipment, and the remaining 10% balance due net 10 days after shipment. Upon request the final 10% may be paid half in ten days and the remaining half upon start-up and training completion, provided it does not exceed 45 days.

CANCELLATION

Quotations are made with the mutual understanding that orders are not subject to cancellation, unless the buyer accepts the standard 20% cancellation charge. A verbal or formal purchase order constitutes a commitment regardless of the absence of formal acceptance on the part of Rasmussen Air & Gas Energy, INC.

DELIVERIES

Deliveries are approximate and will be computed from date of acceptance of order by the manufacturer and receipt of all necessary information from the purchaser. Deliveries are also subject to the following:

- Prior sale and confirmation at time of order acceptance.
- Delays caused by strikes, fires, accidents or other factors not within our reasonable control.
- Any changes that may be caused by procedures or priorities set up by the U.S. Government.

LIMITATIONS

The seller shall in no event be liable for any consequential or indirect damages on account of accidents or delays regardless of the cause, nor damages due to negligence or breach of warranty by the manufacturer. Order placement constitutes acceptance of all terms and conditions of the above.

Rasmussen Air & Gas Energy
655 S. 240th Street
Waterloo, NE 68069

Ph. 877-939-1999
www.RAGE-ENERGY.com



BOND RIDER

Bond Number 24061697

To be attached to and form a part of Bond Number 24061697 dated the 10th day of January, 2019, issued by Liberty Mutual Insurance Company, as Surety (the "Surety"), on behalf of The Ashton Company, Inc., Contractors and Engineers, as Principal (the "Principal") in favor of Pima County, Arizona (the "Obligee") (hereinafter the "Bond").

Whereas, upon the request of the Principal, the Bond is hereby amended to modify the penal sum as follows:

The Amount of the Bond has been changed from Seven Million Seven Hundred Thirty Thousand Six Hundred Eight Dollars And Ninety-one Cents US Dollars (\$7,730,608.91) to Twelve Million Six Hundred Twenty-two Thousand Two Hundred Thirty Dollars And Thirty-seven Cents US Dollars (\$12,622,230.37).

Nothing herein contained shall vary, alter or extend any provision or condition of this bond except as herein expressly stated.

This rider is effective dated December 2, 2019.

The Ashton Company, Inc., Contractors and Engineers
Principal

By 

Liberty Mutual Insurance Company
Surety

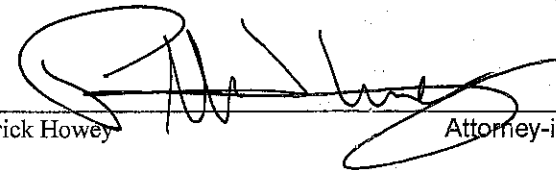
By 
Patrick Howey Attorney-in-Fact





This Power of Attorney limits the acts of those named herein, and they have no authority to bind the Company except in the manner and to the extent herein stated.

Liberty Mutual Insurance Company
The Ohio Casualty Insurance Company
West American Insurance Company

Certificate No: 8200941-969682

POWER OF ATTORNEY

KNOWN ALL PERSONS BY THESE PRESENTS: That The Ohio Casualty Insurance Company is a corporation duly organized under the laws of the State of New Hampshire, that Liberty Mutual Insurance Company is a corporation duly organized under the laws of the State of Massachusetts, and West American Insurance Company is a corporation duly organized under the laws of the State of Indiana (herein collectively called the "Companies"), pursuant to and by authority herein set forth, does hereby name, constitute and appoint, Joseph C. Dhuey, Frances Farnsworth, Patrick Howey, Tina K. Nierenberg, Tina Marie Perkins, Saralyn Seymour, Charles A. Touche, Brian D. Wilder, Andrea T. Windish

all of the city of Tucson state of Arizona each individually if there be more than one named, its true and lawful attorney-in-fact to make, execute, seal, acknowledge and deliver, for and on its behalf as surety and as its act and deed, any and all undertakings, bonds, recognizances and other surety obligations, in pursuance of these presents and shall be as binding upon the Companies as if they have been duly signed by the president and attested by the secretary of the Companies in their own proper persons.

IN WITNESS WHEREOF, this Power of Attorney has been subscribed by an authorized officer or official of the Companies and the corporate seals of the Companies have been affixed thereto this 18th day of April, 2019.



Liberty Mutual Insurance Company
The Ohio Casualty Insurance Company
West American Insurance Company

By: David M. Carey, Assistant Secretary

Not valid for mortgage, note, loan, letter of credit, currency rate, interest rate or residual value guarantees.

State of PENNSYLVANIA
County of MONTGOMERY ss

On this 18th day of April, 2019 before me personally appeared David M. Carey, who acknowledged himself to be the Assistant Secretary of Liberty Mutual Insurance Company, The Ohio Casualty Company, and West American Insurance Company, and that he, as such, being authorized so to do, execute the foregoing instrument for the purposes therein contained by signing on behalf of the corporations by himself as a duly authorized officer.

IN WITNESS WHEREOF, I have hereunto subscribed my name and affixed my notarial seal at King of Prussia, Pennsylvania, on the day and year first above written.



COMMONWEALTH OF PENNSYLVANIA
Notarial Seal
Teresa Pastella, Notary Public
Upper Merion Twp., Montgomery County
My Commission Expires March 28, 2021
Member, Pennsylvania Association of Notaries

By: Teresa Pastella, Notary Public

This Power of Attorney is made and executed pursuant to and by authority of the following By-laws and Authorizations of The Ohio Casualty Insurance Company, Liberty Mutual Insurance Company, and West American Insurance Company which resolutions are now in full force and effect reading as follows:

ARTICLE IV - OFFICERS: Section 12. Power of Attorney.

Any officer or other official of the Corporation authorized for that purpose in writing by the Chairman or the President, and subject to such limitation as the Chairman or the President may prescribe, shall appoint such attorneys-in-fact, as may be necessary to act in behalf of the Corporation to make, execute, seal, acknowledge and deliver as surety any and all undertakings, bonds, recognizances and other surety obligations. Such attorneys-in-fact, subject to the limitations set forth in their respective powers of attorney, shall have full power to bind the Corporation by their signature and execution of any such instruments and to attach thereto the seal of the Corporation. When so executed, such instruments shall be as binding as if signed by the President and attested to by the Secretary. Any power or authority granted to any representative or attorney-in-fact under the provisions of this article may be revoked at any time by the Board, the Chairman, the President or by the officer or officers granting such power or authority.

ARTICLE XIII - Execution of Contracts: Section 5. Surety Bonds and Undertakings.

Any officer of the Company authorized for that purpose in writing by the chairman or the president, and subject to such limitations as the chairman or the president may prescribe, shall appoint such attorneys-in-fact, as may be necessary to act in behalf of the Company to make, execute, seal, acknowledge and deliver as surety any and all undertakings, bonds, recognizances and other surety obligations. Such attorneys-in-fact subject to the limitations set forth in their respective powers of attorney, shall have full power to bind the Company by their signature and execution of any such instruments and to attach thereto the seal of the Company. When so executed such instruments shall be as binding as if signed by the president and attested by the secretary.

Certificate of Designation - The President of the Company, acting pursuant to the Bylaws of the Company, authorizes David M. Carey, Assistant Secretary to appoint such attorneys-in-fact as may be necessary to act on behalf of the Company to make, execute, seal, acknowledge and deliver as surety any and all undertakings, bonds, recognizances and other surety obligations.

Authorization - By unanimous consent of the Company's Board of Directors, the Company consents that facsimile or mechanically reproduced signature of any assistant secretary of the Company, wherever appearing upon a certified copy of any power of attorney issued by the Company in connection with surety bonds, shall be valid and binding upon the Company with the same force and effect as though manually affixed.

I, Renee C. Llewellyn, the undersigned, Assistant Secretary, The Ohio Casualty Insurance Company, Liberty Mutual Insurance Company, and West American Insurance Company do hereby certify that the original power of attorney of which the foregoing is a full, true and correct copy of the Power of Attorney executed by said Companies, is in full force and effect and has not been revoked.

IN TESTIMONY WHEREOF, I have hereunto set my hand and affixed the seals of said Companies this 2nd day of December 2019



By: Renee C. Llewellyn, Assistant Secretary

To confirm the validity of this Power of Attorney call 1-610-832-8240 between 9:00 am and 4:30 pm EST on any business day.



EVIDENCE OF COMMERCIAL PROPERTY INSURANCE

DATE (MM/DD/YYYY)

12/3/2019

THIS EVIDENCE OF COMMERCIAL PROPERTY INSURANCE IS ISSUED AS A MATTER OF INFORMATION ONLY AND CONFERS NO RIGHTS UPON THE ADDITIONAL INTEREST NAMED BELOW. THIS EVIDENCE DOES NOT AFFIRMATIVELY OR NEGATIVELY AMEND, EXTEND OR ALTER THE COVERAGE AFFORDED BY THE POLICIES BELOW. THIS EVIDENCE OF INSURANCE DOES NOT CONSTITUTE A CONTRACT BETWEEN THE ISSUING INSURER(S), AUTHORIZED REPRESENTATIVE OR PRODUCER, AND THE ADDITIONAL INTEREST.

PRODUCER NAME, CONTACT PERSON AND ADDRESS Lovitt & Touche, a Marsh & McLennan Agency, LLC 7202 E Rosewood Drive, Suite 200 Tucson, AZ 85710		PHONE (A/C, No. Ext): 520-722-3000	COMPANY NAME AND ADDRESS Hanover Fire & Casualty Ins Co	NAIC NO: 1078
FAX (A/C, No): 520-722-7245	E-MAIL ADDRESS: cpijanowski@lovitt-touche.com		IF MULTIPLE COMPANIES, COMPLETE SEPARATE FORM FOR EACH	
CODE:	SUB CODE:	POLICY TYPE Builder's Risk		
AGENCY CUSTOMER ID #: ASHTCOM-C1		LOAN NUMBER	POLICY NUMBER IH4D80459000	
NAMED INSURED AND ADDRESS The Ashton Company, Inc. Contractors and Engineers P O Box 26927 Tucson, AZ 85726		EFFECTIVE DATE 02/01/2019	EXPIRATION DATE 10/01/2020	<input type="checkbox"/> CONTINUED UNTIL TERMINATED IF CHECKED
ADDITIONAL NAMED INSURED(S) Contractors & Sub-contractors of every tier; Owner		THIS REPLACES PRIOR EVIDENCE DATED:		

PROPERTY INFORMATION (ACORD 101 may be attached if more space is required) BUILDING OR BUSINESS PERSONAL PROPERTY

LOCATION / DESCRIPTION
 Builders Risk Project located at 7101 N Casa Grande Hwy, Tucson, AZ. TRWRF Biogas Cleaning & Utilization Project.

THE POLICIES OF INSURANCE LISTED BELOW HAVE BEEN ISSUED TO THE INSURED NAMED ABOVE FOR THE POLICY PERIOD INDICATED. NOTWITHSTANDING ANY REQUIREMENT, TERM OR CONDITION OF ANY CONTRACT OR OTHER DOCUMENT WITH RESPECT TO WHICH THIS EVIDENCE OF PROPERTY INSURANCE MAY BE ISSUED OR MAY PERTAIN, THE INSURANCE AFFORDED BY THE POLICIES DESCRIBED HEREIN IS SUBJECT TO ALL THE TERMS, EXCLUSIONS AND CONDITIONS OF SUCH POLICIES. LIMITS SHOWN MAY HAVE BEEN REDUCED BY PAID CLAIMS.

COVERAGE INFORMATION		PERILS INSURED	BASIC	BROAD	<input checked="" type="checkbox"/> SPECIAL	
COMMERCIAL PROPERTY COVERAGE AMOUNT OF INSURANCE:		\$ 12,622,231			DED: 5,000	
		YES	NO	N/A		
<input type="checkbox"/> BUSINESS INCOME	<input type="checkbox"/> RENTAL VALUE		X		If YES, LIMIT:	Actual Loss Sustained; # of months:
BLANKET COVERAGE			X		If YES, indicate value(s) reported on property identified above: \$	
TERRORISM COVERAGE		X			Attach Disclosure Notice / DEC	
IS THERE A TERRORISM-SPECIFIC EXCLUSION?				X		
IS DOMESTIC TERRORISM EXCLUDED?				X		
LIMITED FUNGUS COVERAGE		X			If YES, LIMIT: 100,000	DED: 5,000
FUNGUS EXCLUSION (If "YES", specify organization's form used)				X		
REPLACEMENT COST		X				
AGREED VALUE				X		
COINSURANCE				X	If YES, %	
EQUIPMENT BREAKDOWN (If Applicable)		X			If YES, LIMIT: 12,622,231	DED: 5,000
ORDINANCE OR LAW - Coverage for loss to undamaged portion of bldg		X			If YES, LIMIT: Included	DED: 5,000
- Demolition Costs		X			If YES, LIMIT: 1,000,000	DED: 5,000
- Incr. Cost of Construction		X			If YES, LIMIT: 1,000,000	DED: 5,000
EARTH MOVEMENT (If Applicable)		X			If YES, LIMIT: 12,622,231	DED: 25,000
FLOOD (If Applicable)		X			If YES, LIMIT: 12,622,231	DED: 25,000
WIND / HAIL INCL <input checked="" type="checkbox"/> YES <input type="checkbox"/> NO Subject to Different Provisions:		X			If YES, LIMIT:	DED:
NAMED STORM INCL <input checked="" type="checkbox"/> YES <input type="checkbox"/> NO Subject to Different Provisions:		X			If YES, LIMIT:	DED:
PERMISSION TO WAIVE SUBROGATION IN FAVOR OF MORTGAGE HOLDER PRIOR TO LOSS				X		

CANCELLATION

SHOULD ANY OF THE ABOVE DESCRIBED POLICIES BE CANCELLED BEFORE THE EXPIRATION DATE THEREOF, NOTICE WILL BE DELIVERED IN ACCORDANCE WITH THE POLICY PROVISIONS.

ADDITIONAL INTEREST

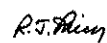
<input type="checkbox"/> CONTRACT OF SALE <input type="checkbox"/> MORTGAGEE	<input type="checkbox"/> LENDER'S LOSS PAYABLE <input type="checkbox"/> LOSS PAYEE	LENDER SERVICING AGENT NAME AND ADDRESS
NAME AND ADDRESS Pima County Procurement Department Design & Construction Division 130 W Congress Street 3rd Floor Tucson, AZ 85701-1207 United States		AUTHORIZED REPRESENTATIVE 

© 2003-2015 ACORD CORPORATION. All rights reserved.



ADDITIONAL REMARKS SCHEDULE

AGENCY Lovitt & Touché, a Marsh & McLennan Agency, LLC		NAMED INSURED The Ashton Company, Inc. Contractors and Engineers P O Box 26927 Tucson, AZ 85726	
POLICY NUMBER IH4D80459000		EFFECTIVE DATE: 02/01/2019	
CARRIER Hanover Fire & Casualty Ins Co	NAIC CODE 1078		

ADDITIONAL REMARKS

THIS ADDITIONAL REMARKS FORM IS A SCHEDULE TO ACORD FORM,
FORM NUMBER: 28 **FORM TITLE:** EVIDENCE OF COMMERCIAL PROPERTY INSURANCE

REMARKS:

ADDITIONAL NAMED INSURED:
 The following persons or organizations are included as Additional Named Insureds when you have agreed in a written contract or written agreement, executed prior to loss, to name such persons or organizations as an Additional Named Insured, but only to the extent of their financial interest in the Covered Property:
 - Owner(s) of Covered Property
 - Contractors and sub-contractors of every tier

Includes:
 \$500,000 Property at Temporary Locations
 \$500,000 Property in Transit
 \$50,000 Soft Costs

PROJECT: Solicitation NO. 285645; CT-VWV-18-423 - Design Build Services for TRWRF BioGas Cleaning & Utilization Project (3GAS18)
OWNER: Pima County, and its departments, districts, boards, commissions, officers, officials, agents and employees; Pima County Regional Wastewater Reclamation Department.