



**BOARD OF SUPERVISORS AGENDA ITEM REPORT**  
**CONTRACTS / AWARDS / GRANTS**

Requested Board Meeting Date: October 18, 2016

or Procurement Director Award

---

**Contractor/Vendor Name (DBA):** Freightliner of Arizona, LLC (Headquarters: Tolleson, AZ)

**Project Title/Description:**

Various New Trucks

**Purpose:**

Award of Contract: Purchase Order No. PO-PO-17-24. Contract is for a one-time award in the amount of \$421,254.00 for 3 trucks.

Administering Department: Fleet Services

**Procurement Method:**

Pursuant to Pima County Procurement Code 11.12.010, Competitive Sealed Bidding, Solicitation No. 229988 was conducted to satisfy the RQS No.17-17. Seven (7) bids were received. Award is to the lowest responsive and responsible bidder.

Attachments: Notice of Recommendation for Award and Offer Agreement.

**Program Goals/Predicted Outcomes:**

To acquire the best quality trucks and warranties at the best price.

**Public Benefit:**

To acquire the highest quality product for the least amount of tax dollars spent.

**Metrics Available to Measure Performance:**

The amount of hours of work performed with the trucks compared to the amount of down time for repairs and service.

**Retroactive:**

No

**Original Information**

Document Type: PO Department Code: PO Contract Number (i.e., 15-123): 17-24

Effective Date: 10/18/16 Termination Date: 06/30/17 Prior Contract Number (Synergen/CMS): \_\_\_\_\_

Expense Amount: \$ 421,254.00  Revenue Amount: \$ \_\_\_\_\_

Funding Source(s): Fleet Services Internal Service, 32%  
Transportation Operating, 68%

Cost to Pima County General Fund: N/A

Contract is fully or partially funded with Federal Funds?  Yes  No  Not Applicable to Grant Awards

Were insurance or indemnity clauses modified?  Yes  No  Not Applicable to Grant Awards

Vendor is using a Social Security Number?  Yes  No  Not Applicable to Grant Awards

If Yes, attach the required form per Administrative Procedure 22-73.

**Amendment Information**

Document Type: \_\_\_\_\_ Department Code: \_\_\_\_\_ Contract Number (i.e., 15-123): \_\_\_\_\_

Amendment No.: \_\_\_\_\_ AMS Version No.: \_\_\_\_\_

Effective Date: \_\_\_\_\_ New Termination Date: \_\_\_\_\_

Expense  Revenue  Increase  Decrease Amount This Amendment: \$ \_\_\_\_\_

Funding Source(s): \_\_\_\_\_

Cost to Pima County General Fund: \_\_\_\_\_

Contact: María Julia Canizales *Amended 10/11/16*

Department: Procurement *10/7/16* Telephone: 724-8167

Department Director Signature/Date: *[Signature]* 10/11/16

Deputy County Administrator Signature/Date: *[Signature]* 10-11-16

County Administrator Signature/Date: *[Signature]* 10/11/16  
*(Required for Board Agenda/Addendum Items)*



**NOTICE OF RECOMMENDATION FOR AWARD**

Date of Issue: September 30, 2016

The Procurement Department hereby issues formal notice to respondents to Solicitation #229988 for Various New Trucks that the following listed respondent will be recommended for award as indicated below. The award action is scheduled to be performed by the Board of Supervisors on or after October 18, 2016.

Award is recommended to the responsive and responsible bidder.

<u>AWARDEE NAME</u>	<u>BID AMOUNT</u>	<u>AWARD AMOUNT</u>
<b>Group 1:</b> Freightliner of Arizona, LLC.	\$266,324.00	\$266,324.00
<b>Group 2:</b> Freightliner of Arizona, LLC.	\$154,930.00	\$154,930.00

<u>OTHER RESPONDENT NAMES</u>	<u>BID AMOUNT</u>
<b>Group 1:</b> Arizona Truck Center dba Vanguard Truck Center of Tucson	\$284,820.00
RWC Group dba RWC International	\$286,166.82
RWC Group dba RWC International	\$280,413.24
Inland Kenworth US INC	\$294,316.00
Freightliner of Arizona, LLC. Alt. Bid #1	\$275,062.00
Freightliner of Arizona, LLC. Alt. Bid #2	\$269,372.00

<b>Group 2:</b> Arizona Truck Center dba Vanguard Truck Center of Tucson	\$162,985.00
RWC Group dba RWC International	\$164,812.14
RWC Group dba RWC International	\$164,812.14
Inland Kenworth US INC	\$170,933.00
Freightliner of Arizona, LLC. Alt. Bid #2	\$155,282.00

Issued by: Maria Julia Canizales

Telephone Number: (520) 724-8167

This notice is in compliance with Pima County Procurement Code §11.20.010(C).

Copy to: Pima County SBE via e-mail at [SBE@pima.gov](mailto:SBE@pima.gov) or via fax at 520-724-4434.



**PIMA COUNTY PROCUREMENT DEPARTMENT**  
130 W. CONGRESS ST., 3RD FLOOR, TUCSON, AZ 85701-1207  
PHONE: (520) 724-8161 FAX: (520) 222-1484

Mary Jo Furphy  
Procurement Director

---

September 13, 2016

**Addendum #1**

**IFB #229988: Various New Trucks**

Be advised of the following changes, clarifications and/or additions to the above-referenced Solicitation as stated in the following Addendum.

**SOLICITATION DUE DATE:**

Please note the Solicitation due date remains unchanged

**CHANGES AND/OR ADDITIONS:**

**REPLACE: OFFER AGREEMENT pages 1-34 from the original bid package with the following REVISED Offer Agreement pages 1-40.**

All other requirements and terms of the Solicitation remain unchanged. Failure to include acknowledgment of all addenda may be cause for rejection.

This Addendum is a total of 1 page.

If any questions, please contact me via e-mail at [maria.canizales@pima.gov](mailto:maria.canizales@pima.gov).

\_\_\_\_\_  
Maria Julia Canizales Commodity/Contracts Officer

**REVISED**

**PIMA COUNTY NOTICE OF INVITATION FOR BIDS (IFB)**

**Solicitation Number: 229988 Title: Various New Trucks**



**DUE IN AND OPENS: SEPTEMBER 22, 2016 AT OR BEFORE 11:00 A.M. LOCAL ARIZONA TIME (MST)**

**Submit Bid to:**

**Pre-Bid Conference: SEPTEMBER 1, 2016 AT 11:00 A.M. LOCAL ARIZONA TIME (MST)**

Pima County Procurement Department  
130 West Congress, 3rd Floor, Receptionist  
Tucson, Arizona 85701

Pima County Procurement Department  
130 West Congress, 3rd Floor  
Tucson, Arizona 85701

**SOLICITATION:** Pima County is soliciting bids from Respondents qualified, responsible and willing to provide the following Goods and/or Services in compliance with all solicitation specifications and requirements contained or referenced herein.

**GENERAL DESCRIPTION:** To provide **three (3) various new trucks**, per specifications and requirements defined herein.

You may download a full copy of this solicitation at [www.pima.gov/procure/ifbrfp.htm](http://www.pima.gov/procure/ifbrfp.htm) by selecting the solicitation number. **Respondents are required to check this website for addenda prior to the Due In and Opens date to assure that the bid incorporates all addenda.** Prospective Respondents may also pick up a copy, Monday through Friday excluding legal holidays, 8 am to 5 pm LOCAL ARIZONA TIME (MST), at the address listed above.

A Pre-Bid Conference will be held for the purpose of clarifying requirements and answering prospective respondent questions. It is the responsibility of Prospective Respondents to familiarize themselves with all requirements of the solicitation and to identify any issues at the conference. **Attendance is optional and encouraged.**

Bids shall be submitted as defined in the Instructions to Bidders, in accordance with the Standard Terms and Conditions, and all solicitation documents either referenced or included herein. Failure to do so may be cause for rejection as *non-responsive*.

Bidders must complete and return those documents identified in the Instruction to Bidders Submission of Bids instruction.

Bids may not be withdrawn for 60 days after opening except as allowed by Pima County Procurement Code.

**RESPONDENTS ARE REQUIRED TO READ THE ENTIRE SOLICITATION, INCLUDING ALL REFERENCED DOCUMENTS, ASSURE THAT THEY CAN AND ARE WILLING TO COMPLY, AND TO INCORPORATE ALL ASSOCIATED COSTS IN THEIR BID.**

Questions and Deviation requests shall be submitted in writing to Procurement Department, Attention: Maria Julia Canizales.

All submittals shall reference the Solicitation Number and Title; Questions or Deviation Requests submitted within 8 days of the solicitation *Due in and Opens Date* may not be answered.

**Fax:** (520) 222-1484    **email:** [maria.canizales@pima.gov](mailto:maria.canizales@pima.gov)

**USPO Mail to the following address:**

Pima County Procurement Department, 130 W. Congress, 3rd Floor, Mailstop # DT-AB3-126; Tucson, AZ 85701

**VERBAL REQUESTS FOR CLARIFICATIONS OR INTERPRETATIONS WILL NOT BE ACCEPTED.**

Maria Julia Canizales  
Commodity/Contracts Officer

**Publish:** The Territorial: August 24, 25, 26 and 29<sup>th</sup>, 2016

**INSTRUCTIONS TO BIDDERS**

FAILURE TO COMPLY MAY CAUSE THE BID TO BE IMPROPERLY EVALUATED OR DEEMED NON-RESPONSIVE

**1. PREPARATION OF RESPONSES**

All bids shall be made using the forms provided in this package. All prices and notations must be printed in ink or typewritten. **No erasures are permitted.** Errors may be crossed out and corrections printed in ink or typewritten adjacent to error and shall be initialed in ink by person signing the bid. Typewritten responses are preferred.

All bids shall as appropriate indicate the registered trade name, stock number, and packaging of the items included in the bid. Surety, if required by this solicitation, may be in the form of a bond, cashier's check or certificate of deposit made payable to *Pima County*. Personal or company checks are not acceptable.

**2. OFFER AGREEMENT (Contract) Form Various New Trucks Pages 1-40**

The attached or referenced Offer Agreement when completed, signed and submitted by the Offeror is a binding offer that results in a legal contract when accepted and executed by Pima County as defined by this solicitation. The Offer Agreement document must be completed and signed by an authorized representative certifying that the firm can and is willing to meet all requirements of the solicitation.

**Contractor Minimum Qualifications:**

Contractor Minimum Qualifications are intended to establish the respondent's capacity and responsibility for providing the services or products solicited. To be evaluated and considered for award of contract the Offeror shall submit with the Offer Agreement all documents specified in article 3. *Contractor Minimum Qualifications* of the Offer Agreement. If requested by article 3, the Offeror shall denote in article 3 of the Offer Agreement the license numbers/descriptions and other information requested

**Unit Prices & Bid Certification:**

Respondents shall fully complete and sign article 7. *Compensation & Payment* and article 15. *Bid/Offer Certification* sections of the Offer Agreement utilizing the forms provided by this solicitation.

Unless otherwise stated, a Unit Price shall be given for all items defined by the Offer Agreement Unit Prices schedule. Requested information and data shall be provided in the precise manner requested. Product descriptions shall provide sufficient information to precisely document the product being offered. All unit prices shall remain firm for the initial term of the executed agreement, with the exception that should seller during the term of the agreement offer to another buyer pricing for like or similar quantity, products or services at price more favorable than those given to Pima County ("COUNTY"), that seller shall offer same pricing to County effective on the date offered to other buyer. Unit prices given by respondent shall include all costs required to implement and actively conduct and document cost control and reduction activities. Taxes applied to the unit price and legally applicable to Pima County purchase transactions shall be separately invoiced and not included in the item unit price. Unit Prices shall include all costs incidental to the provision of the requirements defined by the solicitation and Offer Agreement and unless otherwise specified by the Delivery Article shall be F.O.B. Destination & Freight Prepaid Not Billed ("F.O.B. Destination"), no additional payments will be invoiced or paid. Unit prices shall prevail in the event of an extension error. Price each item separately. Delivery time if stated as a number of days shall mean "calendar" days.

COUNTY reserves the right to question, clarify and correct obvious errors.

**3. SPECIFICATIONS & DEVIATIONS**

The specifications included in this solicitation are intended to identify the kind and quality of goods and/or services to be provided without being unnecessarily restrictive, and as required to provide the information needed for the development of consistent and comprehensive bids, evaluation of bids and to efficiently support the subsequent ordering, invoicing and payment processes.

Items included in the bid shall satisfy all specifications and requirements set forth by the County's Offer Agreement. Equipment brand names, models and numbers, when given are intended to identify a level of quality, equivalent performance and dimensional specifications, and are for reference only, unless otherwise specified by the County's Offer Agreement. Failure to perform appropriate research, discovery, examine any drawings, specifications, and instructions will be at the respondent's sole risk.

**INSTRUCTIONS TO BIDDERS (continued)**

Deviation requests shall specifically document and clearly illustrate the deviation to the specification, or the requirement, set forth by this solicitation and fully explain the requested deviation's impact on the end performance of the item. Deviation requests shall be submitted prior to the initial solicitation due date. Requests shall be submitted as soon as is possible and not less than 8 days prior to the solicitation due date else they may not be answered or addressed

Acceptance or rejection of any deviation request shall be at the sole discretion of the County and will be made in writing by the County via specific addendum of the solicitation and Offer Agreement as applicable. Respondents shall complete article 13. *Acknowledgement of Solicitation Addenda* of the Offer Agreement prior to submission.

Bidders are advised that conditional offers or notations on the documents submitted that do not conform to or that request exceptions to the published solicitation and addenda may be considered non-responsive and not evaluated.

All equipment shall be models of current production, latest design and technology, new and unused unless otherwise specified.

Manufacturer and Contractor documentation, including and not limited to the following shall be provided by the successful respondent not later than 14 days after request by the County and at no additional cost; warranty; caution-informational warnings; recommended maintenance schedule and process; recommended spare parts list; operating, technical and maintenance manuals including drawings, if appropriate; product brochures; and material safety data sheets (MSDS).

**4. SUBMISSION OF BIDS**

Submissions are binding offers and will result in a binding contract upon acceptance by Pima County by issue of a properly executed contract document referencing said offer.

The submittal shall include all information requested by the solicitation, and utilize without modification the forms provided by the solicitation. Respondents are to complete, execute and submit one original of the following bid documents:

**SIGNED OFFER AGREEMENT with completed Item Unit Prices and documents or media defining other items within the scope of the agreement with Unit Prices and Discount Percent's, or Discounted Prices offered; Provide Addenda acknowledgement, tax, & contact information**

Bids must be received and time stamped at the specified location at or before the Bid Due Date/Time as defined by the *Invitation for Bid*. The "time-stamp" provided by the County shall be the official time used to determine the timeliness of the submittal. Bids and modifications received after the Bid Due Date/Time will not be accepted, or will be returned unopened. Timely submittals will be opened and recorded promptly after the Bid Due Date/Time.

Bids must be signed by an authorized agent of the respondent and submitted in a sealed envelope marked or labeled with the respondent firm name, solicitation number, title, solicitation due date and time, to the location and not later than the Bid Due Date/Time specified by the *Invitation for Bid*.

Bids and modifications received after the *Due In & Opens* date and time will not be accepted. Facsimiles of bids will not be accepted.

Failure to comply with the solicitation requirements, including submittals that modify the solicitation requirements, may be cause for the respondent's bid to be rejected as *non-responsive* and not evaluated.

**5. COMPLIANCE WITH AGREEMENT**

County will execute an agreement with the successful respondent by issue of a Master Agreement (MA) or Purchase Order or contract. The respondent agrees to establish, monitor, and manage an effective administration process that assures compliance with all requirements of the agreement. In particular, the respondent agrees that they shall not provide goods or services in excess of the executed agreement items, item quantity, item amount, or agreement amount without prior written authorization by amendment or change order properly executed by the County. Any items provided in excess of the quantity stated in the agreement shall be at the Respondent's own risk. Respondents shall decline verbal requests to deliver items in excess of the agreement and shall report all such requests in writing to the Pima County Procurement Department within 1 workday of the request. The report shall include the name of the requesting individual and the nature of the request.

**INSTRUCTIONS TO BIDDERS (continued)****6. INQUIRIES & NOTICE OF RECOMMENDATION FOR AWARD (NORFA)**

Results of this procurement will not be given in response to telephone inquiries. Interested parties are invited to attend the public opening at the time and date stated in this solicitation. A tabulation of submittals will be on file at the Procurement Department. No oral interpretations or clarifications made to any respondent as to the meaning of any of the solicitation documents will be binding on Pima County. If a prospective respondent believes a requirement of the solicitation documents to be needlessly restrictive, unfair, or unclear, the respondent shall notify the Pima County Procurement department in writing identifying the solicitation number, page and paragraph number and clearly stating the issue and suggested solution prior to the *Due In and Opens* date set for receipt of the bid or proposal. Responses from COUNTY will be made by written addendum and sent to all known potential respondents. Issues identified less than 8 days prior to the *Due In and Opens* date may not be answered.

Interested parties are invited to attend the public opening of submissions at the time and date stated in this solicitation.

Pima County protest procedures are defined by Chapter 11.20 of the Pima County Procurement Code, available through <http://www.pima.gov/cob/code/>. The five-day period to file a protest of the award will be measured from the date the Notice of Recommendation for Award is posted on the Pima County Procurement website at <http://www.pima.gov/procure/awards/> **without regard to whether individual notices were issued**. It is the responsibility of bidders, proposers and offerors to check the website.

**7. ORDER OF PRECEDENCE-CONFLICTING DOCUMENTS**

In the event there are variations or conflicts between these instructions and the standard terms and conditions or the offer agreement document, the standard terms & conditions and offer agreement shall govern.

**8. VENDOR RECORD MAINTENANCE**

By submitting a response to this solicitation, the submitter agrees to establish and maintain a complete Pima County Vendor record, including the provision of a properly completed and executed "Request for Taxpayer Identification Number and Certification" document (Form W-9), within ten calendar days of the solicitation due date. The Vendor also agrees to update the information within ten calendar days of any change in that information and prior to the submission of any invoice or request for payment. The preferred method for creating or updating this record is via the Internet utilizing the Pima County Vendor Self Service (VSS). The registration requires that the Vendor establish and maintain email functionality. In addition to providing the means for a Vendor to create and maintain their Vendor record, VSS also provides for email notice to the vendor regarding solicitations published by Pima County for commodities of interest as defined by the Vendor record. Internet links for Vendor Registration are located at the Procurement Internet page: <http://www.pima.gov/procure/venreg.htm>.

**9. SMALL BUSINESS ENTERPRISE (SBE) PREFERENCE**

Any contract funded in any amount with federal funds is not eligible for this preference.

For those bids that do not exceed \$500,000 per contract year, a 5% bid preference will be given to firms submitting SBE Certificates issued by the City of Tucson WITH THEIR BID; said certification is subject to verification and acceptance by Pima County. If the certification is accepted by Pima County, the bid will be evaluated at 95% of the bid amount to determine the low and responsive bid. If an award of contract is made, the contract will be formed utilizing the Unit Prices, or Lump Sum, as bid.

**To be eligible for the price preference, SBE firms must include with their bid documents a copy of their current Certification certificate** which may be acquired from the City of Tucson; Department of Procurement, (520) 837-4000, 225 W Alameda, 6th Floor, Tucson, AZ 85726-7210. Their SBE website, which typically includes an SBE Application Form and a Directory listing firms holding SBE Certification, is located at: [http://www.tucsonprocurement.com/bidders\\_SBE.aspx](http://www.tucsonprocurement.com/bidders_SBE.aspx)

The process of acquiring SBE Certification may take several weeks. Please contact the Pima County Vendor Relations Division at (520) 724-8465 for assistance or further information.

**END OF INSTRUCTIONS TO BIDDERS**  
**(Revised April 29, 2015)**



**1. INTENT:**

This document is intended to establish a discrete purchase order(s) to provide Pima County ("County") with Various New Trucks as described herein, pursuant to a resulting executed and effective agreement. It is the County's intention to award by group to the low bidder/bidders meeting terms, conditions, and specifications herein. **Potential bidders may bid on any group or all of the groups.**

**Group 1 – Two (2) New 12 Yard Dump Truck  
Group 2 – One (1) New Water Trucks**

All Goods and Services offered or provided pursuant to the resulting executed and effective agreement shall conform to the requirements defined by or referred to by the solicitation documents including *Solicitation addenda, Instructions to Bidders, Standard Terms and Conditions, this Offer Agreement, Attachment A – Detailed Specifications, Attachment B – Specification Check-List, Attachment C – Certification of Stocking, Supplying of Parts and Service Program, and Attachment D – Pricing Page*, all of which are incorporated herein.

It is the intent of all parties to this agreement that this document, including all attachments and documents incorporated by reference, constitutes the entire agreement between the parties pertaining to the subject matter hereof, and all prior or contemporaneous agreements and understandings, oral or written, are hereby superseded and merged herein. This Contract may be modified, amended, altered or extended only by a written amendment signed by the parties.

**2. CONTRACT TERM EXTENSIONS-RENEWALS & REVISIONS:**

The initial term of the agreement will be reflected by the discreet (one-time) purchase order(s).

**3. CONTRACTOR MINIMUM QUALIFICATIONS:**

Bidder certifies that they are competent, willing and responsible for performing the services or providing the products listed in accordance with all requirements of the services listed per this solicitation and the Offer Agreement. See Attachment A.

**4. PRODUCT OR SERVICE SPECIFICATIONS & SCOPE:**

Brand names and manufacturers' numbers are for reference only. The items listed are the minimum specifications for this offer. If submitting an alternate product, a published specification sheet for each product must be submitted with the completed IFB response. Pima County will have final determination on approved equals. No guarantee is made to the exact type and/or quantity of any product to be ordered. **See Attachments A & B for additional information.**

**All unit prices shall be filled in.** Failure to do so shall be cause for rejection as *non-responsive*. All pricing shall be *F.O.B. Destination & Freight Prepaid Not Billed ("F.O.B. Destination")*, delivered to and unloaded at the destination(s) defined by the Delivery article of this agreement or accepted *Order* for services or products and all freight cost shall be included in the offered Unit Price.

**5. OFFER ACCEPTANCE AND ORDER RELEASES:**

Offer(s) will be accepted and executed by the County by issue of a purchase order and effective on the document's date of issue without further action by either party. Purchase order will document the term of the agreement.

Invoice shall match the purchase order issued. Each invoice shall include the following (but not limited to): Description with quantity and part numbers, purchase order number, unit prices and total, date the items were delivered, applicable sales tax (not included in unit prices).

**Contractor is prohibited from supplying materials or services pursuant to the resulting agreement that are not documented or authorized by a Purchase Order at the time of provision.** The Contractor agrees that the County accepts no responsibility regarding this agreement for control or payment for materials or services not documented by a COUNTY Purchase Order.

The Contractor agrees to establish, monitor, and manage an effective agreement administration process that assures compliance with all requirements of the agreement.

In particular, the bidder agrees that they shall not provide goods or services in excess of the executed agreement items, item quantity, item amount, or agreement amount without prior written authorization by agreement revision properly executed and issued by the County. Any items provided in excess of that stated in the agreement shall be at the Bidder's own risk.

Bidders shall decline verbal requests to deliver items in excess of the agreement and shall report all such requests in writing to the COUNTY Procurement Department within one (1) workday of the request. The report shall include the name of the requesting individual and the nature of the request.

**6. ACCEPTANCE OF GOODS AND SERVICES:**

The County Department designated on the issued Purchase Order will accept goods and services only in accordance with this contract. Such acceptance is required prior to commencement of payment terms.

**7. COMPENSATION & PAYMENT:**

All pricing will conform to Pima County's Living Wage ordinance if applicable, including required annual adjustments of the wage.

Contractor will submit request(s) for payment or invoices to the location and entity defined by County's Purchase Order document.

All Invoice documents will reference the County's Purchase Order (PO) number under which the services or products were ordered. **ALL** Invoice line items will utilize the item description, precise unit price and unit of measure defined by the County's Purchase Order document. Invoices that include line items or unit prices that do not match those documented by the County's order or contract may be returned to Contractor unprocessed for correction. **Contractor will not accept orders, or provide services or products that cumulatively exceed the contract amount.**

Standard payment terms are net thirty (30) days from the date of valid invoice document and do not commence until the later of receipt of goods into payment system by the receiving Department and Contractor's Invoice is received and verified by County Financial Operations.

**OPTIONAL EARLY PAYMENT DISCOUNT TERM:** Pima County Administrative Procedure No. 22-35 section 2.2.4 defines County's practice regarding discounts for early payment. Contractor offers the following discounts to those prices to be used for all orders issued pursuant to this contract. County will utilize the existing payment code that best matches that offered and does not exceed the offered discount percentage. Payment days cannot be less than ten (10) calendar days. Contractor shall submit valid invoice document consistent with the associated Purchase Order (PO), to County Finance Department at least seven (7) calendar days prior to the date on which the discounted payment is due. If desired, for any order issued pursuant with this contract, Contractor may offer early payment discounts that exceed this Standard Early Payment Discount.

Standard Early Payment Discount Percent: 0 % if payment tendered within 0 Days as above

The Purchase Order (PO) issued to accept Contractor's offer will define the not to exceed amount of the contract.

The parties may negotiate and establish unit pricing in writing under the contract for items included in the scope of the contract for which unit pricing has not been previously defined.

Unless the parties otherwise agree in writing, all pricing will be *F.O.B. Destination & Freight Prepaid Not Billed ("F.O.B. Destination")*, delivered to and unloaded at the destination(s) defined by the delivery article of this contract or accepted *Purchase Order* for services or products and all freight costs must be included in the offered Unit Price.

Although State and City sales tax may not be fully or accurately defined on an order, they will be paid when they are DIRECTLY applicable to Pima County and invoiced as a separate line item. Such taxes should not be included in the item unit price.

Price Warranty. Contractor will give Pima County the benefit of any price reduction before actual time of shipment.

Price Escalation. All unit prices include compensation for Contractor to implement and actively conduct cost and price control activities. Pricing will remain firm during the initial year of the contract term after which the parties may consider price increases no more frequently than once per year. Contractor will submit a written request to County that includes supporting documents justifying requested increases at least ninety (90) days prior to the desired implementation date. Contractor will provide evidence, cite sources, demonstrate specific conditions and document how those conditions affect the cost of its performance, and identify specific efforts Contractor has taken to control and reduce those and other costs to avoid the need to increase prices. County will review proposed pricing and determine if it is allowable, fair and reasonable, and in the best interest of County to accept the proposal. County reserves the right to continue, accept or reject the price proposal, or terminate and re-solicit the contract.

Quantities referred to are estimated quantities. County reserves the right to increase or decrease the quantities and amounts. No guarantee is made regarding actual orders issued for items or quantities during the term of the agreement. County is not responsible for Contractor inventory or order commitment.

Unit prices offered must include all incidentals and associated costs required to comply with and satisfy all requirements referred to or included in this solicitation, which includes the *Instructions to Bidders, Standard Terms and Conditions* and Offer Agreement. No payments will be made for items not included in the contract.

Contractor will provide detailed documentation in support of payment requests which will document, be consistent with and not exceed County's order. Contractor will bill County within one (1) month after the date on which Contractor's right to payment accrues ("Payment Accrual Date"), which, unless this contract specifically provides otherwise, is the date goods are delivered, services are performed, or costs are incurred. Invoices must assign each amount billed to an appropriate line item of County's order and document each Payment Accrual Date. County may refuse to pay any amount

billed in an untimely manner or which is not conforming to County's order. County will refuse to pay any amount billed more than six (6) months after the Payment Accrual Date, pursuant to A.R.S. § 11-622(C).

#### **8. DELIVERY:**

Delivery will be made in accordance with the Instructions to Bidders, Standard Terms and Conditions and to the location(s) referenced on the Purchase Order.

Successful respondent shall be fully responsible for the transport of the equipment from and to Pima County Fleet Services Department at 1291 S. Mission Rd, Tucson, Arizona 85713, for installation, for the correction of items or workmanship not in compliance with the specifications, and for the return of any removed items or other property rightfully belonging to Pima County.

All deliveries shall be made Monday through Friday from 8:00 A.M. to 2:00 P.M. Successful respondent shall be required to give Mr. Bob Charlton, Pima County Fleet Services Department at 1291 S. Mission Road, Tucson, AZ 85713, or his authorized representative of the Fleet Services Department a minimum of twenty-four (24) hour notification prior to delivery with the anticipated time of delivery. Successful respondent shall provide a short familiarization and operating characteristics presentation upon delivery of equipment.

#### **9. TAXES, FEES, EXPENSES:**

Articles sold to County are exempt from federal excise taxes. County is subject to State and City sales tax. County will pay no separate charges for delivery, drayage, express, parcel post, packing, insurance, license fees, permits, costs of bonds, surcharges, or bid preparation unless expressly included in the contract and itemized by the solicitation documents.

#### **10. OTHER DOCUMENTS**

Contractor and County in entering into this contract have relied upon information provided or referenced by Pima County Solicitation No. 229988 including the Invitation For Bids, Instructions to Bidders, Standard Terms and Conditions, Solicitation Addenda, Contractor's Bid Offer, documents submitted by Contractor or References to satisfy Minimum Qualifications and on other information and documents submitted by Contractor's response to County's Solicitation. These documents are hereby incorporated into and made a part of this Contract as if set forth in full herein, to the extent not inconsistent with the provisions of this contract.

#### **11. INSURANCE:**

The Insurance Requirements herein are minimum requirements for this Contract and in no way limit the indemnity covenants contained in this Contract. Pima County in no way warrants that the minimum limits contained herein are sufficient to protect the Contractor from liabilities that arise out of the performance of the work under this Contract. The Contractor is free to purchase additional insurance.

Contractor's insurance shall be placed with companies licensed in the State of Arizona or hold approved non-admitted status on the Arizona Department of Insurance List of Qualified Unauthorized Insurers. Insurers shall have an "A.M. Best" rating of not less than A- VII. Pima County in no way warrants that the above-required minimum insurer rating is sufficient to protect the Contractor from potential insurer insolvency.

#### **Minimum Scope and Limits of Insurance:**

Contractor shall procure and maintain, until all of their obligations have been discharged, coverage with limits of liability not less than those stated below.

**Commercial General Liability (CGL)** – Occurrence Form with limits of \$1,000,000 Each Occurrence and \$2,000,000 General Aggregate. Policy shall include bodily injury, property damage, and broad form contractual liability coverage, and products – completed operations.

**Business Automobile Liability** – Bodily Injury and Property Damage for any owned, hired, and/or non-owned automobiles used in the performance of this Contract with a Combined Single Limit (CSL) of \$1,000,000.

**Workers' Compensation and Employers' Liability** - Statutory requirements and benefits. Coverage is compulsory for employers of one or more employees. Employer's Liability - \$500,000.

Note: The Workers' Compensation requirement shall not apply to a Contractor that is exempt under A.R.S. § 23-901, and when such Contractor executes the appropriate Pima County Sole Proprietor or Independent Contractor Waiver form.

**Cargo/Inland Marine Insurance** -- In an amount sufficient to cover the replacement cost of the vehicles, parts and equipment while in transit and until accepted by the County. Contractor is responsible for the payment of all deductibles under the Inland Marine policy.

**Additional Insurance Requirements:**

The policies shall include, or be endorsed to include, as required by this written agreement, the following provisions:

**Additional Insured Endorsement:** The General Liability and Business Automobile Liability Policies shall each be endorsed to include Pima County, its departments, districts, boards, commissions, officers, officials, agents, and employees as additional insured's with respect to liability arising out of the activities performed by or on behalf of the Contractor.

**Subrogation Endorsement:** The General Liability, Business Automobile Liability and Workers' Compensation Policies shall each contain a waiver of subrogation endorsement in favor of Pima County, and its departments, districts, boards, commissions, officers, officials, agents, and employees for losses arising from work performed by or on behalf of the Contractor.

**Primary Insurance Endorsement:** The Contractor's policies shall stipulate that the insurance afforded the Contractor shall be primary for this written agreement and that any insurance carried by Pima County, its agents, officials, employees or Pima County shall be excess and not contributory insurance. Insurance provided by the Contractor shall not limit the Contractor's liability assumed under the indemnification provisions of this Contract.

**Verification of Coverage:**

Contractor shall furnish Pima County with certificates of insurance (valid ACORD form or equivalent approved by Pima County) as required by this Contract. An authorized representative of the insurer shall sign the certificates.

All certificates and endorsements, as required by this written agreement, are to be received and approved by Pima County before work commences. Each insurance policy required by this Contract must be in effect at, or prior to, commencement of work under this Contract. Failure to maintain the insurance coverage or policies as required by this Contract, or to provide evidence of renewal, is a material breach of contract.

All certificates required by this Contract shall be sent directly to the appropriate County Department. The Certificate of Insurance shall include the Pima County project or contract number and project description on the certificate. Pima County reserves the right to require complete copies of all insurance policies required by this Contract at any time.

**Notice of Cancellation:**

For each insurance policy required by the insurance provisions of this contract, Contractor's insurance shall not be permitted to expire, be suspended, be canceled, or be materially changed for any reason without thirty (30) days prior written notice to Pima County. Such notice shall be mailed, emailed, hand-delivered or sent by facsimile transmission to the Pima County Contracting Representative. Notice shall include the Pima County project or contract number and project description.

**Approval and Modifications:**

Pima County Risk Management reserves the right to review or make modifications to the insurance limits, required coverage, or endorsements throughout the life of this contract, as deemed necessary. Such action will not require a formal Contract amendment but may be made by administrative action.

**12. PERFORMANCE BOND: NONE**

**13. ACKNOWLEDGEMENT of SOLICITATION ADDENDA:**

Contractor acknowledges that the following solicitation addenda have been incorporated in its offer and this contract:

Addendum #	Date	Addendum #	Date	Addendum #	Date
1	9/13/16				

**14. SMALL BUSINESS ENTERPRISE (SBE) CERTIFICATION:**

Is your firm SBE certified as defined by the solicitation's 'Instruction To Bidders'? Yes  No  (Select one)  
If 'Yes', have you included your certification document? Yes  No  (Select one) NOTE: If the SBE Certification document is not submitted with your bid the SBE Preference cannot be applied.

15. BID/OFFER CERTIFICATION:

CONTRACTOR LEGAL NAME: Freightliner of Arizona, LLC.

BUSINESS ALSO KNOWN AS: \_\_\_\_\_

MAILING ADDRESS: 9899 West Roosevelt Street

CITY/STATE/ZIP: Tolleson, AZ 85353

REMIT TO ADDRESS: 9899 West Roosevelt Street

CITY/STATE/ZIP: Tolleson, AZ 85353

CONTACT PERSON NAME/TITLE: Cory Thompson-New Truck Sales

PHONE: 623-907-9900 FAX: 623-907-6401

CONTACT PERSON EMAIL ADDRESS: cthompson@fswaz.com

EMAIL ADDRESS TO WHICH ORDERS & CONTRACTS SHALL BE TRANSMITTED:  
cthompson@fswaz.com

CORPORATE HEADQUARTERS LOCATION:  
STREET ADDRESS CITY, STATE, ZIP: 9899 West Roosevelt Street, Tolleson, AZ 85353

By signing and submitting these Offer Agreement documents, the undersigned certifies that they are legally authorized to represent and bind Contractor to legal agreements, that all information submitted is accurate and complete, that Contractor has reviewed the Pima County Procurement website for solicitation addenda and has incorporated all such addenda to its offer, that Contractor is qualified and willing to provide the items requested, and that Contractor will comply with all requirements of the solicitation. The Unit Pricing includes all costs incidental to the provision of the items in compliance with the above documents; no additional payment will be made. Conditional offers that modify the solicitation requirements may be deemed not 'responsive' and may not be evaluated. Contractor's submission of a signed offer agreement shall constitute a firm offer and upon the issuance of a Purchase Order (PO) document signed by the Pima County Procurement Director or authorized designate a binding contract is formed that will require Contractor to provide the services and materials described in this solicitation. The undersigned hereby offers to furnish the material or service in compliance with all terms, conditions, specifications, defined or referenced by the solicitation, which includes Pima County Standard Terms & Conditions, this Offer Agreement and other documents listed in this Offer Agreement's Other Documents article.

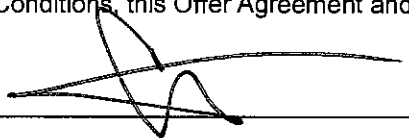
SIGNATURE:  DATE: 9/16/16

Cory Thompson-New Truck Sales  
PRINTED NAME & TITLE OF AUTHORIZED CONTRACTOR REPRESENTATIVE EXECUTING OFFER

PHONE AND E-MAIL: 623-907-9900 cthompson@fswaz.com

**PIMA COUNTY STANDARD TERMS AND CONDITIONS (06/01/16)****1. OPENING:**

Responses will be publicly opened and each respondent's name, and if a Bid the amount, will be read on the date and at the location defined in the *Invitation for Bid (IFB)* or *Request For Proposals (RFP)*. Proposals shall be opened so as to avoid disclosure of the contents of any proposal to competing offerors during the process of negotiation. All interested parties are invited to attend.

**2. EVALUATION:**

Responses shall be evaluated to determine which are most advantageous to Pima County (County) considering evaluation criteria, conformity to the specifications and other factors.

If an award is made, County will enter into an agreement with the one or multiple respondent(s) that submitted the lowest responsive bid(s) that were determined responsible for supplying the required goods or services. Unless otherwise specified on the Bid/Offer document determination of the low/lowest bids will be made considering the total bid amount.

County, at its sole discretion, reserves the following rights: 1) to waive informalities in the bid or bid procedure; 2) to reject the response of any persons or corporations that have previously defaulted on any contract with County or who have engaged in conduct that constitutes a cause for debarment or suspension as set forth in County Code section 11.32; 3) to reject any and all responses; 4) to re-advertise for bids previously rejected; 5) to otherwise provide for the purchase of such equipment, supplies materials and services as may be required herein; 6) to award on the basis of price and other factors, including but not limited to such factors as delivery time, quality, uniformity of product, suitability for the intended task, and bidder's ability to supply; 7) to increase or decrease the item quantity or eliminate any item of this solicitation prior to the award. Pricing evaluations will be based on pre-tax pricing offered by Contractor.

**3. AWARD NOTICE:**

A *Notice of Recommendation for Award* for IFB or RFP will be posted on the Procurement website and available for review by interested parties. A tabulation of responses will be maintained at the Procurement Department.

**4. AWARD:**

Awards will be made by either the Procurement Director or the Board of Supervisors in accordance with the County Procurement Code. County reserves the right to reject any or all offers, bids or proposals or to waive irregularities and informalities if it is deemed in the best interest of County. Unless expressly agreed otherwise, resulting contracts are not exclusive, are for the sole convenience of County, and County reserves the right to obtain like goods or services from other sources.

**5. WAIVER:**

Each offeror, by submission of an offer, bid or proposal waives any and all claims for damages against County or its officers or employees when County exercises any of its reserved rights.

**6. ACKNOWLEDGEMENT AND ACCEPTANCE:**

If Contractor's terms of sale are inconsistent with the terms of the resultant contract, the terms herein shall govern, unless County accepts Contractor's terms in writing. No oral agreement or understanding shall in any way modify this contract or the terms and conditions herein. Contractor's acceptance, delivery or performance called for herein shall constitute unqualified acceptance of the terms and conditions of the resultant contract.

**7. INTERPRETATION and APPLICABLE LAW:**

The contract will be interpreted, construed and given effect in all respects according to the laws of the State of Arizona. If any of Contractors' terms or conditions is not in agreement with County's terms and conditions as set forth herein, County's shall govern. This contract incorporates the complete agreement of the parties with respect to the subject matter of this contract. No oral agreement or other understanding will in any way modify the terms and conditions of this contract.

**8. WARRANTY:**

Contractor warrants goods or services to be satisfactory and free from defects.

**9. QUANTITY:**

Contractor will not exceed or reduce the quantity of goods ordered without written permission from County in the form of a properly executed Master Agreement (MA), Purchase Order (PO) Delivery Order (DO) or Delivery Order Maximo (DOM) revision or amendment as required by County Procurement Code. All quantities are estimates and County provides no guarantee regarding actual usage.

**10. PACKING:**

Contractor will make no extra charges for packaging or packing material. Contractor is responsible for safe packaging conforming to carrier's requirements.

**11. DELIVERY:**

On-time delivery of goods and services is an essential part of the consideration to be received by County. A guaranteed delivery date, or interval period from order release date to delivery, must be given if requested by the Price offer document. Upon receipt of notification of delivery delay, County at its sole option and at no cost to County may cancel the order or extend delivery times. Such extension of delivery times will not be valid unless extended in writing by an authorized representative of County.

To mitigate or prevent damages caused by delayed delivery, County may require Contractor to deliver additional quantity utilizing express modes of transport, and or overtime, all costs to be Contractor's responsibility. County reserves the right to cancel any delinquent order, procure from alternate source, or refuse receipt of or return delayed deliveries, at no cost to County. County reserves the right to cancel any order or refuse delivery upon default by Contractor concerning time, cost, or manner of delivery.

Contractor will not be held responsible for unforeseen delays caused by fires, strikes, acts of God, or other causes beyond Contractor's control, provided that Contractor provides County immediate notice of delay.

**12. SPECIFICATION CHANGES:**

County has the right to make changes in the specifications, services, or terms and conditions of an order. If such changes cause an increase or decrease in the amount due under an order or in time required for performance, an acceptable adjustment will be made and the order modified in writing. Any agreement for adjustment must be made in writing.

Nothing in this clause reduces Contractor's responsibility to proceed without delay in the delivery or performance of an order.

**13. INSPECTION:**

All goods and services are subject to inspection and testing at place of manufacture, destination or both by County. Goods failing to meet specifications of the order or contract will be held at Contractor's risk and may be returned to Contractor with costs for transportation, unpacking, inspection, repacking, reshipping, restocking or other like expenses to be the responsibility of Contractor. In lieu of return of nonconforming supplies, County, at its sole discretion and without prejudice to County's rights, may waive any nonconformity, receive the delivery, and treat the defect(s) as a warranty item, but waiver of any condition will not be considered a waiver of that condition for subsequent shipments or deliveries.

**14. SHIPPING TERMS:**

Unless stated otherwise by the contract, delivery terms are to be F.O.B. Destination & Freight Prepaid Not Billed ("F.O.B. Destination") and are to be included in the Unit Price offered by Contractor and accepted by County.

**15. PAYMENT TERMS:**

Payment terms are net thirty (30) days, unless otherwise specified by the contract.

**16. ACCEPTANCE OF MATERIALS AND SERVICES:**

County will not execute an acceptance or authorize payment for any service, equipment or component prior to delivery and verification that all specification requirements have been met.

**17. RIGHTS AND REMEDIES OF COUNTY FOR DEFAULT:**

In the event any item furnished by Contractor in the performance of the contract should fail to conform to the specifications thereof, or to the sample submitted by Contractor, County may reject same, and it thereupon becomes the duty of Contractor to reclaim and remove the same, without expense to County, and immediately replace all such rejected items with others conforming to the specifications or samples. Should Contractor fail, neglect, or refuse immediately to do so, County has the right to purchase in the open market, in lieu thereof, a corresponding quantity of any such items and to deduct from any monies due or that may become due to Contractor the difference between the price named in the Master Agreement or Purchase Order and actual cost to County.

In the event Contractor fails to make prompt delivery as specified of any item, the same conditions as to the rights of County to purchase in the open market and invoke the reimbursement condition above apply, except when delivery is delayed by fire, strike, freight embargo, or acts of god or of the government. In the event of cancellation of the Master Agreement, Purchase Order or associated orders, either in whole or in part, by reason of the default or breach by

Contractor, Contractor will bear and pay for any loss or damage sustained by County in procuring any items which the Contractor agreed to supply. The rights and remedies of County provided above are not exclusive and are in addition to any other rights and remedies provided by law or under the contract.

**18. FRAUD AND COLLUSION:**

Each Contractor, by submission of a bid, certifies that no officer or employee of County or of any subdivision thereof: 1) has aided or assisted Contractor in securing or attempting to secure a contract to furnish labor, materials or supplies at a higher price than that proposed by any other Contractor; 2) has favored one Contractor over another by giving or withholding information or by willfully misleading the bidder in regard to the character of the material or supplies called for or the conditions under which the proposed work is to be done; 3) will knowingly accept materials or supplies of a quality inferior to those called for by any contract; 4) has any direct or indirect financial interest in the offer or resulting contract. Additionally, during the conduct of business with County, Contractor will not knowingly certify, or induce others to certify, to a greater amount of labor performed than has been actually performed, or to the receipt of a greater amount or different kind of material or supplies that has been actually received. If at any time it shall be found that Contractor has in presenting any offer(s) colluded with any other party or parties for the purpose of preventing any other offer being made, then any contract so awarded shall be terminated and that person or entity shall be liable for all damages sustained by County.

**19. COOPERATIVE USE OF RESULTING CONTRACT:**

As allowed by law, County has entered into cooperative procurement agreements that enable other Public Agencies to utilize procurement agreements developed by County. Contractor may be contacted by participating agencies and requested to provide services and products pursuant to the pricing, terms and conditions defined by the County Master Agreement, or Purchase Order. Minor adjustments are allowed subject to agreement by both Contractor and Requesting Party to accommodate additional cost or other factors not present in the County's agreement and required to satisfy particular Public Agency code or functional requirements and are within the intended scope of the solicitation and resulting contract. Any such usage shall be in accordance with State, County and other Public Agency procurement rules, regulations and requirements and shall be transacted between the requesting party and Contractor. Contractor shall hold harmless County, its officers, employees, and agents from and against all liability, including without limitation payment and performance associated with such use. A list of agencies that are authorized to use County contracts can be viewed at the Procurement Department Internet home page: <http://www.pima.gov/procure> by selecting the link titled *Authorized Use of Pima County Contracts*.

**20. PATENT INDEMNITY:**

Contractor will indemnify, defend and hold County, its officers, agents and employees, harmless from liability of any nature or kind, including costs and expenses, for infringement or use of any copyrighted composition, secret process, patented or unpatented invention, article or appliance furnished or used in connection with the Master Agreement, Purchase Order, and associated orders. Contractor may be required to furnish a bond or other indemnification to County against any and all loss, damage, costs, expenses, claims and liability for patent or copyright infringement.

**21. INDEMNIFICATION:**

To the fullest extent permitted by law, Contractor shall defend, indemnify, and hold harmless Pima County, and its departments, districts, officials, and employees (hereinafter referred to as "Indemnitee") from and against any and all claims, actions, liabilities, costs, losses, or expenses, (including reasonable attorney's fees), (hereinafter collectively referred to as "Claims") arising out of actual or alleged bodily injury or personal injury of any person (including death) or loss or damage to tangible or intangible property caused, or alleged to be caused, in whole or in part, by the negligent or willful acts or omissions of Contractor or any of Contractor's directors, officers, agents, employees, volunteers or subcontractors. This indemnity includes any claim or amount arising or recovered under the Workers' Compensation Law or arising out of the failure of Contractor to conform to any federal, state or local law, statute, ordinance, rule, regulation or court decree. It is the specific intention of the parties that the Indemnitee shall, in all instances, except for Claims arising solely from the negligent or willful acts or omissions of the Indemnitee, be indemnified by Contractor from and against any and all Claims. It is agreed that Contractor will be responsible for primary loss investigation, defense and judgment costs where this indemnification is applicable. This indemnification will survive the termination of the above listed contract with the Contractor.

**22. UNFAIR COMPETITION AND OTHER LAWS:**

Responses must be in accordance with Arizona trade and commerce laws (Title 44 A.R.S.) and all other applicable County, State, and Federal laws and regulations.

**23. COMPLIANCE WITH LAWS:**

Contractor will comply with all federal, state, and local laws, rules, regulations, standards and Executive Orders, without limitation. In the event any services provided under this contract require a license issued by the Arizona Registrar of Contractors (ROC), Contractor certifies that those services will be provided by a contractor licensed by ROC to perform those services in Arizona. The laws and regulations of the State of Arizona govern the rights, performance and disputes of and between the parties. Any action relating to this Contract must be brought in a court of the State of Arizona in Pima County. Any changes in the governing laws, rules, and regulations during an agreement apply, but do not require an amendment or revisions.



**24. ASSIGNMENT:**

Contractor may not assign its rights to the contract, in whole or in part, without prior written approval of County. County may withhold approval at its sole discretion, provided that County will not unreasonably withhold such approval.

**25. CONFLICT OF INTEREST:**

This contract is subject to the provisions of A.R.S. § 38-511, the pertinent provisions of which are incorporated into and made part of all County Master Agreements or Purchase Orders as if set forth in full therein.

**26. NON-DISCRIMINATION:**

Contractor agrees to comply with all provisions and requirements of Arizona Executive Order 2009-09 which is hereby incorporated into this contract as if set forth in full herein including flow down of all provisions and requirements to any subcontractors. During the performance of this contract, Contractor must not discriminate against any employee, client or any other individual in any way because of that person's age, race, creed, color, religion, sex, disability or national origin.

**27. NON-APPROPRIATION OF FUNDS:**

County may cancel this contract pursuant to A.R.S. § 11-251(42) if for any reason the County Board of Supervisors does not appropriate funds for the stated purpose of maintaining the contract. In the event of such cancellation, County has no further obligation, other than payment for services or goods that County has already received.

**28. PUBLIC INFORMATION:**

Pursuant to A.R.S. § 39-121 et seq., and A.R.S. § 34-603(H) in the case of construction or Architectural and Engineering services procured under A.R.S. Title 34, Chapter 6, all information submitted in response to this solicitation, including, but not limited to, pricing, product specifications, work plans, and any supporting data becomes public information and upon request, is subject to release or review by the general public including competitors.

Any records submitted in response to this solicitation that Contractor reasonably believes constitute proprietary, trade secret or otherwise confidential information must be appropriately and prominently marked as CONFIDENTIAL by Contractor prior to the close of the solicitation.

Notwithstanding the above provisions, in the event records marked CONFIDENTIAL are requested for public release pursuant to A.R.S. § 39-121 et seq., County will release records marked CONFIDENTIAL ten (10) business days after the date of notice to Contractor of the request for release, unless Contractor has, within the ten (10) day period, secured a protective order, injunctive relief or other appropriate order from a court of competent jurisdiction, enjoining the release of the records. For the purposes of this paragraph, the day of the request for release is not counted in the time calculation. Contractor will be notified of any request for such release on the same day of the request for public release or as soon thereafter as practicable.

County will not, under any circumstances, be responsible for securing a protective order or other relief enjoining the release of records marked CONFIDENTIAL, nor is County in any way financially responsible for any costs associated with securing such an order.

**29. CUSTOM TOOLING, DOCUMENTATION AND TRANSITIONAL SUPPORT:**

Costs to develop all tooling and documentation, such as and not limited to dies, molds, jigs, fixtures, artwork, film, patterns, digital files, work instructions, drawings, etc. necessary to provide the contracted services or products and unique to the services or products supplied to County are included in the agreed upon Unit Price unless specifically stated otherwise in the contract. Such tools and documentation are the property of County and will be marked, as is practical, as the "Property of Pima County" and if requested by County a copy of the tooling and documentation will be delivered to County within twenty (20) days of acceptance by County of the first article sample, or not later than ten (10) days of termination of the contract associated with their development, without additional cost to County. Contractor also agrees to act in good faith to facilitate the transition of work to a subsequent Contractor if and as reasonably requested by County at no additional cost. Should exceptional circumstances be present that may justify an additional charge, Contractor may submit said justification and proposed cost and negotiate an agreement acceptable to both Contractor and County, but Contractor may not withhold any requested tooling, document or support as defined above that would delay the orderly, efficient and prompt transition of work. Should conduct by Contractor result in additional costs to County, Contractor will reimburse County for said actual and incremental costs provided that County had given Contractor reasonable time to respond to County's requests for support.

**30. AMERICANS WITH DISABILITIES ACT:**

Contractor will comply with all applicable provisions of the Americans with Disabilities Act (public law 101-336, 42 USC 12101-12213) and all applicable federal regulations under the act, including 28 CFR parts 35 and 36.

**31. NON-EXCLUSIVE:**

Contracts resulting from this solicitation are non-exclusive and are for the sole convenience of County, which reserves the right to obtain like goods and services from other sources for any reason.

**32. PROTESTS:**

An interested party may file a protest regarding any aspect of a solicitation, evaluation, or recommendation for award. Protests must be filed in accordance with the Pima County Procurement Code, Section 11.20.010.

**33. TERMINATION:**

County reserves the right to terminate any Master Agreement, Purchase Order, Delivery Order, Delivery Order Maximo or award, in whole or in part, at any time, without penalty or recourse, when in the best interests of County. Upon receipt of written notice, Contractor will immediately cease all work as directed by the notice, notify all subcontractors of the effective date of termination and take appropriate actions to minimize further costs to County. In the event of termination under this paragraph, all documents, data, and reports prepared by Contractor under the contract become the property of and must be promptly delivered to County. Contractor is entitled to receive just and equitable compensation for work in progress, work completed and materials accepted before the effective date of the termination. The cost principles and procedures defined by A.A.C. R2-7-701 apply.

**34. ORDER OF PRECEDENCE-CONFLICTING DOCUMENTS:**

In the event of inconsistencies between contract documents, the following is the order of precedence, superior to subordinate, that will apply to resolve the inconsistency: Master Agreement, Delivery Order or Delivery Order Maximo, Purchase Order, offer agreement or contract attached to a Master Agreement, Purchase Order, Delivery Order or Delivery Order Maximo; these standard terms and conditions; any other solicitation documents.

**35. INDEPENDENT CONTRACTOR:**

The status of Contractor is that of an independent Contractor. Contractor and Contractor officer's agents or employees are not considered employees of County and are not entitled to receive any employment-related fringe benefits under the County Merit System. Contractor is responsible for payment of all federal, state and local taxes associated with the compensation received pursuant to this Contract and will indemnify and hold County harmless from any and all liability which County may incur because of Contractor's failure to pay such taxes. Contractor is solely responsible for its program development and operation.

**36. BOOKS AND RECORDS:**

Contractor will keep and maintain proper and complete books, records and accounts, which will be open at all reasonable times for inspection and audit by duly authorized representatives of County. In addition, Contractor will retain all records relating to this contract at least five (5) years after its termination or cancellation or, if later, until any related pending proceeding or litigation has been closed.

**37. COUNTERPARTS:**

The Master Agreement or Purchase Order awarded pursuant to this solicitation may be executed in any number of counterparts and each counterpart is considered an original, and together such counterparts constitute one and the same instrument. For the purposes of the Master Agreement and Purchase Order, the signed offer of Contractor and the signed acceptance of County are each considered an original and together constitute a binding Master Agreement, if all other requirements for execution have been met.

**38. AUTHORITY TO CONTRACT:**

Contractor warrants its right and power to enter into the Master Agreement or Purchase Order. If any court or administrative agency determines that County does not have authority to enter into the Master Agreement or Purchase Order, County is not liable to Contractor or any third party by reason of such determination or by reason of the Master Agreement or Purchase order.

**39. FULL AND COMPLETE PERFORMANCE:**

The failure of either party to insist on one or more instances upon the full and complete performance with any of the terms or conditions of the Master Agreement, Purchase Order, Delivery Order or Delivery Order Maximo to be performed on the part of the other, or to take any action permitted as a result thereof, is not a waiver or relinquishment of the right to insist upon full and complete performance of the same, or any other covenant or condition, either in the past or in the future. The acceptance by either party of sums less than may be due and owing it at any time is not an accord and satisfaction.

**40. SUBCONTRACTORS:**

Contractor is fully responsible for all acts and omissions of any subcontractor and of persons directly or indirectly employed by any subcontractor, and of persons for whose acts Contractor may be liable to the same extent that Contractor is responsible for the acts and omissions of persons directly employed by it. Nothing in this contract creates any obligation on the part of County to pay or see to the payment of any money due any subcontractor, except as may be required by law.

**41. SEVERABILITY:**

Each provision of this Contract stands alone, and any provision of this Contract found to be prohibited by law is ineffective to the extent of such prohibition without invalidating the remainder of this Contract.

**42. LEGAL ARIZONA WORKERS ACT COMPLIANCE:**

Contractor hereby warrants that it will at all times during the term of this Contract comply with all federal immigration laws applicable to Contractor's employment of its employees, and with the requirements of A.R.S. § 23-214 (A) (together the "State and Federal Immigration Laws"). Contractor will further ensure that each subcontractor who performs any work for Contractor under this contract likewise complies with the State and Federal Immigration Laws.

County has the right at any time to inspect the books and records of Contractor and any subcontractor in order to verify such party's compliance with the State and Federal Immigration Laws.

Any breach of Contractor's or any subcontractor's warranty of compliance with the State and Federal Immigration Laws, or of any other provision of this section, is a material breach of this Contract subjecting Contractor to penalties up to and including suspension or termination of this Contract. If the breach is by a subcontractor, and the subcontract is suspended or terminated as a result, Contractor will take such steps as may be necessary to either self-perform the services that would have been provided under the subcontract or retain a replacement subcontractor as soon as possible so as not to delay project completion.

Contractor will advise each subcontractor of County's rights, and the subcontractor's obligations, under this Article by including a provision in each subcontract substantially in the following form:

"Subcontractor hereby warrants that it will at all times during the term of this contract comply with all federal immigration laws applicable to Subcontractor's employees, and with the requirements of A.R.S. § 23-214 (A). Subcontractor further agrees that County may inspect the Subcontractor's books and records to insure that Subcontractor is in compliance with these requirements. Any breach of this paragraph by Subcontractor is a material breach of this contract subjecting Subcontractor to penalties up to and including suspension or termination of this contract."

Any additional costs attributable directly or indirectly to remedial action under this Article is the responsibility of Contractor. In the event that remedial action under this Article results in delay to one or more tasks on the critical path of Contractor's approved construction or critical milestones schedule, such period of delay will be excusable delay for which Contractor is entitled to an extension of time, but not costs.

**43. CONTROL OF DATA PROVIDED BY COUNTY:**

For those projects and contracts where County has provided data to enable the Contractor to provide contracted services or products, unless otherwise specified and agreed to in writing by County, Contractor will treat, control and limit access to said information as confidential and will under no circumstances release any data provided by County during the term of this contract and thereafter, including but not limited to personal identifying information as defined by A.R.S. § 44-1373, and Contractor is further prohibited from selling such data directly or through a third party. Upon termination or completion of the contract, Contractor will either return all such data to County or will destroy such data and confirm destruction in writing in a timely manner not to exceed sixty (60) calendar days.

**44. ISRAEL BOYCOTT CERTIFICATION:**

Contractor hereby certifies that it is not currently engaged in, and will not for the duration of this Contract engage in, a boycott of Israel as defined by A.R.S. § 35-393.01. Violation of this certification by Contractor may result in action by the County up to and including termination of this Contract.

**END OF PIMA COUNTY STANDARD TERMS AND CONDITIONS**

**ATTACHMENT A – DETAILED SPECIFICATIONS**

**MINIMUM REQUIREMENTS (MUST BE MET):**

**Contractor Name:** Freightliner of Arizona

ITEM #	DESCRIPTION	MARK AN "X" YES
1	Truck shall meet all the latest revised Federal Emission Standards, OSHA and Federal Safety Standards, and Arizona Department of Transportation regulations.	X
2	Truck offered shall be manufactured and/or assembled in the United States.	X
3	Original manufacturer's serial numbers are not altered in any way.	X
4	Truck is manufacturer's current model of production at time of delivery.	X
5	Truck shall be new and unused. (Demonstrator models shall not be acceptable).	X
6	Successful respondent shall have final built truck inspected and approved for use by the Arizona Motor Vehicle Division. Approved inspection slip shall be delivered simultaneous with truck delivery.	X

**GENERAL SPECIFICATION REQUIREMENTS:**

1. Successful respondent shall maintain a local factory authorized maintenance facility within the Tucson metropolitan area (service hours shall be from 8:00 A.M. to 5:00 P.M., Monday through Friday) or have specific agreements in force with a third party to provide local maintenance. If applicable a document showing evidence of the third party agreement to provide necessary maintenance support shall be submitted with the bid.
2. The warranty period shall be as a minimum, one (1) year unlimited miles and hours for both parts and labor. Warranty repair and/or replacement will be performed at no additional charge to Pima County. During the one year warranty period, towing the equipment to and from the repair facility will not be an additional charge to Pima County
3. The successful respondent shall be responsible for all repairs needed within the warranty period. Respondent shall determine if the repairs required are to be accomplished by the body builder or the manufacturer, (cab & chassis). The successful bidder will then be responsible for delivering the truck and/or the equipment to the proper warranty facility for repairs. After proper repairs are complete, vehicle shall be returned to the Fleet Services Department. Please refer to Attachment C for the Certification of stocking, supplying of parts and service program.
4. The successful Contractor is to provide towing, anywhere within Pima County, at no charge to Pima County for warranty related breakdown/repairs to their facility or to the appropriate warranty dealer. Once the Contractor is notified of a breakdown, the unit must be picked up within four (4) hours.
5. Respondent shall submit with the bid response a comprehensive list with their bid detailing each of the specifications of the proposed vehicle that separately address each of the specifications as set forth in this bid.
6. Brochures on the proposed truck/equipment shall be submitted with bid giving complete specifications and other general data and equipment.
7. Warranty brochures shall be submitted with bid explaining the warranty coverage and defining specifically what is covered by the warranty.
8. Contractor has submitted with this bid a comprehensive list with their bid detailing each of the specifications of the proposed vehicle that address each of the specifications as set forth in this bid.

**ATTACHMENT A – DETAILED SPECIFICATIONS** (continued)

The following documents shall be provided to Pima County upon delivery of each truck:

1. **Manufacturer Statement of Origin (M.S.O.), which must include the odometer statement. Unless otherwise ordered in writing, the M.S.O. shall show the owner/purchaser of the equipment as:**  
**Pima County Board of Supervisors**  
**1291 S. Mission Road**  
**Tucson, AZ 85713**
2. Warranty Document.
3. Manufacturers unaltered invoice
4. Attachment "B"- Pre-Delivery Checklist fully completed for each unit to ensure that the vehicle is in compliance with the specifications submitted with bid response.
5. Delivery ticket specifying the purchase order number, and the serial number of the truck
6. Arizona Motor Vehicle Inspection slip showing the vehicle has passed inspection
7. Successful respondent receiving award shall provide for both **vehicles and equipment two (2) CD's** or Thumb drives providing Pima County with the following **(a-g)**:
  - a. Maintenance-Overhaul (shop) manuals
  - b. Operator's manuals
  - c. Wiring Diagrams
  - d. Service Manuals
  - e. Manuals for auxiliary equipment
  - f. Successful bidder may also provide a web site to enable Pima County to acquire information directly as long as there is no subscription to join or a fee to pay to get this information.
  - g. Four (4) sets of keys
8. Bidder shall submit with bid response a chart detailing weight on axles with full load to include net legal payload capacity.

**END OF ATTACHMENT A: DETAILED SPECIFICATIONS**

**ATTACHMENT B – SPECIFICATION****CHECK-LIST FOR****Group 1 – Two (2) New 12 Yard Semi-Elliptical Dump Truck****BIDDERS SHALL FILL IN THE FOLLOWING:**

		<b><u>YES</u></b>	<b><u>NO</u></b>
<b>WHEELBASE:</b>	216" APPROXIMATE	<u>X</u>	___
	<b>WHEEL BASE LENGTH:</b> _____ 214" _____		
<b>C.A.</b>	145" APPROXIMATE	<u>X</u>	___
	<b>CA LENGTH:</b> _____ 145" _____		
<b>GVWR:</b>	58,000 LBS MINIMUM	<u>X</u>	___
<b>ENGINE:</b>	DIESEL, 440 H.P. NET MINIMUM AT RATED RPM, 12.4 LITER MINIMUM 1550 MINIMUM FT. LB. TORQUE NET AT RATED RPM WITH ELECTRONIC CONTROLS. ENGINE COMPRESSION BRAKE. ENGINE WARRANTED FOR 5 YEARS/ 150,000 MILES OR WILL WORK WITH CONTRACTOR FOR A BETTER COVERAGE. CONTRACTOR SHALL STATE WARRANTY PERIODS. ENGINE BID MUST BE AN ACCEPTABLE MATCH TO THE TRANSMISSION AS CERTIFIED BY THE TRANSMISSION MANUFACTURE. ENGINE SHALL MEET THE 2012 EMISSION STANDARDS.CONTRACTOR TO STATE ENGINE MAKE AND MODEL OF ENGINE BID.		Detroit-DD13  5 years/200,000 miles
<b>TRANSMISSION:</b>	ALLISON HD-4500 RDS WITH AIR TO OIL COOLER, OR APPROVED EQUAL, WIDE RATIO, 6-SPEED MINIMUM, WITH PTO GEAR, WITH OIL LEVEL SENSOR, NO RETARDER. RATED FOR 440 H.P. NET INPUT MINIMUM AND 1550 FT. LB. TORQUE NET INPUT MINIMUM. TRANSMISSION WARRANTED FOR 5 YEARS/250,000 MILES. CASTROL TRANSYND IS TO BE INSTALLED AT THE FACTORY.CONTRACTOR SHALL STATE WARRANTY	<u>X</u>	___  5 years/unlimited miles
<b>EXHAUST:</b>	MAXIMUM DIAMETER AVAILABLE, CONTRACTOR SHALL STATE, VERTICAL STACK WITH SHIELD, FORMED AT TOP TO PREVENT RAIN ENTERING OR EQUIPPED WITH A RAIN CAP, <b>HEIGHT FROM GROUND 10' MAXIMUM.</b> ALUMINIZED STEEL, ALUMINUM GUARD, GRAB HANDLE CAB MOUNTED RIGHT SIDE.	<u>X</u>	___
<b>AIR CLEANER:</b>	HEAVY DUTY, MAXIMUM AVAILABLE, WITH RESTRICTION INDICATOR IN CAB AND PRE-CLEANER	<u>X</u>	___
<b>OIL FILTER:</b>	MANUFACTURES STANDARD	<u>X</u>	___
<b>COOLING SYSTEM:</b>	HEAVY DUTY ROUGH SERVICE MOUNTING OR EQUAL, MAXIMUM AVAILABLE WITH KYSOR FAN DRIVE OR EQUAL WITH AUTO ON/OFF. CROSS FLOW TYPE RADIATOR WITH 950 SQUARE INCHES, MINIMUM, OF CHARGING AIR COOLER. CONTRACTOR TO SPECIFY FRONTAL AREA AND AMBIENT TEMPERATURE RATING.	<u>X</u>	___

**ATTACHMENT B – SPECIFICATION** (continued)**CHECK-LIST FOR****Group 1 – Two (2) New 12 Yard Semi-Elliptical Dump Truck**

<b><u>BIDDERS SHALL FILL IN THE FOLLOWING:</u></b>		<b><u>YES</u></b>	<b><u>NO</u></b>
<b>BUG SCREEN:</b>	RADIATOR- MOUNTED BEHIND GRILLE 1/4" GRID STEEL SCREEN. SCREEN DOOR MATERIAL WILL NOT BE ACCEPTED.	<u>X</u>	—
<b>ELECTRICAL SYSTEM:</b>	12 VOLT, 3 MAINTENANCE FREE BATTERIES, 1950 CCA, MINIMUM, OR EQUAL, ALUMINUM BATTERY BOX <b>WITH JUMP START CABILITIES EXTERNAL OF BATTERY BOX OR AT ENGINE.</b> ALTERNATOR RATED AT 130 AMP CAPACITY. STARTER 12-VOLT WITH THERMAL OVER CRANK PROTECTION. CIRCUIT BREAKERS WITH MANUAL RESET (MAIN PANEL) SAE TYPE III OR EQUAL ITH TRIP INDICATORS	<u>X</u>	—
<b>STEERING:</b>	POWER, HEAVY DUTY, FULL HYDRAULIC, (2) SHEPPARD M-90/M-80, DUAL POWER OR EQUAL	<u>X</u>	—
<b>AIR COMPRESSOR:</b>	16.0 CFM, MINIMUM, WATER COOLED, BENDIX TU-FLO 750 OR EQUAL.	<u>X</u>	—
<b>BRAKES:</b>	FULL AIR WITH WATER FILTERS/DRIERS, AUTOMATIC DRAIN VALVE, BENDIX ANTILOCK BRAKE SYSTEM OR EQUAL. COLOR CODED NYLON BRAKE LINES OR EQUAL, AIR LINES INSIDE FRAME TO MEET ALL REGULATIONS. FRONT AND REAR AUTOMATIC SLACK ADJUSTERS, FRONT BRAKES S-CAM TYPE, 16.5" BY 5.0" MINIMUM, REAR BRAKES S-CAM TYPE, 16.5" X 7.0" MINIMUM.	<u>X</u>	—
<b>PARKING BRAKE:</b>	PIGGY BACK WITH AUXILIARY TANK	<u>X</u>	—
<b>FRAME:</b>	<b>FRAME RAILS HEAT TREATED ALLOY STEEL OR EQUAL, (110,000 PSI YIELD); 10.125" X 3.502" X 0.312"; 199" THRU 228" WB WITH 92" MAXIMUM AF OR EQUAL. FRAME REINFORCEMENT OUTER "C" CHANNEL, HEAT TREATED ALLOY STEEL, (110,000 PSI YIELD); 10.813" X 3.812" X 0.312"; 199" THRU 228" WB WITH 92" MAXIMUM AF OR EQUAL. MINIMUM 2,800,000 RBM.</b>	<u>X</u>	—
<b>FRONT AXLE:</b>	I-BEAM TYPE (MERITOR (ROCKWELL) FL-941 OR EQUAL, 18,000-LB CAPACITY OR EQUAL,	<u>X</u>	—
<b>FRONT SUSPENSION:</b>	FRONT SPRINGS MULTILEAF, SHACKLE TYPE, 18,000-LB CAPACITY LESS SHOCK ABSORBERS	<u>X</u>	—

**ATTACHMENT B – SPECIFICATION** (continued)

**CHECK-LIST FOR**

**Group 1 – Two (2) New 12 Yard Semi-Elliptical Dump Truck**

**BIDDERS SHALL FILL IN THE FOLLOWING:**

		<u>YES</u>	<u>NO</u>
<b>PROPSHAFTS:</b>	1810 HEAVY DUTY MAIN WITH 1710 HD INTER-AXLE.	<u>X</u>	___
<b>REAR AXLES:</b>	TANDEM, MERITOR (ROCKWELL) RT-40-145P OR EQUAL, SINGLE REDUCTION 40,000 LB CAPACITY WITH DRIVER CONTROLLED MAIN LOCKING DIFFERENTIAL IN REAR-REAR AXLE, LUBE OIL PUMP AND 200 WHEEL ENDS OR EQUAL. VEHICLE WILL NEED TO REACH A SPEED OF 75 MPH AROUND A 4.88 GEAR RATIO. CONTRACTOR TO STATE.		4.33 GEAR RATIO
		<u>X</u>	___
<b>REAR SUSPENSION:</b>	TANDEM, (HENDRICKSON HN-402-52) OR EQUAL WALKING BEAM TYPE 52" AXLE SPACING, 40,000 LB CAPACITY, WITH RUBBER SPRINGS, WITH RUBBER END BUSHINGS, SHOCK ABSORBERS AND TRANSVERSE TORQUE RODS WITH BAR PIN TYPE BEAM END ADAPTERS OR EQUAL. CONTRACTOR TO STATE.		HN-402-52
		<u>X</u>	___
<b>WHEELS:</b>	FRONT DISC, 22.5" PAINTED STEEL, WHITE, 10-STUD HUB PILOTED, FLANGED NUT, METRIC MOUNT, 9.00 DC RIMS WITH STEEL HUBS OR EQUAL. REAR DUAL DISC, 22.5" PAINTED STEEL, WHITE, 10-STUD, HUB PILOTED, FLANGED NUT, METRIC MOUNT, 8.25 DC RIMS, WITH STEEL HUBS. REAR WHEEL SEALS (STEMCO GUARDIAN) OR EQUAL, OIL LUBRICATED WHEEL BEARINGS. FRONT WHEEL SEALS (STEMCO GUARDIAN) OR EQUAL, OIL LUBRICATED WHEEL BEARINGS.	<u>X</u>	___
<b>TIRES:</b>	FRONT, (2) 315/80R22.5 UNISTEEL G291 (GOODYEAR) OR EQUAL, LOAD RANGE L, 20 PLY. REAR, (8) 11R22.5 UNISTEEL G167A (GOODYEAR) OR EQUAL, LOAD RANGE H, 16 PLY. TRAC.	<u>X</u>	___
<b>BUMPER:</b>	HEAVY DUTY, PAINTED STEEL, SWEPT BACK OR EQUAL. TWO FRONT FRAME MOUNTED TOW HOOKS.	<u>X</u>	___
<b>CAB:</b>	CONVENTIONAL, INSULATED, WITH FIBERGLASS TILT HOOD AND FENDERS WITH GRILLE. FULL TINTED GLASS, DUAL AIR HORNS, RECTANGULAR CONVEX MIRROR MOUNTED ABOVE RIGHT DOOR FOR BLIND SPOTS NEXT TO RIGHT SIDE OF CAB, RETRACTABLE MIRRORS BOTH SIDES APPROXIMATELY 7" X 16" WITH NON-MOTORIZED MIRROR HEADS AND WITH SEPARATE 8 CONVEX SPOT MIRRORS, GRAB HANDLES EACH SIDE, TURN SIGNALS, MARKER LIGHTS, AND REFLECTORS TO MEET ALL REGULATIONS. ELECTRIC HORN UNDER HOOD, HEAVY DUTY		



WINDSHIELD WIPERS, STEPS ON EACH SIDE  
FOR ENTRANCE.

X       

**ATTACHMENT B – SPECIFICATION** (continued)

**CHECK-LIST FOR**

**Group 1 – Two (2) New 12 Yard Semi-Elliptical Dump Truck**

**BIDDERS SHALL FILL IN THE FOLLOWING:**

**YES    NO**

<b>CAB INTERIOR:</b>	DRIVER SEAT (BOSTROM 910, S/N830068177 MDL T-910) OR EQUAL, AIR SUSPENSION, INTERMEDIATE BACK, ALL OR PART CLOTH, ISOLATED, ADJUSTER, AIR LUMBAR SUPPORT, SEAT CUSHION AND SEAT BACK ANGLE ADJUSTMENT, LEFT SIDE ARM REST MOUNTED INBOARD, WITH VOCATIONAL TRIM LEVEL. PASSENGER SEAT (NATIONAL STATIC MODEL 192) OR EQUAL, NON-SUSPENSION, HIGH BACK, ALL CLOTH WITH RIGHT SIDE ARM REST, WITH VOCATIONAL TRIM LEVEL. SEAT BELTS, 3-POINT LAP AND SHOULDER BELT TYPE. HEATER AND DEFROSTER WITH FRESH AIR PROVISION, WITH PREMIUM HEATER HOSES. INTERIOR TRIM VOCATIONAL LEVEL; VINYL OR EQUAL. TWO SUNVISORS, DOME LIGHT. 17" TO 21" DIAMETER STEERING WHEEL DUSTPROOF, WATERPROOF CONTAINER TO STORE VALUABLE DOCUMENTS, TWO COAT HOOKS, ADDITIONAL POWER OUTLET FOR CELL PHONE. ADDITIONAL AIR OFF SEAT WITH 4 FOOT COILED AIR LINE WITH BLOW GUN ATTACHED.	<u>X</u> <u>   </u>
<b>FUEL TANKS:</b>	SINGLE 100 GALLON, NON-POLISHED ALUMINUM TANK MOUNTED LEFT SIDE UNDER CAB WITH DUAL FUEL DRAW. TRUCK IS DRIVEN OFF ROAD AND NEEDS MAXIMUM GROUND CLEARANCE.  <b>GROUND CLEARANCE HIEGHT:</b> <u>Laden clearance height 11.7"</u>	<u>X</u> <u>   </u>
<b>FUEL FILTERS:</b>	TWO EACH, SCREW ON, ONE AT ENGINE, ONE AT TANK WITH WATER SEPARATOR	<u>X</u> <u>   </u>
<b>RADIO:</b>	AM-FM STEREO, AMERICAN MADE, FACTORY ELECTRONIC TUNING AND CLOCK, MULTIPLE DUAL CONE SPEAKERS (2) MINIMUM. ANTENNA MOUNTED ON LEFT MIRROR OR EQUAL.	<u>X</u> <u>   </u>
<b>AIR CONDITIONING:</b>	FACTORY INSTALLED, INTERNAL CAB – NO ROOF MOUNTING	<u>X</u> <u>   </u>
<b>INSTRUMENTATION:</b>	SPEEDOMETER, ODOMETER, OIL PRESSURE GAUGE, WATER TEMPERATURE GAUGE, ENGINE HOUR METER, VOLT METER, FUEL GAUGE, TACHOMETER, DUAL AIR PRESSURE GAUGES,	<u>X</u> <u>   </u>

**ATTACHMENT B – SPECIFICATION** (continued)**CHECK-LIST FOR****Group 1 – Two (2) New 12 Yard Semi-Elliptical Dump Truck****BIDDERS SHALL FILL IN THE FOLLOWING:**

		<u>YES</u>	<u>NO</u>
<b>AUTOMATIC WARNING SYSTEM</b>	SEPARATE AUDIBLE (ABOVE AMBIENT LEVELS) ALARMS FOR LOW ENGINE OIL PRESSURE, ENGINE OVER TEMPERATURE, LOW AIR PRESSURE. SHUTDOWN SYSTEM SHALL BE ACTIVATED TO SENSE THE SLIGHTEST VARIATION OF THESE THREE SYSTEMS, IF FAILING, AND AUTOMATTICALLY SHUT THE ENGINE DOWN TO PREVENT ENGINE DAMAGE. CONTRACTOR TO STATE WHICH SYSTEMS WILL BE MONITORED BY THE AUTO SHUT/DOWN SYSTEM.		
	<b>TYPE OF SYSTEM:</b> <u>Oil Pressure, Temperature, Air Pressure</u>	<u>X</u>	—
<b>FENDERS:</b>	FEDERAL LEGAL MUDFLAPS TO COVER REAR WHEELS, ANTI-SAIL TYPE. (2) BEHIND FRONT TIRES.	<u>X</u>	—
<b>RADIO NOISE SUPPRESSION:</b>	UNIT WILL BE EQUIPPED WITH AM AND MOBILE RADIO NOISE SUPPRESSION PACKAGE. ELECTRIC AND ELECTRONIC COMPONENTS OF THE UNIT SHALL NOT INTERFERE WITH SIGNALS RECEIVED OR TRANSMITTED BY THE MOBILE RADIO SYSTEM, NOR SHALL THE ELECTRIC AND ELECTRONIC COMPONENTS OF THE UNIT BE AFFECTED BY THE OPERATION OF THE MOBILE TRANSMITTER OR RECEIVER.	<u>X</u>	—
<b>BACK-UP ALARM:</b>	ELECTRIC BACKUP ALARM, 97dB MINIMUM. WEATHERPROOF AND STEAM-CLEANABLE.	<u>X</u>	—
<b>COLOR:</b>	CAB, BODY AND WHEELS - STANDARD WHITE FRAME - STANDARD BLACK	<u>X</u>	—
<b>WEIGHT DISTRIBUTION:</b>	CONTRACTOR TO SUPPLY WITH BID CHART DETAILING WEIGHT ON AXLES WITH FULL LOAD TO INCLUDE NET LEGAL PAYLOAD CAPACITY.	<u>X</u>	—
<b>SAFETY EQUIPMENT:</b>	FIRE EXTINGUISHER (5LB ALL PURPOSE) MOUNTED IN CAB, WITHIN EASY REACH OF THE OPERATOR, SAFETY TRIANGLE KIT IN CAB, ALL LADDERS, STEPS AND WALKING AREAS SHALL BE NON-SLIP TYPE.	<u>X</u>	—

**ATTACHMENT B – SPECIFICATION (cont)****CHECK-LIST FOR****Group 1 – Two (2) New 12 Yard Semi-Elliptical Dump Truck****BIDDERS SHALL FILL IN THE FOLLOWING:****YES    NO**

<b>BODY:</b>	16 X 42 SEMI ELLIPICAL. LENGTH OF 16 FEET AND 42 INCH SIDES WITH A CAPACITY OF 12 -13 YARDS. CONSTRUCTED OF 1/4 INCH AR-400 MATERIAL, FLOOR, SIDES, AND ENDS. CROSSMEMBERLESS DESIGN 8 INCH CHANNEL LONGSILLS WITH STANDARD DOGHOUSE STYLE HOIST MOUNT AND 152 INCH STROKE WITH A 4 STAGE HOIST CYLINDER. AIR OPERATED HIGH LIFT TAILGATE. A 1/2 CAB GUARD AND A FIXED 12 INCH SPREADER APRON. DIRECT MOUNT HOT SHIFT PTO AND PUMP WITH AIR OPERATED CONTROLS. A FRAME MOUNTED HYDRAULIC TANK WITH A SIGHT GLASS AND STEEL FENDERS OVER DRIVE AXLES. CONTROL TOWER MOUNTED NEXT TO SEAT. HEAVY DUTY ANTI-SAIL MUD FLAPS. LIGHTS AND REFLECTORS TO MEET DOT SAFETY STANDARDS AND BACK-UP ALARM. BODY TO BE PREPPED AND PAINTED WITH 2 COATS OF WHITE PAINT.	COMPLY  <u>X</u> <u>    </u>
<b>HOIST:</b>	GALLION HOIST MODEL #FD73-126B, SHORT SUB FRAME TYPE OR EQUAL. FRONT MOUNTED SINGLE TELESCOPIC CYLINDER AND TOP MOUNTED HYDRAULIC OIL TANK WITH SHUT OFF VALVE AT TANK. HYDRAULIC TANK SHALL HAVE A SIGHT GLASS TO DETERMINE FLUID LEVEL. HEAVY DUTY TWO GEAR SINGLE SPEED HOT SHIFT REBUILDABLE PTO WITH OVERSPEED. DOT SAFETY BODY PROP TO HOLD UP UNLOADED BODY, BODY UP SAFETY LIGHT IN CAB. CONTROL PEDESTAL IN CAB WITH SAFETY CABLE CONTROLS FOR PUMP AND PTO 24 TON CAPACITY NTEA 100 OR EQUAL.	COMPLY  <u>X</u> <u>    </u>
<b>PUMP:</b>	HEAVY DUTY, CAST IRON REBUILDABLE, INTEGRAL PUMP AND CONTROL VALVE. APPROXIMATELY 27 GPM AND 2,000 PSI CAPACITY. HOT SHIFT CONTROL, PRESSURE LUBRICATED.	COMPLY  <u>X</u> <u>    </u>
<b>LIGHTS:</b>	LIGHTS AND REFLECTOR SHALL MEET DOT REQUIREMENTS. HEAD LIGHTS SHALL BE SEALED BEAM OR EQUAL AND TAIL-LIGHT AND BRAKE LIGHTS SHALL BE LED, BUILT INTO THE DUMP BODY NOT HANGING ON THE SUSPENSION TO COLLECT DIRT AND DEBRIS.	COMPLY  <u>X</u> <u>    </u> COMPLY
<b>PAINT:</b>	ALL MILL SCALE SHALL BE REMOVED PRIOR TO PRIMER COAT AND TWO COATS, MINIMUM, OF PURE WHITE URETHANE APPLIED OR EQUAL.	<u>X</u> <u>    </u>



**ATTACHMENT B – SPECIFICATION** (continued)**CHECK-LIST FOR****Group 2 – One (1) 4000 GALLON STAINLESS STEEL TANK WATER TRUCK****BIDDERS SHALL FILL IN THE FOLLOWING:**

		<b><u>YES</u></b>	<b><u>NO</u></b>
<b>WHEELBASE:</b>	216" APPROXIMATE	<u>X</u>	___
	<b>WHEEL BASE LENGTH:</b> _____ 214" _____		
<b>C.A.</b>	145" APPROXIMATE	<u>X</u>	___
	<b>CA LENGTH:</b> _____ 145" _____		
<b>GVWR:</b>	58,000 LBS MINIMUM	<u>X</u>	___
<b>ENGINE:</b>	DIESEL, 440 H.P. NET MINIMUM AT RATED RPM, 12.4 LITER MINIMUM, MINIMUM, 1550 MINIMUM FT. LB. TORQUE NET AT RATED RPM WITH ELECTRONIC CONTROLS. ENGINE COMPRESSION BRAKE WITH THREE PHASE SWITCH OR EQUAL. ENGINE WARRANTED FOR 5 YEARS/ 150,000 MILES *SEE ATTACHMENT C FOR SPECIFICICS. OR WILL WORK WITH CONTRACTOR FOR A BETTER COVERAGE. CONTRACTOR SHALL STATE WARRANTY PERIODS. ENGINE BID MUST BE AN ACCEPTABLE MATCH TO THE TRANSMISSION AS CERTIFIED BY THE TRANSMISSION MANUFACTURE. ENGINE SHALL MEET THE 2015 EMISSION STANDARDS. CONTRACTOR TO STATE ENGINE MAKE AND MODEL OF ENGINE BID.		Detroit-DD13 5 years/200,000 miles
		<u>X</u>	___
<b>TRANSMISSION:</b>	ALLISON HD-4500 RDS WITH AIR TO OIL COOLER, OR EQUAL, WIDE RATIO, 6-SPEED MINIMUM, WITH PTO GEAR, WITH OIL LEVEL SENSOR, NO RETARDER. RATED FOR 440 H.P. NET INPUT MINIMUM AND 1550 FT. LB. TORQUE NET INPUT MINIMUM. TRANSMISSION WARRANTED FOR 5 YEARS/250,000 MILES. CASTROL TRANSYND IS TO BE INSTALLED AT THE FACTORY. CONTRACTOR SHALL STATE WARRANTY.		5 years/unlimited miles
		<u>X</u>	___
<b>EXHAUST:</b>	MAXIMUM DIAMETER AVAILABLE, CONTRACTOR SHALL STATE, VERTICAL STACK WITH SHIELD, FORMED AT TOP TO PREVENT RAIN ENTERING OR EQUIPPED WITH A RAIN CAP, <b>HEIGHT FROM GROUND 10' MAXIMUM.</b> DPF FILTER LOCATED UNDER CAB ON THE RIGHT SIDE. PREFER ALUMINIZED STEEL, ALUMINUM GUARD, GRAB HANDLE CAB MOUNTED RIGHT SIDE.		
		<u>X</u>	___
<b>AIR CLEANER:</b>	HEAVY DUTY, MAXIMUM AVAILABLE, WITH RESTRICTION INDICATOR IN CAB AND PRE-CLEANER.		
		<u>X</u>	___
<b>OIL FILTER:</b>	MANUFACTURES STANDARD		
		<u>X</u>	___

**ATTACHMENT B – SPECIFICATION** (continued)**CHECK-LIST FOR****Group 2 – One (1) 4000 GALLON STAINLESS STEEL TANK WATER TRUCK**

<b><u>BIDDERS SHALL FILL IN THE FOLLOWING:</u></b>		<b><u>YES</u></b>	<b><u>NO</u></b>
<b>COOLING SYSTEM:</b>	HEAVY DUTY ROUGH SERVICE MOUNTING OR EQUAL, MAXIMUM AVAILABLE WITH KYSOR FAN DRIVE OR EQUAL WITH AUTO ON/OFF. CROSS FLOW TYPE RADIATOR WITH 950 SQUARE INCHES, MINIMUM, OF CHARGING AIR COOLER. CONTRACTOR TO SPECIFY FRONTAL AREA AND AMBIENT TEMPERATURE RATING.	<u>X</u>	___
<b>BUG SCREEN:</b>	RADIATOR- MOUNTED BEHIND GRILLE 1/4" GRID STEEL SCREEN. SCREEN DOOR MATERIAL WILL NOT BE ACCEPTED.	<u>X</u>	___
<b>ELECTRICAL SYSTEM:</b>	12 VOLT, 3 MAINTENANCE FREE BATTERIES, 1950 CCA, MINIMUM, OR EQUAL, ALUMINUM BATTERY BOX PREFERRED <b>WITH JUMP START CABILITIES EXTERNAL OF BATTERY BOX OR AT ENGINE.</b> ALTERNATOR RATED AT 130 AMP CAPACITY. STARTER 12-VOLT WITH THERMAL OVER CRANK PROTECTION. CIRCUIT BREAKERS WITH MANUAL RESET (MAIN PANEL) SAE TYPE III OR EQUAL WITH TRIP INDICATORS	<u>X</u>	___
<b>STEERING:</b>	POWER, HEAVY DUTY, FULL HYDRAULIC, (2) SHEPPARD M-90/M-80, DUAL POWER OR EQUAL	<u>X</u>	___
<b>AIR COMPRESSOR:</b>	16.0 CFM, MINIMUM, WATER COOLED, BENDIX TU-FLO 750 OR EQUAL.	<u>X</u>	___
<b>BRAKES:</b>	FULL AIR WITH WATER FILTERS/DRIERS, AUTOMATIC DRAIN VALVE, BENDIX ANTILOCK BRAKE SYSTEM OR EQUAL. COLOR CODED NYLON BRAKE LINES OR EQUAL, AIR LINES INSIDE FRAME TO MEET ALL REGULATIONS. FRONT AND REAR AUTOMATIC SLACK ADJUSTERS, FRONT BRAKES S-CAM TYPE, 16.5" BY 5.0" MINIMUM, REAR BRAKES S-CAM TYPE, 16.5" X 7.0" MINIMUM.	<u>X</u>	___
<b>PARKING BRAKE:</b>	PIGGY BACK WITH AUXILIARY TANK	<u>X</u>	___
<b>FRAME:</b>	FRAME RAILS HEAT TREATED ALLOY STEEL OR EQUAL, (110,000 PSI YIELD); 10.125" X 3.502" X 0.312"; 199" THRU 228" WB WITH 92" MAXIMUM AF OR EQUAL. FRAME REINFORCEMENT OUTER "C" CHANNEL, HEAT TREATED ALLOY STEEL, (110,000 PSI YIELD); 10.813" X 3.812" X 0.312"; 199" THRU 228" WB WITH 92" MAXIMUM AF OR EQUAL, MINIMUM 2,800,000 RBM.	<u>X</u>	___
<b>FRONT AXLE:</b>	I-BEAM TYPE (MERITOR (ROCKWELL) FL-941 OR EQUAL, 18,000-LB CAPACITY OR EQUAL,	<u>X</u>	___

**ATTACHMENT B – SPECIFICATION** (continued)**CHECK-LIST FOR****Group 2 – One (1) 4000 GALLON STAINLESS STEEL TANK WATER TRUCK**

<b><u>BIDDERS SHALL FILL IN THE FOLLOWING:</u></b>		<b><u>YES</u></b>	<b><u>NO</u></b>
<b>FRONT SUSPENSION:</b>	FRONT SPRINGS MULTILEAF, SHACKLE TYPE, 18,000-LB CAPACITY LESS SHOCK ABSORBERS	<u>X</u>	___
<b>PROPSHAFTS:</b>	1810 HEAVY DUTY MAIN WITH 1710 HD INTER-AXLE.	<u>X</u>	___
<b>REAR AXLES:</b>	TANDEM, MERITOR (ROCKWELL) MT-40-14X-P OR EQUAL, SINGLE REDUCTION 40,000 LB CAPACITY WITH DRIVER CONTROLLED MAIN LOCKING DIFFERENTIAL IN REAR-REAR AXLE, LUBE OIL PUMP AND 200 WHEEL ENDS OR EQUAL. VEHICLE WILL NEED TO REACH A SPEED OF 75 MPH AROUND A 4.88 GEAR RATIO. CONTRACTOR TO STATE.	<u>X</u>	___
<b>REAR SUSPENSION:</b>	TANDEM, (HENDRICKSON HN-402-52) OR EQUAL WALKING BEAM TYPE 52" AXLE SPACING, 40,000 LB CAPACITY, WITH RUBBER SPRINGS, WITH RUBBER END BUSHINGS, SHOCK ABSORBERS AND TRANSVERSE TORQUE RODS WITH BAR PIN TYPE BEAM END ADAPTERS OR EQUAL. CONTRACTOR TO STATE.	<u>X</u>	___
<b>WHEELS:</b>	FRONT DISC, 22.5" PAINTED STEEL, WHITE, 10-STUD HUB PILOTED, FLANGED NUT, METRIC MOUNT, 8.25 DC RIMS WITH STEEL HUBS OR EQUAL. REAR DUAL DISC, 22.5" PAINTED STEEL, WHITE, 10-STUD, HUB PILOTED, FLANGED NUT, METRIC MOUNT, 9.00 DC RIMS, WITH STEEL HUBS. REAR WHEEL SEALS (STEMCO GUARDIAN) OR EQUAL, OIL LUBRICATED WHEEL BEARINGS. FRONT WHEEL SEALS (STEMCO GUARDIAN) OR EQUAL, OIL LUBRICATED WHEEL BEARINGS.	<u>X</u>	___
<b>TIRES:</b>	FRONT, (2) 315/80R22.5 UNISTEEL AMO6 (HANKOOK) OR EQUAL, LOAD RANGE L, 20 PLY. REAR, (8) 11R22.5 UNISTEEL G167A (GOODYEAR) OR EQUAL, LOAD RANGE H, 16 PLY. TRAC.	<u>X</u>	___
<b>BUMPER:</b>	HEAVY DUTY, PAINTED STEEL, SWEEP BACK OR EQUAL. TWO FRONT FRAME MOUNTED TOW HOOKS.	<u>X</u>	___
<b>CAB:</b>	CONVENTIONAL, INSULATED, WITH FIBERGLASS TILT HOOD AND FENDERS WITH GRILL. FULL TINTED GLASS, DUAL AIR HORNS, RECTANGULAR CONVEX MIRROR MOUNTED ABOVE RIGHT DOOR FOR BLIND SPOTS NEXT TO RIGHT SIDE OF CAB, RETRACTABLE MIRRORS BOTH SIDES APPROXIMATELY 7" X 16" WITH NON-MOTORIZED MIRROR HEADS WITH SEPARATE 8" CONVEX SPOT MIRRORS, GRAB HANDLES EACH SIDE, TURN SIGNALS, MARKER LIGHTS, AND REFLECTORS TO MEET ALL REGULATIONS. ELECTRIC HORN UNDER HOOD, HEAVY DUTY WINDSHIELD WIPERS, STEPS ON EACH SIDE FOR ENTRANCE.	<u>X</u>	___

**ATTACHMENT B – SPECIFICATION** (continued)  
**CHECK-LIST FOR**

**Group 2 – One (1) 4000 GALLON STAINLESS STEEL TANK WATER TRUCK**

**BIDDERS SHALL FILL IN THE FOLLOWING:**

	<u>YES</u>	<u>NO</u>
<b>CAB INTERIOR:</b>		
DRIVER SEAT (BOSTROM 910, S/N830068177 MDL T-910) OR EQUAL, AIR SUSPENSION, INTERMEDIATE BACK, ALL OR PART CLOTH, ISOLATED, ADJUSTER, AIR LUMBAR SUPPORT, SEAT CUSHION AND SEAT BACK ANGLE ADJUSTMENT, LEFT SIDE ARM REST MOUNTED INBOARD, WITH VOCATIONAL TRIM LEVEL. PASSENGER SEAT (NATIONAL STATIC MODEL 192) OR EQUAL, NON-SUSPENSION, HIGH BACK, ALL CLOTH WITH RIGHT SIDE ARM REST, WITH VOCATIONAL TRIM LEVEL. SEAT BELTS, 3-POINT LAP AND SHOULDER BELT TYPE. HEATER AND DEFROSTER WITH FRESH AIR PROVISION, WITH PREMIUM HEATER HOSES. INTERIOR TRIM VOCATIONAL LEVEL; VINYL OR EQUAL. TWO SUNVISORS, DOME LIGHT. 17" TO 21" DIAMETER STEERING WHEEL. DUSTPROOF, WATERPROOF CONTAINER TO STORE VALUABLE DOCUMENTS, TWO COAT HOOKS, ADDITIONAL POWER OUTLET FOR CELL PHONE. <b>ADDITIONAL AIR OFF SEAT WITH 4 FOOT COILED AIR LINE WITH BLOW GUN ATTACHED.</b>	<u>X</u>	—
<b>FUEL TANKS:</b>		
SINGLE 95 GALLON MINIMUM <b>NON-POLISHED ALUMINUM TANK</b> MOUNTED LEFT SIDE UNDER CAB. TRUCK IS DRIVEN OFF ROAD AND NEEDS MAXIMUM GROUND CLEARANCE.	<u>X</u>	—
<b>FUEL FILTERS:</b>		
TWO EACH, SCREW ON, ONE AT ENGINE, ONE AT TANK WITH WATER SEPARATOR	<u>X</u>	—
<b>RADIO:</b>		
AM-FM STEREO, FACTORY ELECTRONIC TUNING AND CLOCK, MULTIPLE DUAL CONE SPEAKERS (2) MINIMUM. MOUNTED ANTENNA OR EQUAL.	<u>X</u>	—
<b>AIR CONDITIONING:</b>		
MAXIMUM AVAILABLE, FACTORY INSTALLED, INTERNAL CAB - NO ROOF MOUNTING	<u>X</u>	—
<b>INSTRUMENTATION:</b>		
SPEEDOMETER, ODOMETER, OIL PRESSURE GAUGE, WATER TEMPERATURE GAUGE, ENGINE HOUR METER, VOLT METER, FUEL GAUGE, TACHOMETER, DUAL AIR PRESSURE GAUGES,	<u>X</u>	—



**ATTACHMENT B – SPECIFICATION** (continued)

**CHECK-LIST FOR**

**Group 2 – One (1) 4000 GALLON STAINLESS STEEL TANK WATER TRUCK**

**BIDDERS SHALL FILL IN THE FOLLOWING:**

**YES    NO**

<b>AUTOMATIC WARNING SYSTEM</b>	SEPARATE AUDIBLE (ABOVE AMBIENT LEVELS) ALARMS FOR LOW ENGINE OIL PRESSURE, ENGINE OVER TEMPERATURE, LOW AIR PRESSURE. <b>SHUTDOWN SYSTEM SHALL BE ACTIVATED TO SENSE THE SLIGHTEST VARIATION OF THESE THREE SYSTEMS, IF FAILING, AND AUTOMATTICALLY SHUT THE ENGINE DOWN TO PREVENT ENGINE DAMAGE. CONTRACTOR TO STATE WHICH SYSTEMS WILL BE MONITORED BY THE AUTO SHUT/DOWN SYSTEM.</b>		
	<b>TYPE OF SYSTEM:</b> <u>Oil Pressure, Temperature, Air Pressure</u>	<u>X</u>	—
<b>FENDERS:</b>	FENDERS MADE WITH DUMP BED FEDERAL LEGAL MUDFLAPS TO COVER REAR WHEELS, ANTI-SAIL TYPE. (2) BEHIND FRONT TIRES.	<u>X</u>	—
<b>RADIO NOISE SUPPRESSION:</b>	UNIT WILL BE EQUIPPED WITH AM AND MOBILE RADIO NOISE SUPPRESSION PACKAGE. ELECTRIC AND ELECTRONIC COMPONENTS OF THE UNIT SHALL NOT INTERFERE WITH SIGNALS RECEIVED OR TRANSMITTED BY THE MOBILE RADIO SYSTEM, NOR SHALL THE ELECTRIC AND ELECTRONIC COMPONENTS OF THE UNIT BE AFFECTED BY THE OPERATION OF THE MOBILE TRANSMITTER OR RECEIVER.	<u>X</u>	—
<b>BACK-UP ALARM:</b>	ELECTRIC BACKUP ALARM, 97dB MINIMUM. WEATHERPROOF AND STEAM-CLEANABLE.	<u>X</u>	—
<b>COLOR:</b>	CAB, BODY AND WHEELS - STANDARD WHITE FRAME - STANDARD BLACK	<u>X</u>	—
<b>WEIGHT DISTRIBUTION:</b>	CONTRACTOR TO SUPPLY WITH BID CHART DETAILING WEIGHT ON AXLES WITH FULL LOAD TO INCLUDE NET LEGAL PAYLOAD CAPACITY.	<u>X</u>	—
<b>SAFETY EQUIPMENT:</b>	FIRE EXTINGUISHER (5LB ALL PURPOSE) MOUNTED IN CAB, WITHIN EASY REACH OF THE OPERATOR, SAFETY TRIANGLE KIT IN CAB, ALL LADDERS, STEPS AND WALKING AREAS SHALL BE NON-SLIP TYPE.	<u>X</u>	—

**ATTACHMENT B – SPECIFICATION (cont)**

**CHECK-LIST FOR**

**Group 2 – One (1) 4000 GALLON STAINLESS STEEL TANK WATER TRUCK**

**BIDDERS SHALL FILL IN THE FOLLOWING:**

**YES    NO**

**BODY:**

WATER TANK (MATERIAL SHELL, ENDS, BAFFLES AND BELLY PLATE) SHALL BE CONSTRUCTED OF A MINIMUM OF 7-GAUGE STAINLESS STEEL. FRONT AND CENTER WATER TANK MOUNTS SHALL BE SPRING MOUNTED AND THE REAR TANK MOUNT SHALL BE SOLID MOUNTED TO PREVENT CRACKING OR BREAKAGE IN THE TANK. TANK WILL BE 4000 GALLON APPROXIMATE. 96"W x 62"H x 180"L SHAPE MODIFIED ELLIPSE MOUNTED TO PROVIDE LOWEST CENTER OF GRAVITY. TANK ENDS WELDED 360 DEGREES ON BOTH SIDES, BAFFLES (2) EVENLY SPACED WITH AN 20" CRAWL HOLE, WELDED 360 DEGREE ON BOTH SIDES. TOP OF TANK A 25" DIA. MANHOLE FOR FILLING, INSPECTIONS, AND MAINTNANCE APPROXIMATELY 4" HIGH WITH HINDGED COVER AND NON-SKID RIGHT SIDE OF FRAME TO HAVE SIGN RACKS TO FIT 3 SIGNS AT SIGN BRACKET SPACING FROM 19-24 INCHES. (PICTURE #1) LADDER, HAND HOLDS, NON-SKID STEPS TO LADDER **SHOWN IN THE PICTURE** FOR STEPS AND HAND HOLD AND WALKWAY FOR ACCESS MOUNTED ON REAR OF TANK. A TOOL BOX BUILT BETWEEN THE FRAME IN THE RAR OF TRUCK TO BE FRAME WIDTH AND DEPTH AND APPROXIMATELY 24" LONG, BOTTOM AND FRONT SIDE MADE WITH STRETCH METAL MINIMUM OF 1/8<sup>TH</sup> THICK STEEL, ALONG WITH A LOCKABLE HINDGED LID. WATER TANK SHALL BE MOUNTED WITH (3) MOUNTS PER SIDE WITH VULCANISED WEAR SPACER OR EQUAL MOUNTED BACK FLOW DEVICE BRACKETS MOUNTED ON THE LEFT REAR SIDE OF FRAME AND LOCK PINS. (PICTURE) TWO (2) WORK LIGHTS ON THE REAR OF TANK, CONTOLS INSIDE CAB. (PICTURE)

COMPLY

X        

**DRAIN:**

DRAIN AND SUMP WITH ANTI-SWIRL BAFFLE DRAIN 4" NPT WITH WELDED FLANGE

COMPLY

X        

**FILL SYSTEM:**

FILL PIPE SHALL BE PERMANENTLY PLUMBED INTO THE REAR OF TANK WITH A ONE WAY VALVE. A PLATFORM AND ROUGH PLUMBING FOR CITY OF TUCSON WATER METER (MOUNTING AND INSTALLATION WILL BE PERFORMED BY PIMA COUNTY AT A LATER DATE) PUMP INTAKE PLUMBED TO HAVE POND FILL PICK-UP SIGHT GAUGE SHALL BE PLACED IN THE FRONT AND REAR OF TANK AT THE FILL PIPE TO ALLOW OPERATOR TO OBSERVE TANK LEVEL, WITH SHUTOFF VALVES AT EACH END, REAR MOUNTED ON THE TANK OVERFLOW PIPE WITH MANUAL VALVE TO INDICATE WHEN LEGAL WEIGHT LIMIT IS REACHED WHEN TANK IS FILLED WITH WATER WEIGHTING 8.3 POUNDS PER GALLON.

COMPLY

X        

**POWER TAKE OFF:**

AIR OPERATED HOT SHIFT WITH ADJUSTABLE OVERSPEED CONTROL AND CAB MOUNTED PTO ON INDICATER LIGHT.

COMPLY

X

**ATTACHMENT B – SPECIFICATION (con't)****CHECK-LIST FOR****Group 2 – One (1) 4000 GALLON STAINLESS STEEL TANK WATER TRUCK****BIDDERS SHALL FILL IN THE FOLLOWING:****YES NO**

<b>HYDRAULIC PUMP:</b>	HEAVY DUTY, CAST IRON REBUILDABLE, INTEGRAL PUMP AND CONTROL VALVE. APPROXIMATELY 27 GPM AND 2,000 PSI CAPACITY. HOT SHIFT CONTROL, PRESSURE LUBRICATED.	COMPLY	<u>X</u> —
<b>SPRAY SYSTEM:</b>	PTO DRIVEN HYDRAULIC PUMP TO TURN HYDRAULIC MOTOR ON WATER PUMP WITH SUFFICIENT HYDRAULIC COOLER. CAST IRON AND REBUILDABLE WATER PUMP EQUAL TO A BERKLEY/PENTAIR MODEL B4ZRKS TO DELIVER 600 GPM TO SPRAY HEADS. PUMP MOUNTING BRACKET PLATFORM NEEDS TO HAVE A MINIMUM OF 12 INCH GROUND CLEARANCE RIGHT HAND SIDE MOUNTED FLUSHER. RIGHT HAND CENTER MOUNTED SPRAY HEAD WITH SEPARATE AIR OPERATED VALVE FIVE (5) 3" SPRAY HEADS WITH 360 DEGREE SWIVEL LOCATED AS FOLLOWS: (2) SPRAY HEADS LOCATED AT THE REAR CORNERS OF TANK (2) SPRAY HEADS LOCATED IN FRONT CORNER OF TRUCK TOP OF BUMPER (1) SPRAY HEAD LOCATED TOWARD BOTTOM, FRONT OF TANK RIDE SIDE AIR OPERATED WITH INDIVIDUAL CONTROLS TO ACTUATE EACH OF THE FIVE (5) SPRAY HEADS. A 2" JET VALVE MOUNTED AT THE FRONT MANIFOLD SCHEDULE 40 BLACK PIPE USED EXCLUSIVELY ON PLUMBING SYSTEM. SOFT COUPLER INSTALLED WHERE TRUCK PLUMBING MEETS THE TANK TO PREVENT WELDED PIPES FROM CRACKING. RAVITY BAR WITH DETACHABLE END CAPS FOR CLEANING PURPOSES AND AIR OPERATED VALVE AND MANUAL OVERRIDE VALVE. NON-PRESSURIZED, GRAVITY FLOW HOSE FITTING TO BE PLUMBED INTO PIPING AT REAR.	COMPLY	<u>X</u> —
<b>LIGHTS:</b>	LIGHTS AND REFLECTOR SHALL MEET DOT REQUIREMENTS. ALL LIGHTS SHALL BE SEAL BEAM HEADLIGHTS AND ALL OTHER LIGHTS TO BE LED OR EQUAL AND (2) FEDERAL SIGNAL QUADAFLARE MODEL #QL-64-XFA (PICTURE) WARNING LIGHTS MOUNTED IN THE REAR OF TRUCK. TAILLIGHT AND BRAKE LIGHTS SHALL BE BUILT INTO THE BODY TO KEEP CLEAN FROM DEBRIS. REAR MOUNTED WORK LIGHTS (2) AT RAER OF TANK WITH SWITCHES IN CAB (PICTURE)	COMPLY	COMPLY <u>X</u> —
<b>PAINT:</b>	ALL MILL SCALE SHALL BE REMOVED PRIOR TO PRIMER COAT AND TWO COATS, MINIMUM, OF PURE WHITE URETHANE APPLIED OR EQUAL.	COMPLY	<u>X</u> —

**ATTACHMENT B – SPECIFICATION (con't)**

**CHECK-LIST FOR**

**Group 2 – One (1) 4000 GALLON STAINLESS STEEL TANK WATER TRUCK**

**BIDDERS SHALL FILL IN THE FOLLOWING:**

**YES    NO**

**TRAILER PACKAGE:** HOLLAND PH-200 OR EQUAL RIGID TYPE  
PINTLE HOOK WITH AIR-OPERATING PLUNGER,  
18,000 LBS MAXIMUM VERTICAL LOAD 80,000  
LBS. G.C.W. (120,000 LB TENSILE) ELECTRICAL  
TRAUKER BRAKE AND LIGHT HOOK UP.  
THERE SHALL ALSO BE AJR BRAKE LINES,  
VALVES, AND GLAD-HANDS CONNECTIONS  
TO THE REAR OF THE TRUCK FOR PULLING AIR  
BRAKE TRAILTERS AND HEAVY DUTY D RINGS  
FOR SAFETY CHAINS

**COMPLY**

X    \_\_\_\_\_

**WEIGHT  
CERTIFICATE:** AT TIME OF DELIVERY TO PIMA COUNTY  
CONTRACTORS SHALL FURNISH WEIGHT  
CERTIFICATE FROM STATE OF ARIZONA  
LICENSED PUBLIC WEIGHMASTER SHOWING  
THE WEIGHT OF VEHICLE FULLY BUILT.

**COMPLY**

X    \_\_\_\_\_

**INSPECTION: AFTER TRUCK IS BUILT, CONTRACTOR SHALL HAVE TRUCK INSPECTED BY STATE OF ARIZONA MOTER VEHICLE DIVISION. INSPECTION SLIP SHALL BE DELIVERED AT THE TIME OF THE TRUCK DELIVERY.**

**(THE REMAINDER OF THIS PAGE IS INTENTIONALLY LEFT BLANK)**

ATTACHMENT B – SPECIFICATION (continued)

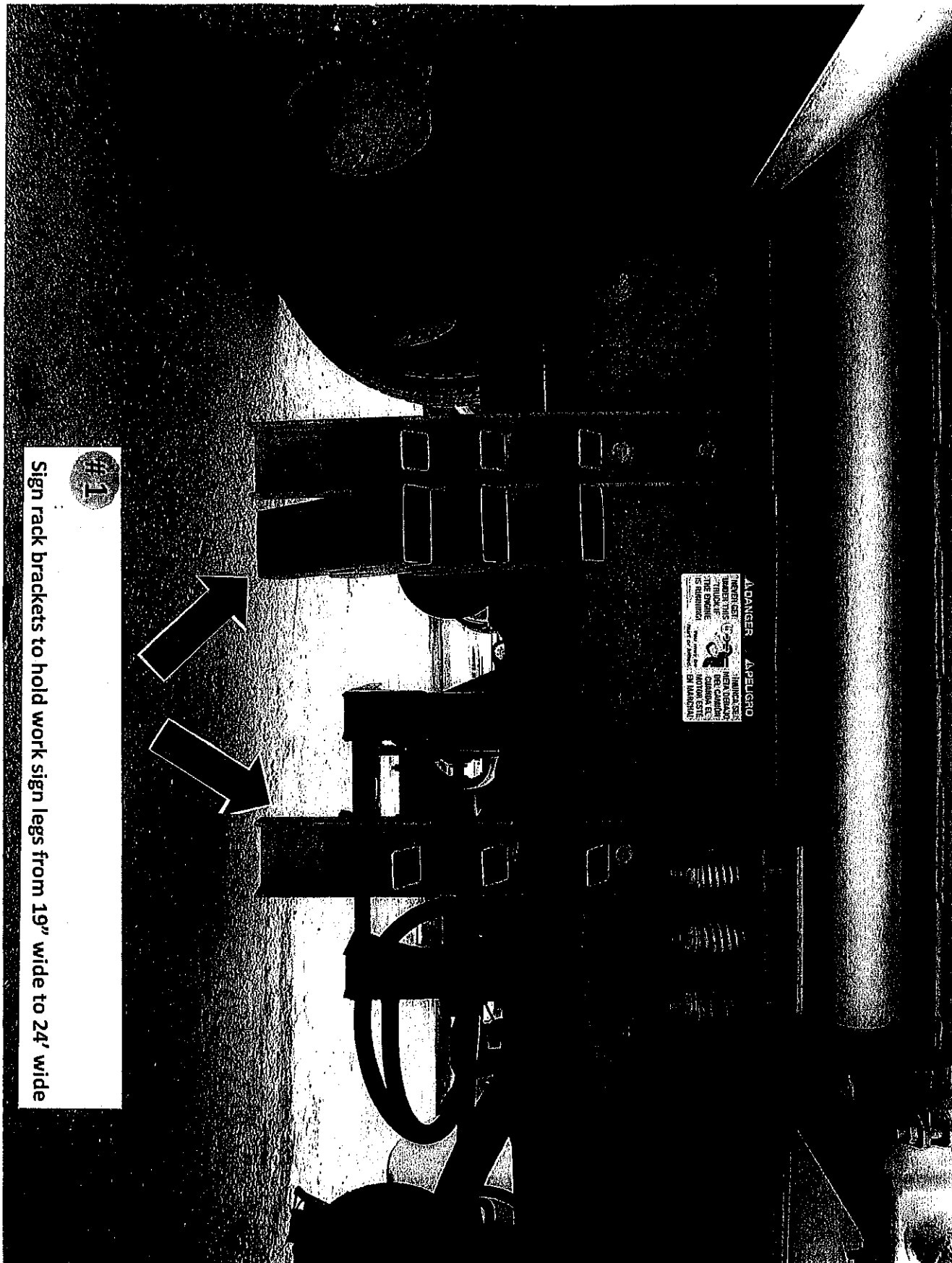

ATTACHMENT B – SPECIFICATION (continued)

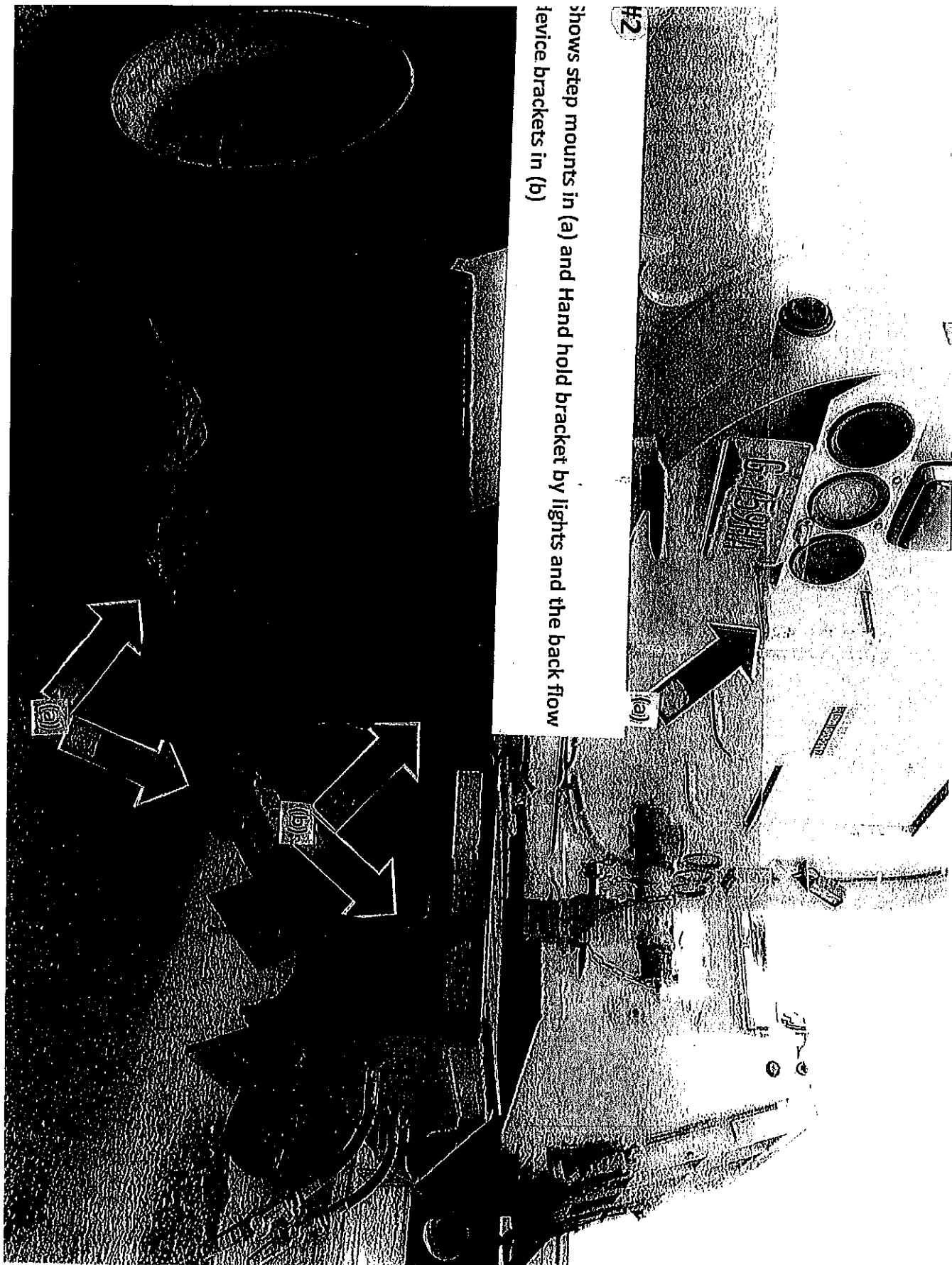

#2 shows step mounts in (a) and Hand hold bracket by lights and the back flow device brackets in (b)

ATTACHMENT B – SPECIFICATION (continued)

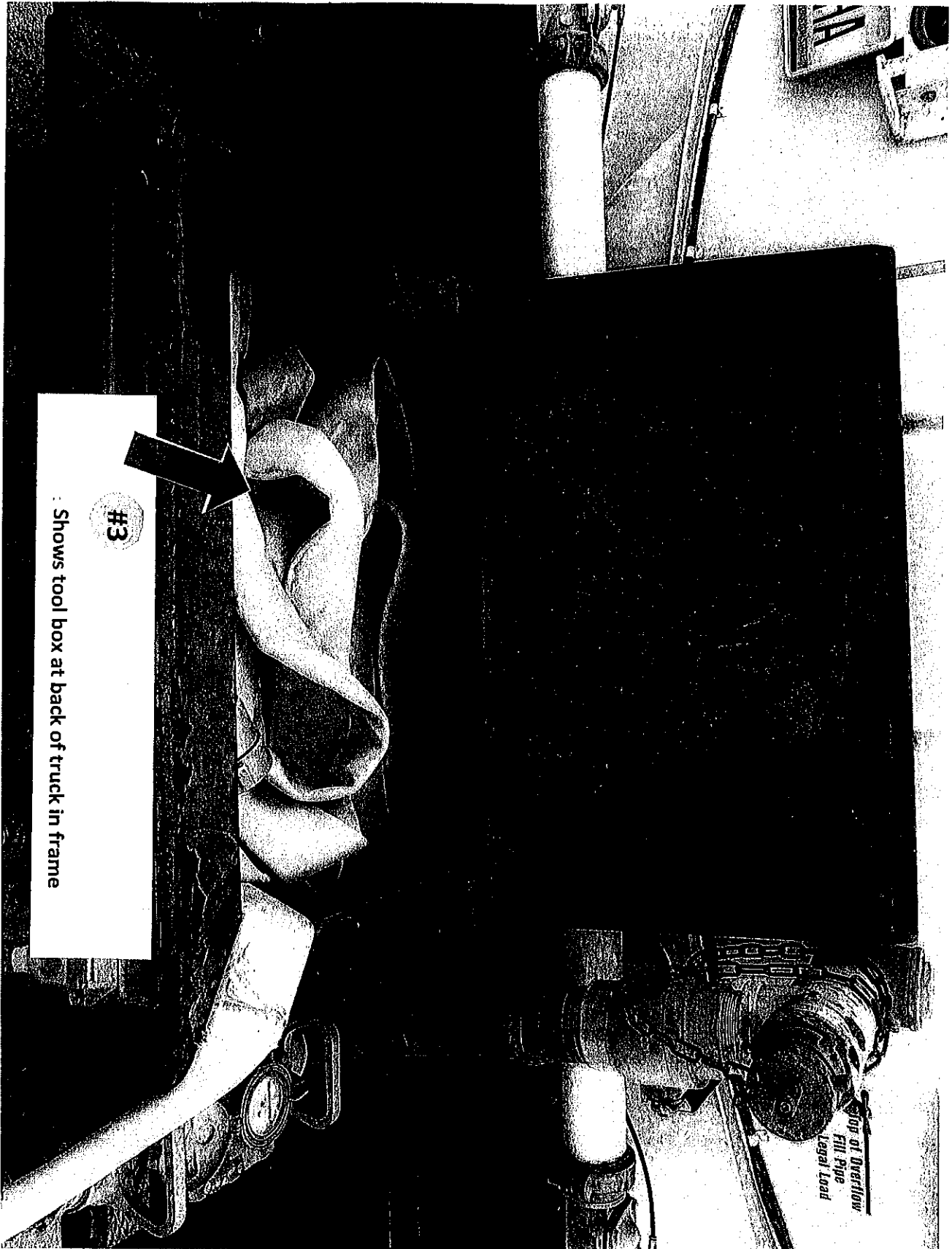

ATTACHMENT B – SPECIFICATION (continued)

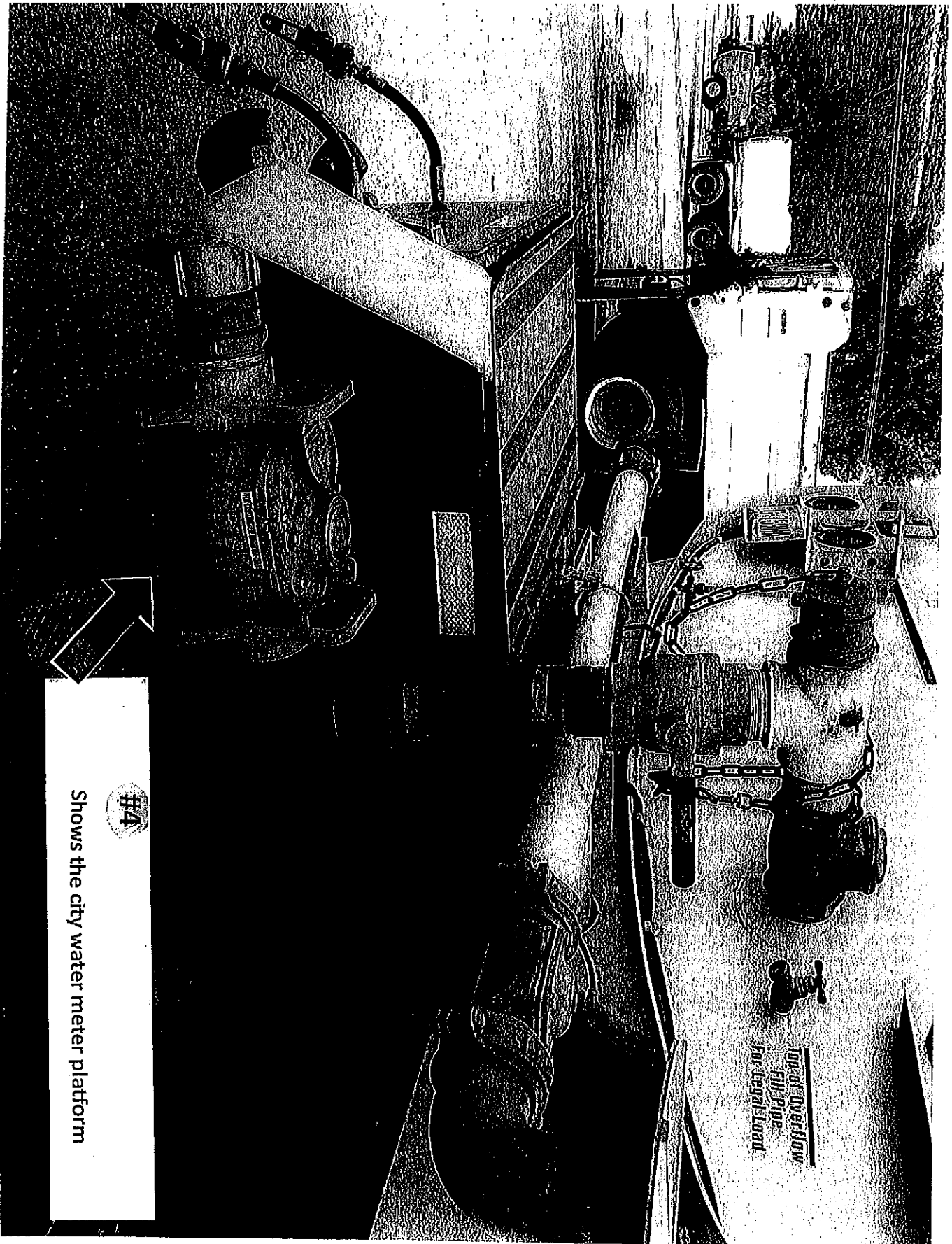

#4  
Shows the city water meter platform



ATTACHMENT B – SPECIFICATION (continued)

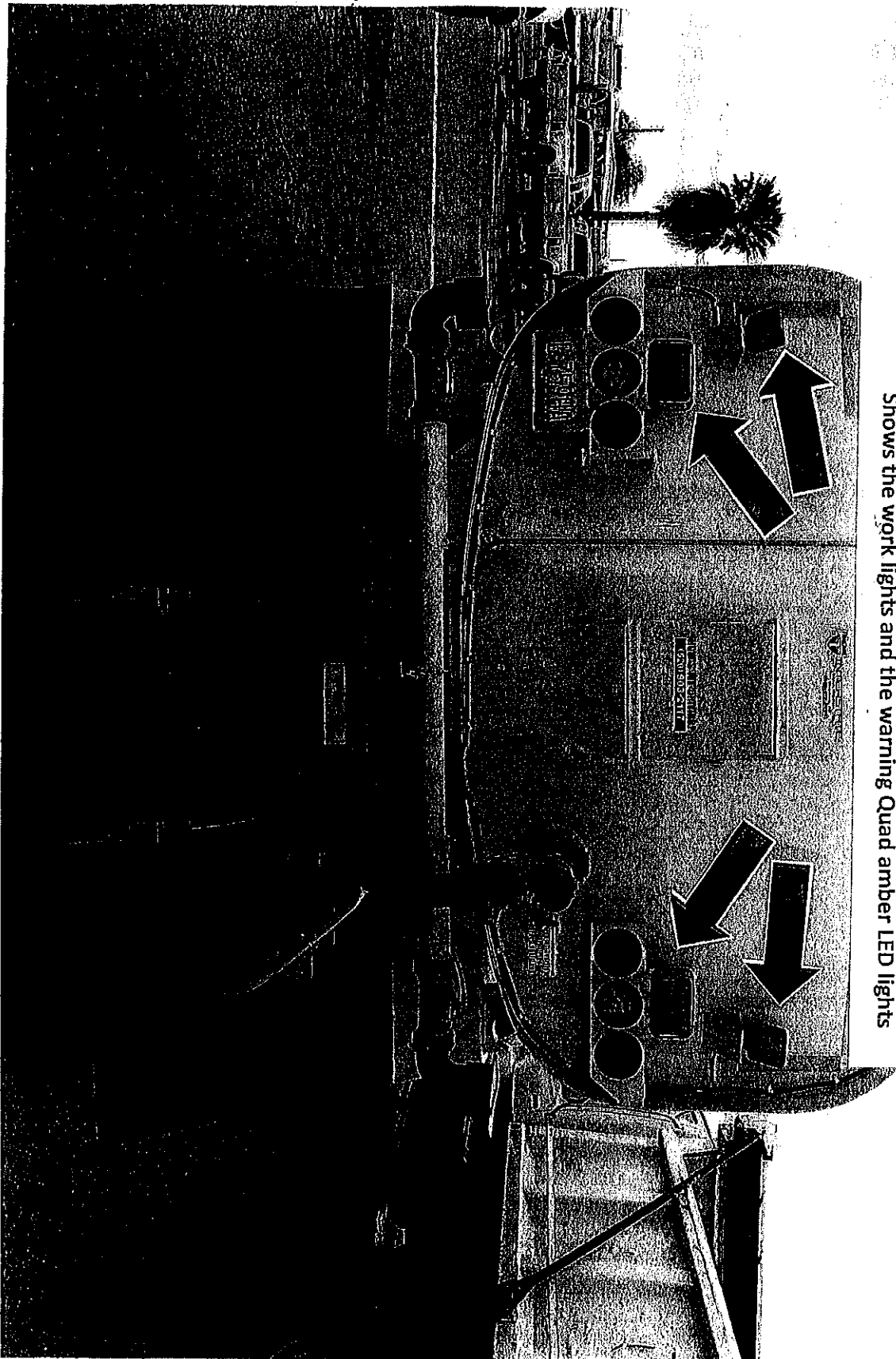

#5

Shows the work lights and the warning Quad amber LED lights

ATTACHMENT B – SPECIFICATION (continued)

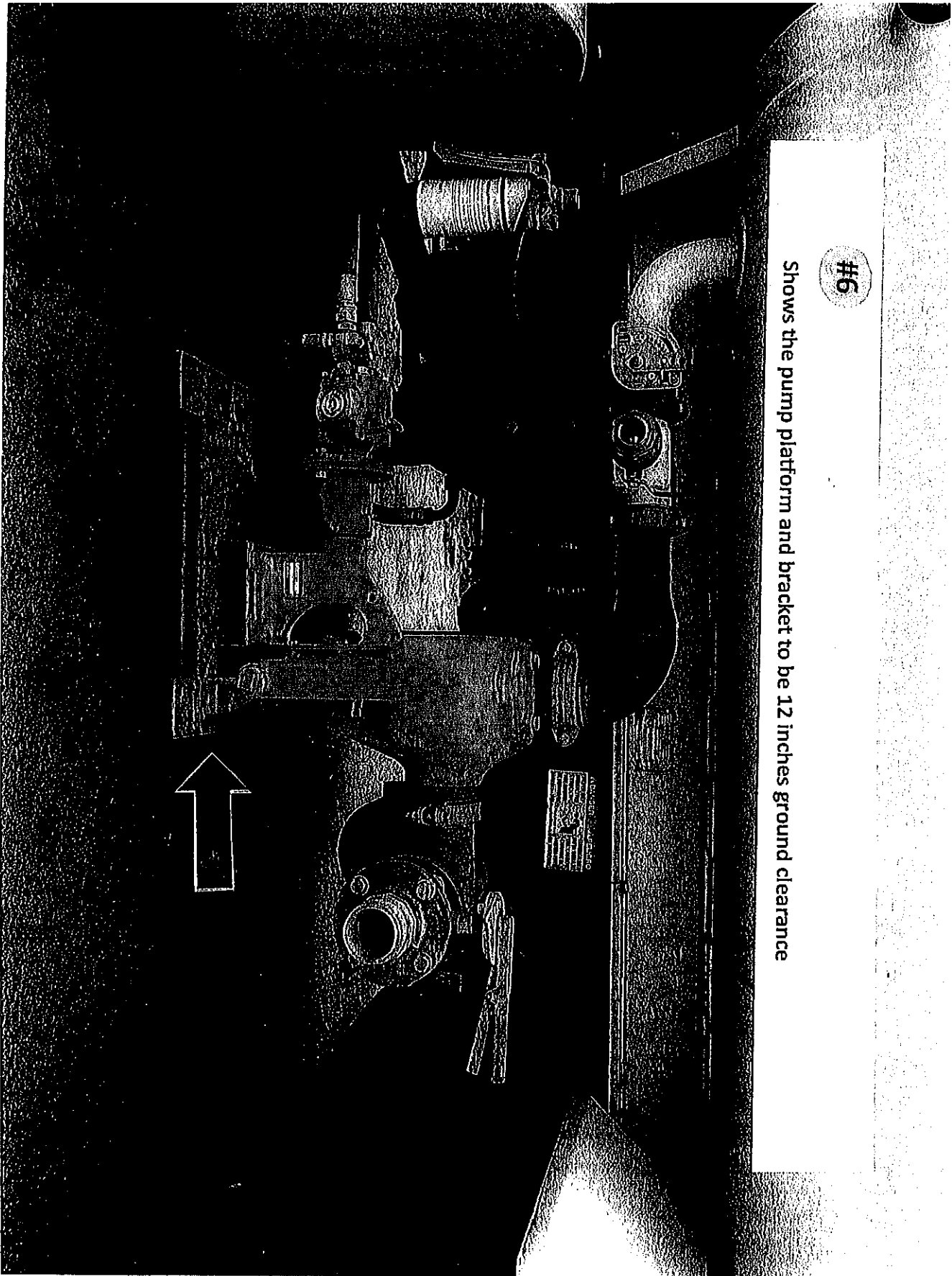

ATTACHMENT B – SPECIFICATION (continued)

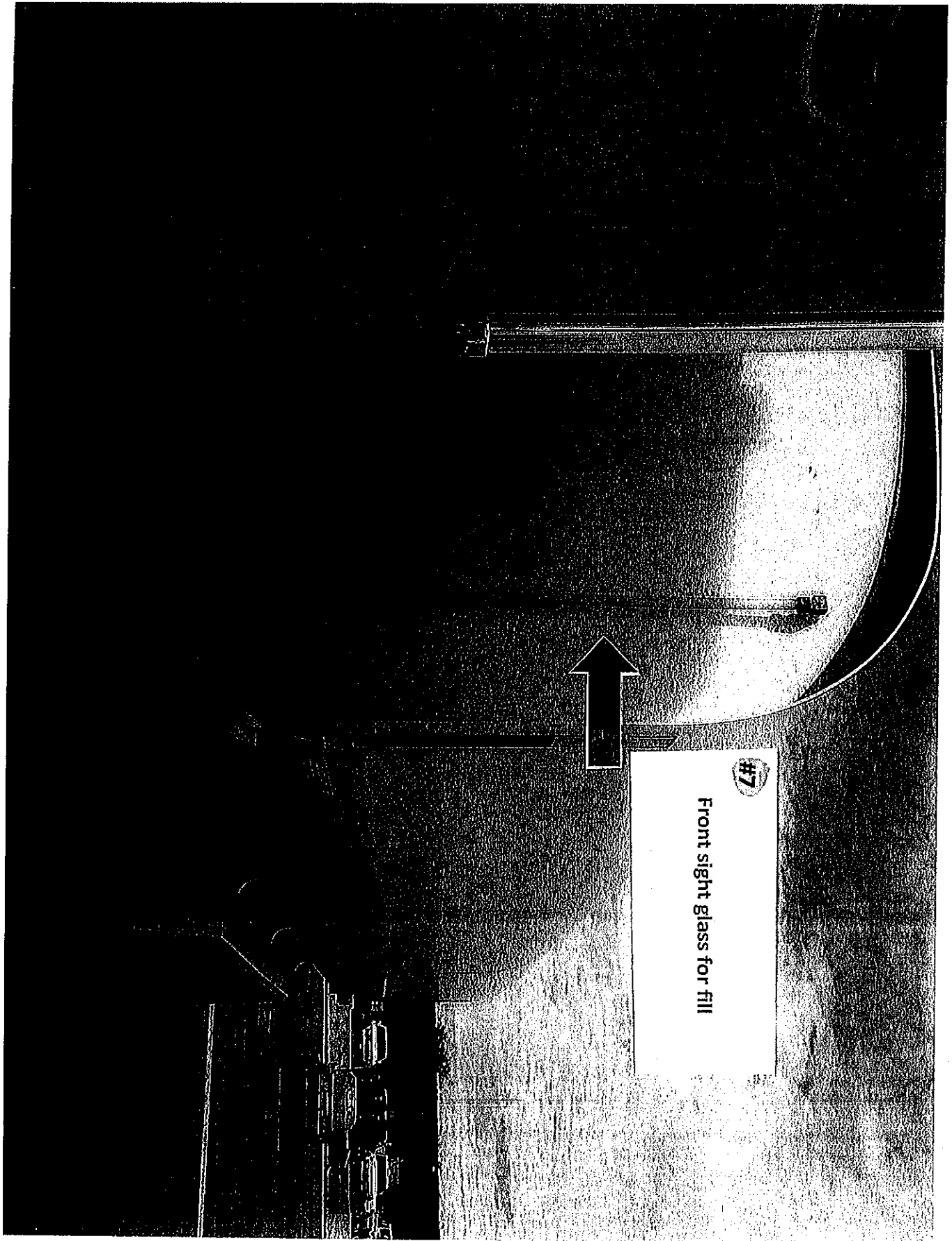

ATTACHMENT B – SPECIFICATION (continued)

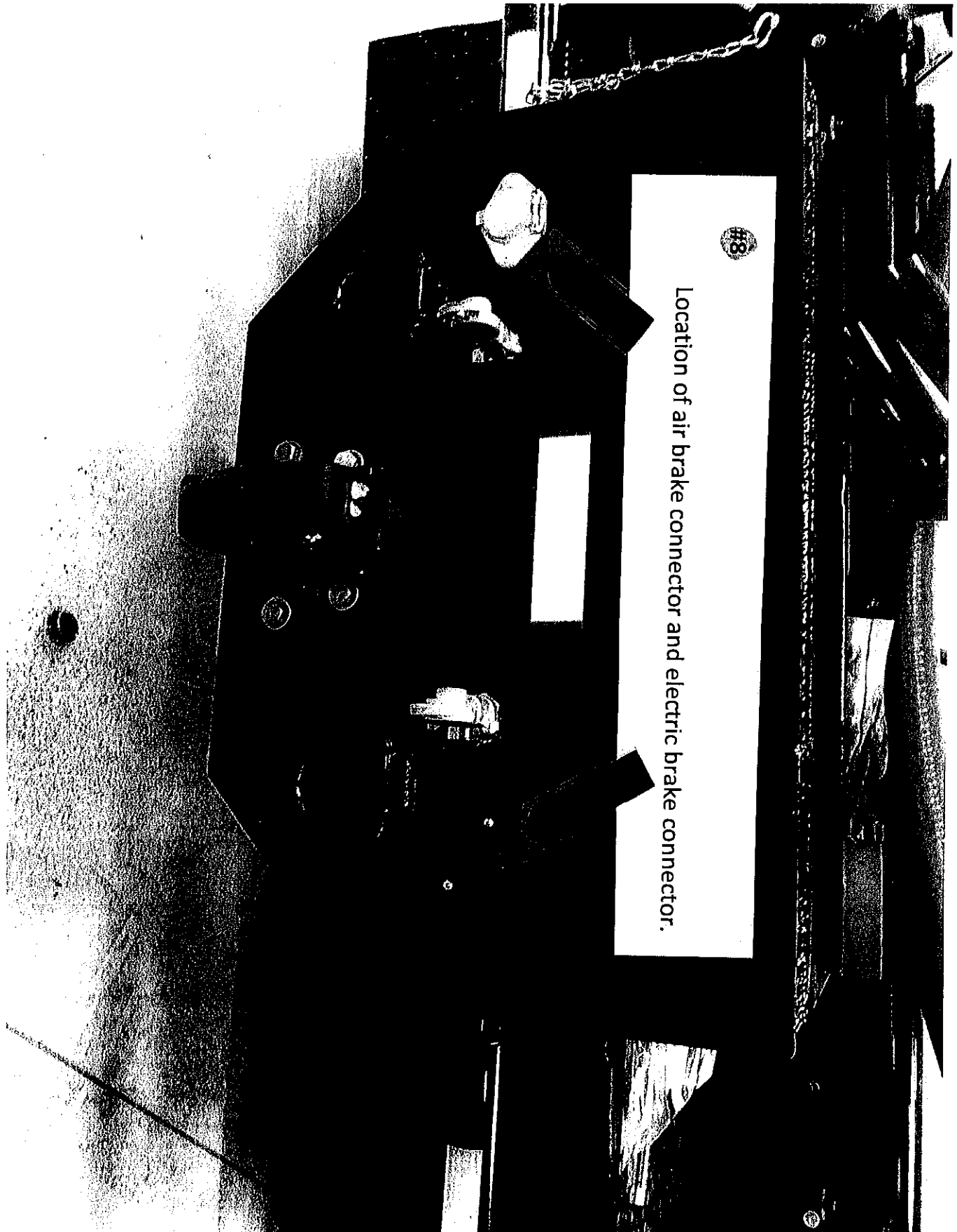

ATTACHMENT B – SPECIFICATION (continued)



ATTACHMENT B – SPECIFICATION (continued)

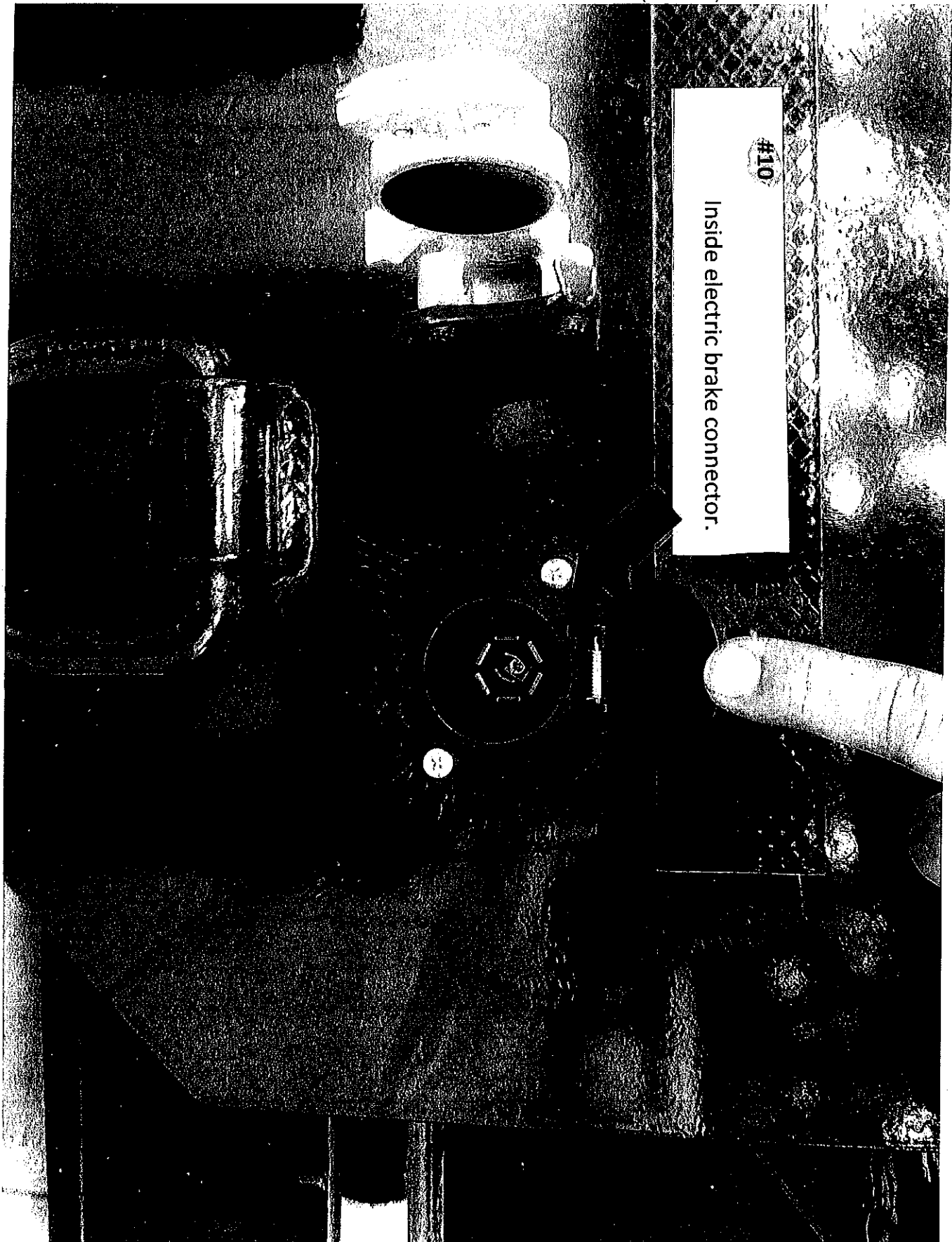

#10  
Inside electric brake connector.

END OF ATTACHMENT B: SPECIFICATIONS

ATTACHMENT "C"

CERTIFICATION OF STOCKING, SUPPLYING OF PARTS AND SERVICE PROGRAM

BIDDER SHALL CERTIFY THAT THEY ARE THE AUTHORIZED FACTORY REPRESENTATIVE AND GUARANTEE THAT THE EQUIPMENT THEY BID AND FURNISH TO PIMA COUNTY SHALL BE COVERED BY MANUFACTURER'S WARRANTY FOR A ONE (1) YEAR PERIOD UNLIMITED MILES AND HOURS (ENGINE HAS A 5 YR./150,000 MILE WARRANTY WITH A MANUFACTURER'S STATED HOURLY WARRANTY AND THE TRANSMISSION HAS A 5 YR./250,000 MILE WARRANTY WITH A MANUFACTURER'S STATED HOURLY WARRANTY. (SEE BELOW). BIDDER CERTIFIES THAT THEY DO STOCK AND MAINTAIN A COMPLETE LINE OF FACTORY PARTS AND MAINTAIN A COMPLETE SERVICE PROGRAM FOR THE AFOREMENTIONED EQUIPMENT THAT THEY BID. PLEASE FILL-IN ALL BLANK SPACES.

\* ENGINE WARRANTY TO COVER AT A MINIMUM: ENGINE COMPONENTS, TURBO(S), INJECTORS, WATER PUMP TO INCLUDE SEAL, ENGINE CONTROL MODULE, AND AFTER TREATMENT CONTROL MODULE AND SENSORS OR EQUIVALENT. NO DEDUCTIBLE.

\* ENGINE WARRANTY: 5 YEARS/150,000 MILE WARRANTY WITH A MANUFACTURER'S STATED HOURLY WARRANTY.

1 HOUR = N/A\* MILES

\*Engine warranty based on years/miles, no hourly limitations. 5 years/200,000 miles

\* TRANSMISSION WARRANTY: 5 YEARS/250,000 MILE WARRANTY WITH A MANUFACTURER'S STATED HOURLY WARRANTY.

1 HOUR = N/A\* MILES

\*Transmission warranty based on years/miles, no hourly limitations. 5 years/unlimited miles

NAME OF LOCAL WARRANTY REPAIR AGENCY: Freightliner of Arizona-Tucson

CLOSEST LOCATION OF PARTS: Freightliner of Arizona-Tucson

CONTACT NAME: Josh Lomeli TELEPHONE NUMBER: 520-449-8151

NAME OF LOCAL NON-WARRANTY REPAIR AGENCY: N/A

CLOSEST LOCATION OF PARTS: \_\_\_\_\_

CONTACT NAME: \_\_\_\_\_ TELEPHONE NUMBER: \_\_\_\_\_

PERCENTAGE DISCOUNT OFF OF PARTS: Fleet -10 % HOURLY CHARGE FOR LABOR: \$ 95 /HR

*\*Parts discounts vary from different manufacturers\**

FREE WEBSITE: www.DTNAsolutions.com

END OF ATTACHMENT C:

ATTACHMENT D - PRICING PAGE

Contractors may bid on one or all groups - award will be by group. All information under each group must be filled out in order for the response to be evaluated. Do not include sales tax in any prices. Unit price offered shall include all incidental and associated costs (excluding sales tax) required to comply with and satisfy all requirements referred to or included in this solicitation.

Group 1

ITEM	QTY.	DESCRIPTION	UNIT PRICE	EXTENDED PRICE
1.	2 ea	New 12 Yard Dump Trucks with semi-elliptical bed, Per specifications listed herein.	\$ 133,162.00	\$ 266,324.00
TOTAL GROUP 1:			\$	266,324.00

List the Brand/Model you are bidding: Freightliner 114SD-Interstate Dump Body Year: 2017

State the estimated delivery time if you receive the above order? 150-180 Days/Weeks ARO (circle one)

Pima County would like to receive these trucks prior to fiscal year end – **June 30, 2017**. Based on the estimated delivery time you stated above do you anticipate Pima County being able to receive these trucks prior to **June 30, 2017**?  
Yes X No \_\_\_\_\_ Explain: \_\_\_\_\_

Do not include tax in your prices.

Payment Terms: Net 30

Group 2

ITEM	QTY.	DESCRIPTION	UNIT PRICE	EXTENDED PRICE
1.	1 ea	New Water Trucks, Per specifications listed herein.	\$ 154,930.00	\$ 154,930.00
TOTAL GROUP 2:			\$	154,930.00

List the Brand/Model you are bidding: Freightliner 114SD-Interstate Water Tank Year: 2017

State the estimated delivery time if you receive the above order? 150-180 Days/Weeks ARO (circle one)

Pima County would like to receive these Water trucks prior to fiscal year end – **June 30, 2017**. Based on the estimated delivery time you stated above do you anticipate Pima County being able to receive these Water Trucks prior to **June 30, 2017**?  
Yes X No \_\_\_\_\_ Explain: \_\_\_\_\_

Do not include tax in your prices.

Payment Terms: Net 30

END OF ATTACHMENT D: PRICING PAGE



Freightliner (FTL)



**Run Smart™**

**Freightliner Level II (Factory released on or after 1/07/2013)**

Level II Coverage is not available for vehicles in these vocations:		Mining
Category Determinants		Models with Limitations
Road Surface— most severe in-transit between sites	Up to 30% off-highway Rough, maintained concrete/asphalt; maintained gravel/crushed rock; maintained dirt or soft soil	Up to 10% off-highway Columbia, Century, or Coronado Rough maintained concrete/asphalt; maintained gravel/crushed rock
GCW	140,000 lb/63 505 kg or less Doubles on NY turnpikes are rated 143,000 lb Doubles on FL turnpikes are rated 147,000 lb	
Axles and Their Manufacturer's GVW Rating		
	2-axle unit	49,000 lb/21 000 kg or less
	3-axle unit	69,000 lb/31 000 kg or less
	4-axle unit	89,000 lb/40 000 kg or less
	5 axles or more	98,000 lb/44 452 kg or less
Description	Time <sup>1</sup>	Distance <sup>1</sup>
Basic Vehicle	1 Year	100,000 mi/161 000 km
Battery	1 Year	100,000 mi/161 000 km
Brightwork	6 Months	Unlimited
Cab Corrosion/Perforation	5 Years	Unlimited
Cab Structure	3 Years	300,000 mi/483 000 km
Corrosion	6 Months	Unlimited
Crossmembers	5 Years	300,000 mi/483 000 km
Diesel Emission 2010 <sup>2</sup>	5 Years	100,000 mi/161 000 km
Drivetrain	2 Years	100,000 mi/161 000 km
Frame Rails	5 Years	300,000 mi/483 000 km
GHG14 <sup>3</sup> (Medium Heavy Duty to Heavy Heavy Duty Trucks)	5 Years	100,000 mi/161 000 km
GHG14 <sup>3</sup> (Medium Heavy Duty to Heavy Heavy Duty Tractors)	5 Years	100,000 mi/161 000 km
GHG14 <sup>3</sup> Tire	2 Years	24,000 mi/38 400 km
Paint	1 Year	100,000 mi/161 000 km
Paint, Chassis	6 Months	Unlimited

<sup>1</sup>Time or distance, whichever comes first

<sup>2</sup>Applies to vehicles equipped with EPA 2010 compliant diesel engines.

<sup>3</sup>Applies to models 2013 and later domiciled in the United States, check actual coverage online for coverage listed as "GHG14...".

**Warranty Statement & Warranty Coverage Descriptions follow on page three of this document.**

*The information provided in this document is for general information only and is not offered as customer's warranty.*

*This coverage may be superseded without notification.*

Copyright © Daimler Trucks North America LLC. All rights reserved. Daimler Trucks North America LLC is a Daimler company.

## Warranty Statement

### 1.00 NEW VEHICLE COVERAGE

The following section outlines Company standard warranty coverages for all Company vehicles, apparatus or chassis or cabs sold and domiciled in the USA (50 states and Washington, D.C.), and Canada. This information is also included in the Operator's Maintenance and Owner's Warranty Information Booklet.

### 1.01 NEW VEHICLE LIMITED WARRANTY

Under this New Vehicle Limited Warranty ("Warranty"), Company warrants that each new vehicle will be free from defects in material and workmanship that occur under normal use within the applicable warranty period, subject to certain limitations and exclusions as specified in this document.

This Warranty covers all components and parts unless specifically covered by other warranties or otherwise excluded by this document.

### 1.02 LIMITATIONS

This Warranty does not apply to vehicles that are sold or domiciled outside of the United States (50 states and Washington, D.C.), or Canada.

This Warranty does not apply to engines, Allison or Twin Disc transmissions, tires, or other components or parts that are not manufactured by Company and that are warranted directly by their respective manufacturers. With respect to the foregoing, Company makes no warranty whether express, implied, statutory or otherwise including, but not limited to, any warranty of merchantability or fitness for a particular purpose.

THIS WARRANTY IS EXCLUSIVE AND IN LIEU OF ALL OTHER WARRANTIES OF ANY KIND WHETHER WRITTEN, ORAL, OR IMPLIED INCLUDING, BUT NOT LIMITED TO ANY WARRANTY OF MERCHANTABILITY OR FITNESS FOR A PARTICULAR PURPOSE. THIS WARRANTY SPECIFICALLY EXCLUDES ANY OTHER WARRANTIES OR CONDITIONS PROVIDED FOR BY LAW, WHETHER STATUTORY OR OTHERWISE.

COMPANY'S SOLE OBLIGATION UNDER THIS WARRANTY SHALL BE TO REPAIR OR REPLACE, IN COMPANY'S SOLE DISCRETION, ANY DEFECTIVE COMPONENT OR PART. SUCH REPAIR OR REPLACEMENT SHALL BE WITHOUT COST TO PURCHASER WHEN PERFORMED WITHIN THE APPLICABLE WARRANTY PERIOD (TIME, DISTANCE, OR HOUR LIMIT, WHICHEVER OCCURS FIRST).

Purchaser must notify Company within the applicable warranty period, of any failure of the vehicle to comply with this Warranty and Purchaser must, at Purchaser's expense, promptly return the vehicle to an authorized Dealer for inspection and repair or replacement of any defect in material or workmanship occurring within the applicable warranty period.

The vehicle must be maintained and serviced according to the prescribed schedules outlined in the Driver's/Operator's and Maintenance Manuals. Receipted bills and other evidence that required maintenance and service have been performed are required by Company as a condition of this Warranty.

After the Company's obligations under this Warranty expire, all liabilities of Company to Purchaser under this Warranty shall terminate. Repairs made under this Warranty do not constitute an extension of the original Warranty period for the vehicle or for any specific component or part.

To the extent that any provision of this Warranty contravenes the law of any jurisdiction, such provision shall be inapplicable in such jurisdiction, and the remainder of the warranty shall not be affected.

### 1.03 PURCHASER'S EXCLUSIVE REMEDY

THIS WARRANTY SHALL BE THE PURCHASER'S SOLE AND EXCLUSIVE REMEDY AGAINST COMPANY, WHETHER IN CONTRACT, UNDER STATUTE (INCLUDING STATUTORY PROVISIONS AS TO CONDITIONS AS TO QUALITY OR FITNESS FOR ANY PARTICULAR PURPOSE OF GOODS SUPPLIED PURSUANT TO THE CONTRACT OF SALE), WARRANTY, TORT, STRICT LIABILITY, OR ANY OTHER LEGAL THEORY.

### 1.04 LIMITATION OF LIABILITY

COMPANY'S LIABILITY UNDER THIS WARRANTY IS LIMITED TO THE COST TO REPAIR OR REPLACE, IN COMPANY'S SOLE DISCRETION, THE DEFECTIVE COMPONENT OR PART THAT IN NO EVENT SHALL EXCEED THE FAIR MARKET VALUE OF THE VEHICLE AT THE TIME THE DEFECT IS DISCOVERED.

IN NO EVENT SHALL COMPANY BE LIABLE FOR SPECIAL, INDIRECT, INCIDENTAL, OR CONSEQUENTIAL DAMAGES INCLUDING, BUT NOT LIMITED TO, INJURIES TO PERSONS OR DAMAGE TO PROPERTY, LOSS OF PROFITS OR ANTICIPATED PROFITS, OR LOSS OF VEHICLE USE.

## Coverage Descriptions

### Axles

Coverage includes all factory-installed steer axles; drive axles; tag axles; and pusher axles. *Excludes any axle installed by a dealer or body builder.*

#### Drive Axle(s)

Coverage includes axle housing, carrier assembly, differential assembly, power divider, axle shafts, and gaskets and seals. *Excludes suspension and torque rod brackets, tie rod ends, wheel end equipment, wiring, yokes, and attaching hardware.*

#### Pusher Axle

A pusher axle is a non-driven, weight-bearing axle that can be raised when not required to bear a portion of the load. Since the pusher axle can be of many different configurations, warranty coverage includes all components included in the individual build specification of each individual application.

#### Steer Axle

Coverage includes I-beam, steering knuckles, differential on drive steer axle, spindles, kingpins, kingpin bearings and steering arms. *Excludes wheel end equipment, tie rod ends, steering linkage components, kingpin bushings, and king pin seals.*

#### Tag Axle

A tag axle is a non-driven, continuous weight-bearing axle. Since the tag axle can be of many different configurations, warranty coverage includes all components included in the individual build specification of each individual application.

### Battery

Only Freightliner LLC's private brand-label (Alliance Brand Parts), Mopar (Sterling Bullet only), and Furukawa (ST1360 Model only) batteries will be warranted. *Any other brand of battery is excluded from Company coverage. Claims for all other brands must be submitted directly to the supplier. Warranty coverage includes the battery assembly only.*

### Basic Body

Coverage includes body emergency lighting and controls; hinged and rollup compartment doors; body trim; body lighting and controls; body electrical systems.

### Basic Chassis

Coverage includes all factory-installed components of the vehicle/chassis that are not excluded elsewhere in the warranty, or by special agreement or described as having a different time, or distance or hours, or listed separately on each new vehicle warranty coverage chart.

### Basic Vehicle

Coverage includes all factory-installed components of the vehicle/chassis that are not excluded elsewhere in the warranty, or by special agreement or described as having a different time or distance, or listed separately on each new vehicle warranty coverage chart.

### Body Electrical

Coverage includes body wiring harness(es) only.

### Body Structure

Coverage includes compartments and body panels; hinged compartment doors; fire pump closure; body frame and sub-frame, if applicable. *Excludes surface corrosion caused by chips or scratches.*

### Body Structure and Corrosion

Coverage includes compartments and body panels; hinged compartment doors; fire pump closure; body frame and sub-frame, if applicable. *Excludes surface corrosion caused by chips or scratches.*

### Brightwork

Coverage includes all factory-installed components with chrome, polished aluminum, or polished stainless steel surfaces. *Excludes any damage to bumper, backside of bumpers, and concealed or inner surfaces.*

### Cab Corrosion/Perforation

Coverage is limited to rust-through or perforation of the cab and integral sleeper structure and sleeper box (if applicable) due to corrosion from within. *Excludes all conditions of rust or corrosion that has not resulted in rust-through or perforation as well as surface rust or corrosion caused by non-adhesion. Excludes any damage to the paint such as chips or scratches.*

### Cab Structure

Coverage includes cab and integral sleeper structural components, structural components of factory installed sleeper boxes (if applicable), sheet metal panels, doors, and hoods. *Excludes all bolt-on components including door end hood hinges, latches, guides, and other mounting hardware.*

### Corrosion

Coverage provides warranty against corrosion to any metal or metal alloy part of the vehicle. Rust or corrosion to specific components and/or caused by certain conditions are excluded from all Company warranty coverage and will not be paid under Basic Vehicle, Cab Structure, Cab Corrosion, or Aftermarket Parts Warranty.

Exclusions to corrosion warranty include, but are not limited to, the following:

- Corrosion caused by general rust (for example, rust on the unfinished backside of a bumper)
- Surface rust caused by chips or scratches in the paint or chrome surfaces
- Corrosion caused by high-pressure washing, severe wash solutions, cleaning solvents, detergents, compounds
- Corrosion caused by salinity in the environment or corrosive salts and/or chemicals used on the road surface.
- Corrosion caused by acid rain or other industrial fallout
- Corrosion due to improper prevention measures during storage or use

- Corrosion or rust on tone rings, rotors or drums (rotor exclusion does not apply to hydraulic discs with Magna-Coat Rotors)

- Corrosion due to environmental damage (including ocean spray); airborne fallout (includes chemicals, tree sap, etc.), or other atmospheric conditions or other acts of nature

- Corrosion due to improper use, misuse or abuse, negligence, including improper or insufficient maintenance

### Cowl Corrosion/Perforation

Coverage is limited to rust-through or perforation of the cowl due to corrosion from within. *Excludes all conditions of rust or corrosion that have not resulted in rust-through or perforation as well as surface rust or corrosion caused by non-adhesion. Excludes any damage to the paint such as chips or scratches.*

### Cowl Structure

Coverage includes cowl structural components, sheet metal panels, and hood. *Excludes all bolt-on components including hood hinges, latches, guides, or other mounting hardware.*

### Crossmembers

Coverage includes crossmembers, gussets, and huck-mounting bolts that attach gussets to crossmembers and gussets/crossmembers to frame rails. *Excludes any bolt-on item attached with either conventional or huck bolts.*

### Driveline

Coverage includes driveshaft tubing, U-joints, yokes, support bearings, and splines.

### Drivetrain

Coverage includes transmission, (except Allison transmissions) steer axle(s), drive axle(s), and transfer case. *Excludes tag axle(s), pusher axle(s), driveline, and U-joints.*

### Frame Rails

Coverage is limited to breaking or cracking of factory installed frame rails, frame rail liners, frame rail extensions, and any item(s) factory welded to them. *Excludes all bolt-on items regardless if attached with conventional or huck bolts.*

### Glider

An incomplete vehicle which may be ordered with or without engine and/or major drive train components; warranty coverage includes all components as specified in the specific build specification.

### Off Road On-Site Assistance

Coverage is exclusively available for off road vehicles that are prohibited from use on public streets. If this coverage is provided, it will be specifically included in the coverage table as a separate category. Coverage includes on-site assistance and/or equipment transportation to the nearest authorized repairing location for a Daimler Trucks North America LLC warrantable repair.

### Paint (Body, Cab, & Cowl)

Paint coverage excludes lack of gloss issues on vehicles painted with low gloss colors; the underside of hoods and roof and side mounted air linings; and any damages to the paint or painted surface such as chips and scratches.

### Body Paint

Coverage includes all factory-painted exterior body surfaces. Warranted against orange peel; peeling/delaminating; cracking or checking; or loss of gloss due to cracking, checking or hazing.

### Cab Paint

Coverage includes all factory-painted exterior surfaces (except those included in chassis paint coverage). Warranted against orange peel; peeling or delaminating; cracking or checking; or loss of gloss due to cracking, checking or hazing.

### Cowl Paint

Coverage includes all factory-painted exterior surfaces of cowl structure (except those included in chassis paint). Warranted against orange peel; peeling or delaminating; cracking or checking; or loss of gloss due to cracking, checking or hazing.

### Paint, Chassis (Chassis Paint)

Coverage includes all factory painted surfaces on frame rails, crossmembers/gussets, front and rear bumpers, suspension components, power train components, drivelines, fuel tanks, air tanks, wheel end equipment, tool boxes, battery boxes, access steps, and attaching brackets and hardware. Warranted against peeling or non-adhesion. *Excludes U-joints and any damages to the paint or painted surface such as chips and scratches.*

### Towing/Roadside Assistance

Coverage includes roadside assistance or towing (to the nearest authorized repair location) for a Daimler Trucks North America LLC warrantable repair in a vehicle-down situation that prevents the safe and lawful operation of the vehicle. If this coverage is provided, it will be specifically included in the coverage table as a separate category.

### Transfer Case Assembly

Coverage includes housing and all internally lubricated parts.

### Transmission

Coverage includes housing and all internally lubricated parts, electric/air shift/control units, valves, gaskets, and seals. *Excludes broken synchronizer pins, PTOs, transfer case(s), idlines, gauge senders, yoke(s), clutch and clutch control components including clutch brake. Excludes Allison automatic transmissions and Twin Disc Automatic Transmissions.*

### Wheel End Equipment

Coverage includes brake components, wheels, hubs, drums, rotors, wheel seals/ bearings, slack adjusters, and attaching hardware.

# DETROIT™ DD13® ENGINE

FROM  
**350-470**  
Horsepower

FROM  
**1250-1650**  
lb-ft Torque

DISPLACEMENT  
**12.8**  
Liters

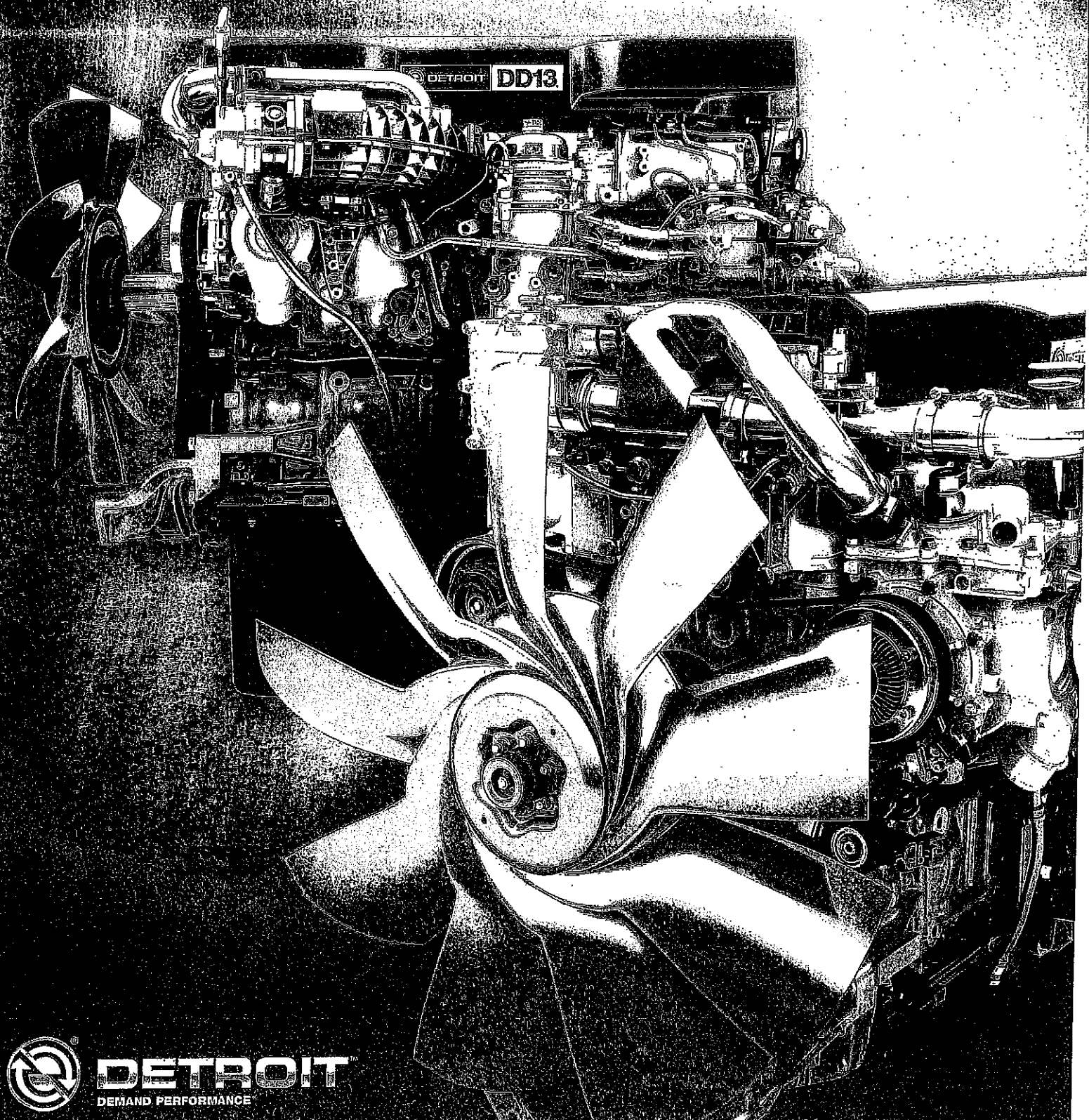

## GETTING YOUR ENGINE SERVICED QUICKLY AND EASILY CAN MAKE A POSITIVE IMPACT ON YOUR TOTAL COST OF OWNERSHIP.

The DD13 can go up to 50,000 miles between oil drain, oil filter and fuel filter changes. That's the longest scheduled maintenance interval in its class. And better yet, it's easy to keep an eye on those important maintenance items like the cartridge style filters, which are conveniently located above the frame rails along with the oil fill. This makes it easy to replace the filters when it's time and to get you back on the road quickly. Also, the fuel filter module has a new two-filter design for simplified serviceability.

When you need genuine parts and expert service, the Detroit support network will get you back on the road fast. The DD13 drives down your cost of ownership at every turn, sharing service procedures and 65% of its parts with the DD15. And you are supported by the network: hundreds of authorized service outlets, an award-winning technician training program, an extensive parts distribution network and expert engine support from our technical support center. Detroit combines all this to give you the genuine parts and expert service you need to succeed.

## FACTORY-BACKED WARRANTY

Detroit engine owners enjoy comprehensive warranty coverage, including a fast, hassle-free process and expedited parts and service for critical downtime situations.

### Standard Warranty

Item	Warranty Limits (Whichever Occurs First)		Repair Charge (Paid by Owner)	
	Months	Miles/ Kilometers	Parts	Labor
Engine	0-24	Unlimited	No charge	No charge
Injectors	0-24	200,000 mi 320,000 km	No charge	No charge
Upon expiration of the 24-month warranty coverage, but within 500,000 mi / 800,000 km of use, the warranty continues to apply as follows:				
Major Components	25-60	500,000 mi 800,000 km	No charge	Not covered

### Maintenance Intervals

Item	Mi./Hr.	Severe Duty	Short-Haul	Long-Haul
Engine Oil and Filter Change*	Miles	25,000	35,000	50,000
	Hours	640	895	1,280
Fuel Filter Change	Miles	25,000	35,000	50,000
	Hours	640	895	1,280
Valve Lash Adjustment	Miles	Adjust at 100,000, at 500,000 and every 500,000 thereafter.		
	Hours	Adjust at 2,565, at 12,825 and every 12,825 thereafter.		
Diesel Particulate Filter	Miles	A check engine light will illuminate when ash requires removal. Normal DPF ash cleaning intervals are 300,000 to 400,000 miles.		
	Hours	A check engine light will illuminate when ash requires removal. Normal DPF ash cleaning intervals are 9,000 to 10,250 hours.		
DEF Pump Filter	Miles	150,000	175,000	250,000
	Hours	3,840	4,475	6,400

\* Based on using the Detroit lube oil and oil analysis program.  
Severe duty is up to 30,000 annual miles and a vehicle that averages less than 5 miles per gallon (mpg).  
Short-haul is between 30,000 and 60,000 annual miles and a vehicle that averages between 5.1 and 5.9 mpg.  
Long-haul is over 60,000 annual miles and a vehicle that averages greater than 6 mpg.  
† Miles/Hours, whichever occurs first.

EXTENDED WARRANTY

DD13<sup>™</sup>/DD15<sup>™</sup>/DD16<sup>™</sup> ENGINES

# EXTENDED WARRANTY

## Extended Service Coverage

DD15

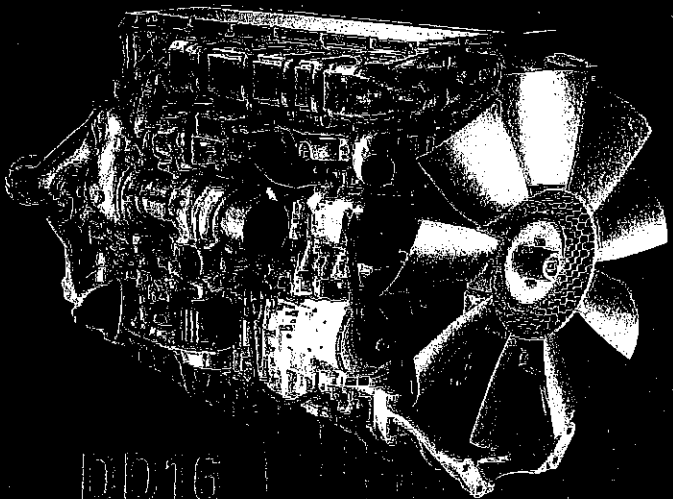
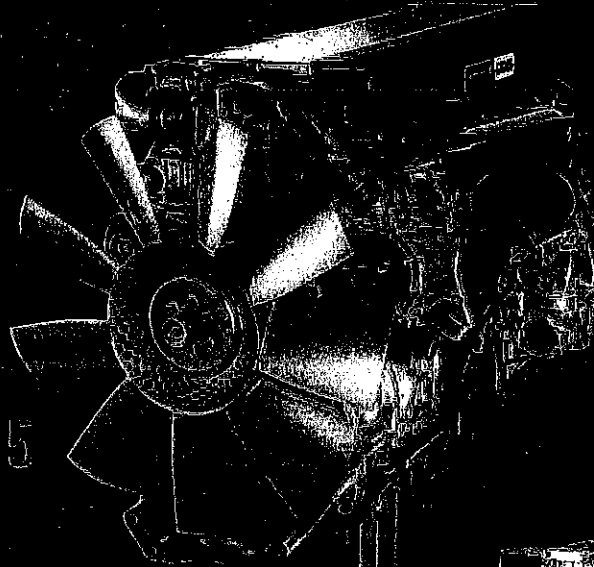

DD16

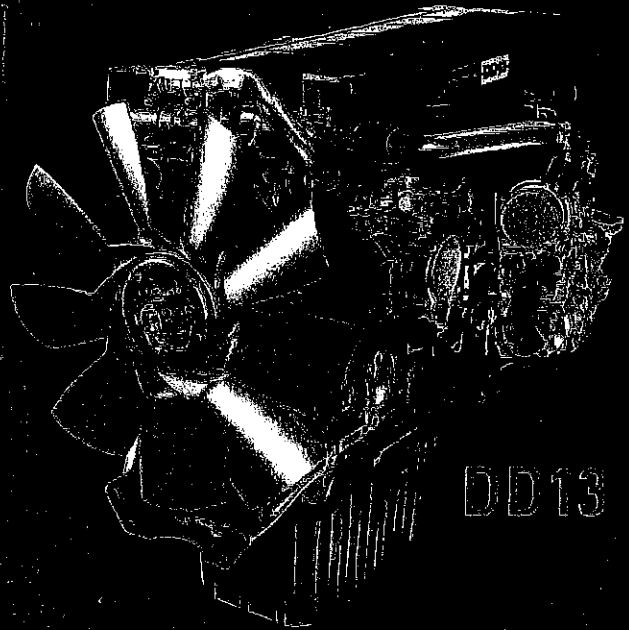

DD13

**DETROIT DIESEL**

DEMAND PERFORMANCE



# ADDED PROTECTION, MILE AFTER MONEY-MAKING MILE.

**Demand the best for your business. Choose Detroit Diesel.**

**Detroit Diesel Extended Warranty is available through your authorized service outlet.**

**Get added protection for vocational or on-highway applications with the plan that works best for you.**

COVERAGE STRUCTURE		
	On-Highway	Vocational
<b>Engine types</b>	DD13 DD15 < 1850 ft. lb. torque DD15 ≥ 1850 ft. lb. torque DD16	DD13 DD15 < 1850 ft. lb. torque DD15 ≥ 1850 ft. lb. torque DD16
<b>Packages</b>	EW1 EW2 EW3 EW4 (available upon request)	EW1 EW2 EW3 EW4 (available upon request)
<b>Year/mile option for total package</b>	3/300,000 3/400,000 3/500,000 4/400,000 4/500,000 5/500,000	5/200,000 7/250,000
<b>Deductible options</b>	Distinct deductible offering \$0 or \$300/visit	
<b>Specialty coverage</b>	Towing (3 years, 4 years or 5 years) Contact the DTNA Extended Warranty group for towing coverage	

## TOUGHEN UP YOUR WARRANTY

Sure, Detroit Diesel's Extended Warranty coverage gives you peace of mind, but that's not all:

- Get complete engine coverage – including aftertreatment
- Enhance resale value by allowing your engine to operate the way it was designed
- Give the vehicle's second owner added value and quality assurance with a transferable warranty
- Protect against future cost increases for parts and labor during the coverage period
- Convenient service locations let you schedule warranty service at more than 800 authorized service facilities. Warranty administration is handled at the factory by OEM.

## FLEXIBLE OPTIONS MAKE PURCHASING EASY

Purchase your extended warranty when you buy your vehicle and roll the cost into the purchase price, or take up to 12 months to decide (late fee waived up to 12 months or \$400 USD between 12-18 months).

# FOUR COVERAGE OPTIONS – WHATEVER YOUR BUSINESS, WE’VE GOT YOU COVERED.

## EW4

### ALL EW3 COMPONENTS PLUS:

AFTERTREATMENT SYSTEM MOUNTING BRACKETS & CLAMPS  
 DIESEL OXIDATION CATALYST & HOUSING  
 DIESEL PARTICULATE FILTER & HOUSING  
 SCR CATALYST & HOUSING

## EW3

### ALL EW2 COMPONENTS PLUS:

AFTERTREATMENT CONTROL MODULE  
 AFTERTREATMENT NOX SENSORS  
 AFTERTREATMENT PRESSURE SENSORS  
 AFTERTREATMENT TEMPERATURE SENSORS  
 AIR COMPRESSOR  
 DEF PUMP/METERING UNIT/INJECTION UNIT

### ELECTRICAL HARNESS & CONNECTORS

ENGINE HARNESS

SEALS

- FRONT & REAR CRANKSHAFT
- THERMOSTAT HOUSING GASKET

WATER PUMP SEAL

## EW2

### ALL EW1 COMPONENTS PLUS:

FUEL INJECTORS  
 TURBO

## EW1

AIR INLET MANIFOLD  
 AIR INTAKE THROTTLE VALVE  
 ALT BRACKET\*  
 BELT TENSIONER  
 CAMSHAFT ASSEMBLY (INC. SEALS)  
 BOLD PIPE ASSEMBLY  
 BORN ROD, BEARINGS & BOLTS  
 CONNECTING ROD BEARINGS  
 COOLER INLET PIPE  
 CRANKCASE BREATHER OIL SEPARATOR  
 CRANKSHAFT THRUST WASHER  
 CYLINDER BLOCK  
 CYLINDER HEAD ASSEMBLY  
 CYLINDER HEAD GASKET  
 CYLINDER LINER  
 EGR SYSTEM  
 ENGINE-MOUNTED SENSORS  
 EXHAUST MANIFOLD & BELLOW  
 FAN SUPPORT ASSEMBLY  
 FLYWHEEL, HOUSING & GASKET  
 FUEL FILTER HOUSING  
 GEAR CASE  
 GEAR TRAIN  
 GEAR TRAIN/TIMING CASE GASKET

HIGH PRESSURE FUEL SYSTEM & LINES  
 HYDRAULIC PUMP\*  
 HYDROCARBON FUEL LINE  
 HYDROCARBON INJECTION VALVE  
 HYDROCARBON METERING UNIT  
 INTEGRATED ENGINE BRAKE  
 LOW PRESSURE FUEL PUMP  
 MAIN BEARINGS  
 MAIN BEARING BOLTS  
 MCM/OPC  
 OIL COOLER, HOUSING & GASKETS  
 OIL PAN & SEALS  
 OIL PRES REG & RELIEF VALVES  
 OIL PUMP  
 PISTONS (RINGS, PINS, RETAINERS)  
 ROCKER ARM ASSEMBLY  
 ROCKER COVER & SEALS  
 THERMOSTAT HOUSING  
 TURBOCHARGER OUTLET ELBOW  
 TURBO COMPOUND DEVICE & COUPLING  
 VALVES (EXHAUST, INTAKE)  
 VALVE SPRINGS, GUIDES, INSERTS  
 VIBRATION DAMPER  
 WATER PUMP, EXCL WATER PUMP SEAL

*Consult your dealer for details of parts covered.*

*\*If supplied by DDB*



## FREQUENTLY ASKED QUESTIONS

Q: Can I roll my Extended Warranty costs into the price of my vehicle?

A: Yes, if you purchase at the time of the vehicle sale. Otherwise, the purchase transaction will be separate.

Q: What should I do if my engine needs repair?

A: Contact any authorized DTNA dealer or Detroit Diesel service outlet.

Q: Is towing included in the Extended Warranty coverage?

A: While towing is part of the standard warranty, additional towing coverage is available for purchase.

Q: Is coverage transferable to future owners?

A: Yes, coverage is transferable for a fee of \$500, and transfer must be registered within 10 days of sale.

## DEMAND SUPPORT, ANYWHERE.

When you need genuine parts and expert service, tap into Detroit Diesel's support network of more than 800 authorized service outlets across North America. We'll get you back on the road. Fast.

- Award-winning technician program
- Unmatched parts availability
- Genuine parts
- Live technical support

To learn more about Detroit Diesel's extended warranty options, visit [DetroitDiesel.com](http://DetroitDiesel.com), call 1-800-332-4410 or contact your nearest authorized service outlet.

**Demand support at [DetroitDiesel.com](http://DetroitDiesel.com).**

**DETROIT DIESEL**

DEMAND PERFORMANCE





# Allison Transmission Coverage

## Effective Dates

Transmission coverage effective dates as shown below are based upon individual agreements entered into between the OEM and Allison.

Navistar	Vehicles built on or after April 11, 2011.
Hino	Vehicles built on or after December 15, 2011.
American LaFrance	Vehicles built on or after January 1, 2012.

All other OEMs referenced on the cover of this guide are eligible to receive Partnership Coverage and Extended Transmission Coverage, so long as they meet the Extended Transmission Coverage requirements listed below.

**NOTE:** Stated prices are effective for Extended Transmission Coverage purchased in 2015.

## Transmission Coverage Definitions And Requirements

### Standard Limited Warranty

All Allison transmissions carry a comprehensive Standard Limited Warranty covering 100% parts and labor. The length of Standard Limited Warranty coverage depends upon the Vocational Model Series and vehicle vocation.

**REQUIREMENTS:** Use of Allison Approved TES 295<sup>®</sup> transmission fluid\*\* and Genuine Allison Filters is required to be eligible for Partnership Transmission Coverage and Extended Transmission Coverage. Failure to use Allison Approved TES 295<sup>®</sup> transmission fluid and Genuine Allison Filters during the Standard Limited Warranty coverage period will result in no additional coverage options beyond Standard Limited Warranty.

### Partnership Coverage

Some Allison-equipped vehicles purchased through Allison Partnerships carry Partnership Coverage. Partnership Coverage begins at the end of the Standard Limited Warranty period. Duration of Partnership Coverage varies depending upon the Vocational Model Series purchased.

**REQUIREMENTS:** Use of Allison Approved TES 295<sup>®</sup> transmission fluid and Genuine Allison Filters is required. Failure to use Allison Approved TES 295<sup>®</sup> transmission fluid and Genuine Allison Filters will result in no coverage for repairs beyond Standard Limited Warranty.

**NOTE:** Except as noted, all transmissions with Partnership Coverage beyond Standard Limited Warranty have 100% parts and labor coverage with no mileage limitations.

### Extended Transmission Coverage\*\*\*

In addition to Partnership Coverage, transmissions purchased through Allison Partnerships are eligible for Extended Transmission Coverage. Extended Transmission Coverage can be purchased on all models to increase coverage to a total of five years. Extended Transmission Coverage can be purchased on Highway Series, P&D/Beverage, to increase coverage to a total of seven years. Extended Transmission Coverage begins at the end of Partnership Coverage and is available for purchase through Allison Authorized Distributors and Dealers.

**REQUIREMENTS:** Use of Allison Approved TES 295<sup>®</sup> transmission fluid\*\* and Genuine Allison Filters is required. Failure to use Allison Approved TES 295<sup>®</sup> transmission fluid and Genuine Allison Filters will result in no coverage for repair beyond the Standard Limited Warranty period. If the transmission is not OEM factory filled with Allison Approved TES 295<sup>®</sup> transmission fluid and Genuine Allison Filters, then Allison Approved TES 295<sup>®</sup> transmission fluid and Genuine Allison Filters must be installed at the time of Extended Transmission Coverage purchase. Transmissions not OEM factory filled with Allison Approved TES 295<sup>®</sup> transmission fluid, or transmissions operating with non-TES 295<sup>®</sup> fluids, must be drained and filled with Allison Approved TES 295<sup>®</sup> transmission fluid to achieve 100% concentration. One hundred percent concentration is not achieved until the second consecutive fluid change using Allison Approved TES 295<sup>®</sup> transmission fluid. The second consecutive change must be achieved at the time of Extended Transmission Coverage purchase.

\* Suggested retail prices are established for each transmission vocational model/vocation combination. Prices and/or coverage are subject to change without notice. For current prices and coverage information, go to [allisontransmission.com](http://allisontransmission.com).

\*\* For a list of current Allison Approved TES 295<sup>®</sup> transmission fluids, go to: [allisontransmission.com](http://allisontransmission.com); click on Parts + Service, then Approved Fluids.

\*\*\* The terms and conditions under which Allison Transmission offers Extended Transmission Coverage are set forth on the back of the Extended Transmission Coverage Agreement Registration, available from any authorized Allison Transmission Distributor or Dealer.

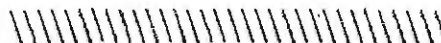

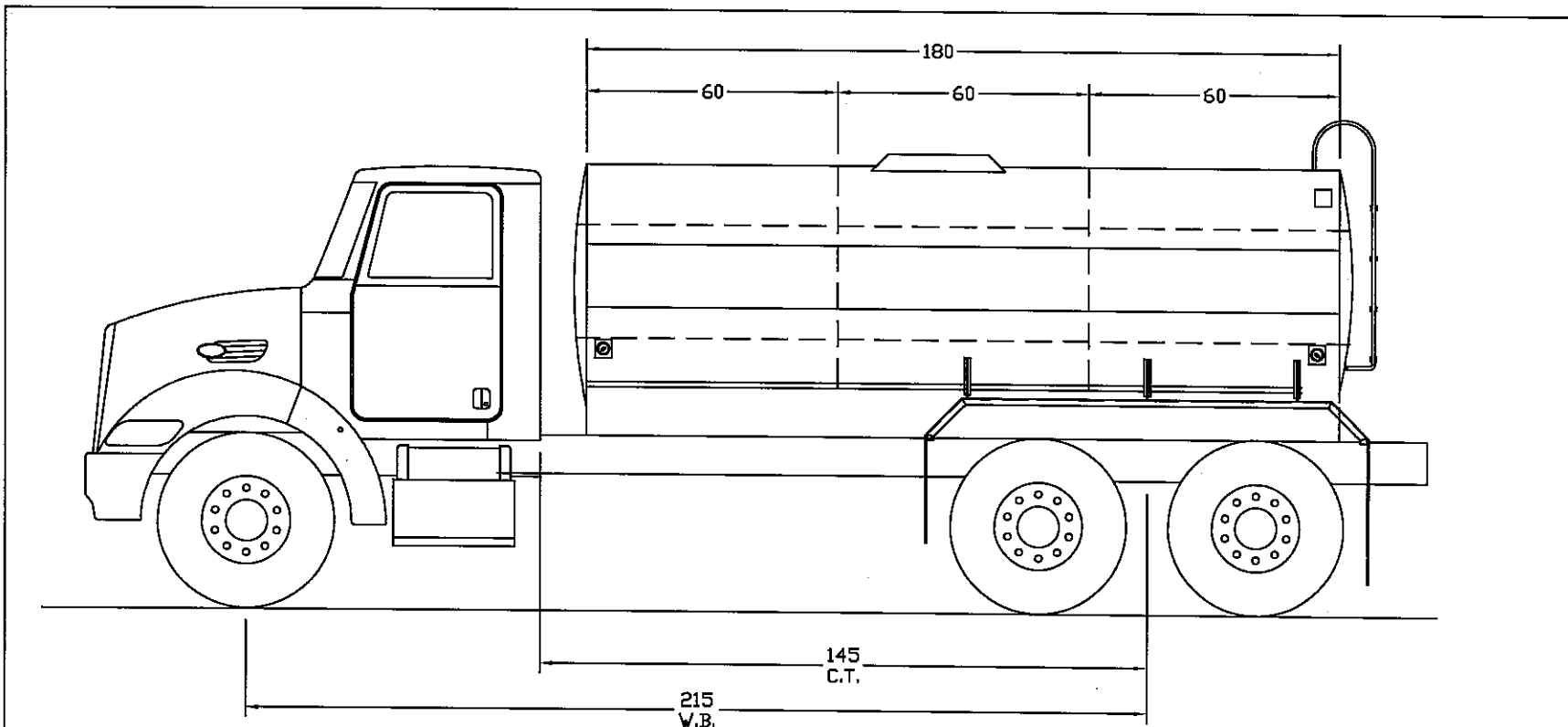

	CHASSIS	STEEL	LIQUID	TOTALS
F	10913	1289	0	12202
R	7976	4386	0	12362
T	18889	5675	0	24564

WEIGHT ESTIMATES ARE PRELIMINARY. FINAL ESTIMATES TO BE PROVIDED ON RECEIPT OF CHASSIS.

				4000 GALLON 15 FT - DRIVER'S SIDE VIEW		
REV.	DATE	E.C.N. NO.	BY	SCALE: 1/2"=1'	SHEET 1 OF 2	DWN: ACS
-- WARNING --				DATE: 10-29-15		
UNAUTHORIZED USE, REPRODUCTION OR MANUFACTURE IN WHOLE OR IN PART IS PROHIBITED. DRAWING, DESIGN, AND OTHER DISCLOSURES ARE PROPERTY OF I.T.B. INC.				INTERSTATE TRUCK BODIES, INC		
				UNIT(S)	SAVED AS: 4K 15FT WT CALC	DRAWING NO.

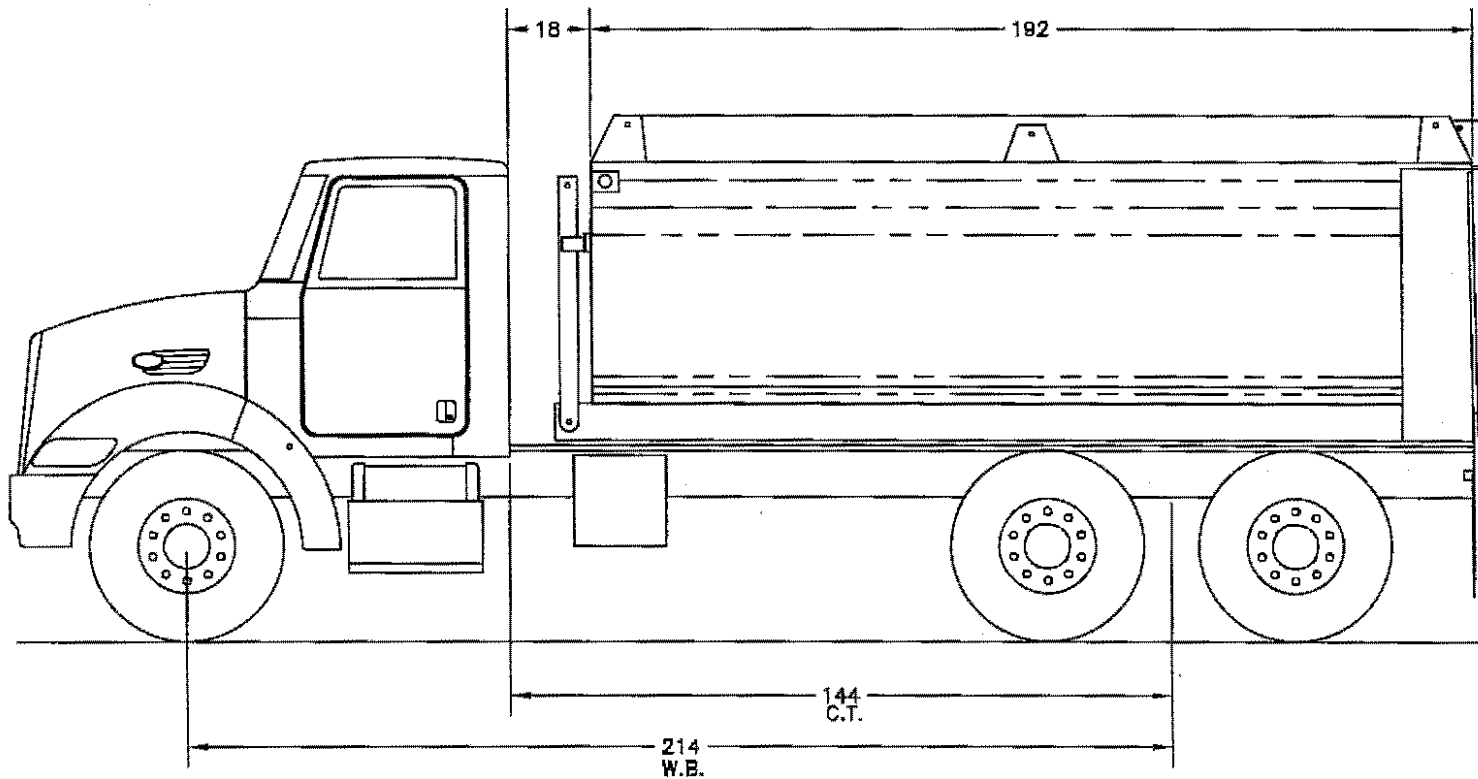

	CHASSIS	STEEL	LOAD	TOTALS
F	10853	1484	3364	15701
R	7976	5410	20634	34020
T	18829	6894	23998	49721

WEIGHT ESTIMATES ARE PRELIMINARY. FINAL ESTIMATES TO BE PROVIDED ON RECEIPT OF CHASSIS.

REV.	DATE	E.C.N. NO.	BY
<b>-- WARNING --</b>			
UNAUTHORIZED USE, REPRODUCTION OR MANUFACTURE IN WHOLE OR IN PART IS PROHIBITED. DRAWING, DESIGN, AND OTHER DISCLOSURES ARE PROPERTY OF I.T.B. INC.			

16' DUMP BODY WT CALC DRIVER'S SIDE VIEW		
 <b>INTERSTATE</b> Truck Bodies, Inc.		DWN: ACS
		DATE: 9-21-16
UNIT(S)		SCALE: 1/2"=1'
SAVED AS: 16' DUMP WT CALC		DRAWING NO.

Prepared for:  
 Bob Charleton  
 Pima County  
 1291 S Mission Road  
 Tucson, AZ 85713  
 Phone: 520-724-2614

Prepared by:  
 Cory Thompson  
 FREIGHTLINER OF ARIZONA  
 9899 W ROOSEVELT STREET  
 TOLLESON, AZ 85353

# Dump Truck

## SPECIFICATION PROPOSAL

Data Code	Description	Weight Front	Weight Rear
<b>Price Level</b>			
PRL-14D	SD PRL-14D (EFF:10/05/15)		
<b>Data Version</b>			
DRL-042	SPECPRO21 DATA RELEASE VER 042		
<b>Vehicle Configuration</b>			
001-177	114SD CONVENTIONAL CHASSIS	7,934	6,576
004-217	2017 MODEL YEAR SPECIFIED		
002-004	SET BACK AXLE - TRUCK	480	-480
019-001	TRAILER TOWING PROVISION AT END OF FRAME FOR TRUCK	10	10
003-001	LH PRIMARY STEERING LOCATION		
<b>General Service</b>			
AA1-003	TRUCK/TRAILER CONFIGURATION		
AA6-001	DOMICILED, USA 50 STATES (INCLUDING CALIFORNIA AND CARB OPT-IN STATES)		
A85-011	CONSTRUCTION SERVICE		
A84-1GM	GOVERNMENT BUSINESS SEGMENT		
AA4-003	DRY BULK COMMODITY		
AA5-006	TERRAIN/DUTY: 10% (SOME) OF THE TIME, IN TRANSIT, IS SPENT ON NON-PAVED ROADS		
AB1-008	MAXIMUM 8% EXPECTED GRADE		
AB5-003	MAINTAINED GRAVEL OR CRUSHED ROCK - MOST SEVERE IN-TRANSIT (BETWEEN SITES) ROAD SURFACE		
995-1AE	FREIGHTLINER LEVEL II WARRANTY		
A66-99D	EXPECTED FRONT AXLE(S) LOAD : 18000.0 lbs		
A68-99D	EXPECTED REAR DRIVE AXLE(S) LOAD : 40000.0 lbs		
A63-99D	EXPECTED GROSS VEHICLE WEIGHT CAPACITY : 58000.0 lbs		



Prepared for:  
 Bob Charleton  
 Pima County  
 1291 S Mission Road  
 Tucson, AZ 85713  
 Phone: 520-724-2614

Prepared by:  
 Cory Thompson  
 FREIGHTLINER OF ARIZONA  
 9899 W ROOSEVELT STREET  
 TOLLESON, AZ 85353

Data Code	Description	Weight Front	Weight Rear
A70-99D	EXPECTED GROSS COMBINATION WEIGHT : 80000.0 lbs		
<b>Truck Service</b>			
AA3-004	END DUMP BODY		
AF4-99D	EXPECTED EMPTY BODY WEIGHT : 0.0 lbs		
<b>Tractor Service</b>			
AA2-005	FLATBED TRAILER		
AH6-001	SINGLE (1) TRAILER		
<b>Engine</b>			
101-2X9	DETROIT DD13 12.8L 450 HP @ 1625 RPM, 1900 GOV RPM, 1550 LB/FT @ 975 RPM		
<b>Electronic Parameters</b>			
79A-078	78 MPH ROAD SPEED LIMIT		
79B-000	CRUISE CONTROL SPEED LIMIT SAME AS ROAD SPEED LIMIT		
79G-006	5 MINUTES IDLE SHUTDOWN WITH CLUTCH AND SERVICE BRAKE OVERRIDE		
79K-007	PTO MODE ENGINE RPM LIMIT - 1100 RPM		
79M-002	PTO MODE BRAKE OVERRIDE - SERVICE BRAKE APPLIED OR PARK BRAKE NOT APPLIED		
79P-002	PTO RPM WITH CRUISE SET SWITCH - 700 RPM		
79Q-003	PTO RPM WITH CRUISE RESUME SWITCH - 800 RPM		
79S-001	PTO MODE CANCEL VEHICLE SPEED - 5 MPH		
79U-007	PTO GOVERNOR RAMP RATE - 250 RPM PER SECOND		
79W-001	ONE REMOTE PTO SPEED		
79X-005	REMOTE PTO SPEED 1 SETTING - 900 RPM		
80D-001	SOFT CRUISE CONTROL ENABLED		
80G-001	PTO MINIMUM RPM - 600		
<b>Engine Equipment</b>			
99C-017	2016 ONBOARD DIAGNOSTICS/2010 EPA/CARB/FINAL GHG17 CONFIGURATION		
99D-011	2008 CARB EMISSION CERTIFICATION - CLEAN IDLE (INCLUDES 6X4 INCH LABEL ON LOWER FORWARD CORNER OF DRIVER DOOR)		
PMT-998	NO 2013 ENGINE ESCALATOR		
13E-001	STANDARD OIL PAN		
105-001	ENGINE MOUNTED OIL CHECK AND FILL		



Prepared for:  
 Bob Charleton  
 Pima County  
 1291 S Mission Road  
 Tucson, AZ 85713  
 Phone: 520-724-2614

Prepared by:  
 Cory Thompson  
 FREIGHTLINER OF ARIZONA  
 9899 W ROOSEVELT STREET  
 TOLLESON, AZ 85353

Data Code	Description	Weight Front	Weight Rear
014-1B5	SIDE OF HOOD AIR INTAKE WITH DONALDSON HIGH CAPACITY AIR CLEANER WITH SAFETY ELEMENT, FIREWALL MOUNTED		
124-1E4	LN 12V 160 AMP LONG BRUSH 2243GH PAD MOUNT ALTERNATOR WITH REMOTE BATTERY VOLT SENSE, LAMP TERMINAL AND HEX SHAFT	10	
292-071	(3) ALLIANCE MODEL 1231, GROUP 31, 12 VOLT MAINTENANCE FREE 3375 CCA THREADED STUD BATTERIES		
290-1CD	BATTERY BOX WITH ALUMINUM COVER MOUNTED SHORT SIDE TO RAIL	15	
281-001	STANDARD BATTERY JUMPERS		
282-003	SINGLE BATTERY BOX FRAME MOUNTED LH SIDE BACK OF CAB		
291-017	WIRE GROUND RETURN FOR BATTERY CABLES WITH ADDITIONAL FRAME GROUND RETURN		
289-001	NON-POLISHED BATTERY BOX COVER		
295-029	POSITIVE AND NEGATIVE POSTS FOR JUMPSTART LOCATED ON FRAME NEXT TO STARTER	2	
107-044	BW MODEL BA-921 19.0 CFM SINGLE CYLINDER AIR COMPRESSOR WITH SAFETY VALVE		
152-041	ELECTRONIC ENGINE INTEGRAL SHUTDOWN PROTECTION SYSTEM		
128-002	JACOBS COMPRESSION BRAKE		
016-1C2	RH OUTBOARD UNDER STEP MOUNTED HORIZONTAL AFTERTREATMENT SYSTEM ASSEMBLY WITH RH B-PILLAR MOUNTED VERTICAL TAILPIPE	30	25
28F-002	ENGINE AFTERTREATMENT DEVICE, AUTOMATIC OVER THE ROAD REGENERATION AND DASH MOUNTED REGENERATION REQUEST SWITCH		
239-026	10 FOOT 06 INCH (126 INCH+0/-5.9 INCH) EXHAUST SYSTEM HEIGHT		
237-1CR	RH CURVED VERTICAL TAILPIPE B-PILLAR MOUNTED ROUTED FROM STEP		
23U-001	6 GALLON DIESEL EXHAUST FLUID TANK	-35	-10
30N-003	100 PERCENT DIESEL EXHAUST FLUID FILL		
23Y-002	DIESEL EXHAUST FLUID PUMP MOUNTED AFT OF DIESEL EXHAUST FLUID TANK		
43X-002	LH MEDIUM DUTY STANDARD DIESEL EXHAUST FLUID TANK LOCATION		
43Y-001	STANDARD DIESEL EXHAUST FLUID TANK CAP		
242-011	ALUMINUM AFTERTREATMENT DEVICE/MUFFLER/TAILOPIPE SHIELD(S)		



Prepared for:  
 Bob Charleton  
 Pima County  
 1291 S Mission Road  
 Tucson, AZ 85713  
 Phone: 520-724-2614

Prepared by:  
 Cory Thompson  
 FREIGHTLINER OF ARIZONA  
 9899 W ROOSEVELT STREET  
 TOLLESON, AZ 85353

Data Code	Description	Weight Front	Weight Rear
273-036	BORG WARNER (KYSOR) REAR AIR ON/OFF ENGINE FAN CLUTCH		
276-001	AUTOMATIC FAN CONTROL WITHOUT DASH SWITCH, NON ENGINE MOUNTED		
110-068	DDC SUPPLIED ENGINE MOUNTED FUEL FILTER/FUEL WATER SEPARATOR WITH WATER-IN-FUEL INDICATOR		
118-001	FULL FLOW OIL FILTER		
266-057	1500 SQUARE INCH ALUMINUM RADIATOR		
103-039	ANTIFREEZE TO -34F, OAT (NITRITE AND SILICATE FREE) EXTENDED LIFE COOLANT		
171-007	GATES BLUE STRIPE COOLANT HOSES OR EQUIVALENT		
172-001	CONSTANT TENSION HOSE CLAMPS FOR COOLANT HOSES		
270-023	HDEP FIXED RATIO COOLANT PUMP AND RADIATOR DRAIN VALVE		
155-074	DELCO 12V MOD 3.175-39MT+ OCP STARTER WITH THERMAL PROTECTION AND INTEGRATED MAGNETIC SWITCH		

**Transmission**

342-1M3	ALLISON 4500 RDS AUTOMATIC TRANSMISSION WITH PTO PROVISION	260	100
---------	--	-----	-----

**Transmission Equipment**

343-339	ALLISON VOCATIONAL PACKAGE 223 - AVAILABLE ON 3000/4000 PRODUCT FAMILIES WITH VOCATIONAL MODELS RDS, HS, MH AND TRV		
84B-012	ALLISON VOCATIONAL RATING FOR ON/OFF HIGHWAY APPLICATIONS AVAILABLE WITH ALL PRODUCT FAMILIES		
84C-023	PRIMARY MODE GEARS, LOWEST GEAR 1, START GEAR 1, HIGHEST GEAR 6, AVAILABLE FOR 3000/4000 PRODUCT FAMILIES ONLY		
84D-023	SECONDARY MODE GEARS, LOWEST GEAR 1, START GEAR 1, HIGHEST GEAR 6, AVAILABLE FOR 3000/4000 PRODUCT FAMILIES ONLY		
84E-000	PRIMARY SHIFT SCHEDULE RECOMMENDED BY DTNA AND ALLISON, THIS DEFINED BY ENGINE AND VOCATIONAL USAGE		
84F-000	SECONDARY SHIFT SCHEDULE RECOMMENDED BY DTNA AND ALLISON, THIS DEFINED BY ENGINE AND VOCATIONAL USAGE		
84G-000	PRIMARY SHIFT SPEED RECOMMENDED BY DTNA AND ALLISON, THIS DEFINED BY ENGINE AND VOCATIONAL USAGE		



Prepared for:  
 Bob Charleton  
 Pima County  
 1291 S Mission Road  
 Tucson, AZ 85713  
 Phone: 520-724-2614

Prepared by:  
 Cory Thompson  
 FREIGHTLINER OF ARIZONA  
 9899 W ROOSEVELT STREET  
 TOLLESON, AZ 85353

Data Code	Description	Weight Front	Weight Rear
84H-000	SECONDARY SHIFT SPEED RECOMMENDED BY DTNA AND ALLISON, THIS DEFINED BY ENGINE AND VOCATIONAL USAGE		
84L-000	LOAD BASED SHIFT SCHEDULE AND VEHICLE ACCELERATION CONTROL RECOMMENDED BY DTNA AND ALLISON, THIS DEFINED VOCATIONAL USAGE		
84U-000	DRIVER SWITCH INPUT - DEFAULT - NO SWITCHES		
34C-002	ELECTRONIC TRANSMISSION CUSTOMER ACCESS CONNECTOR MOUNTED BACK OF CAB		
362-157	CUSTOMER INSTALLED MUNCIE CS20/CS24 SERIES PTO		
363-001	PTO MOUNTING, LH SIDE OF MAIN TRANSMISSION		
341-018	MAGNETIC PLUGS, ENGINE DRAIN, TRANSMISSION DRAIN, AXLE(S) FILL AND DRAIN		
345-003	PUSH BUTTON ELECTRONIC SHIFT CONTROL, DASH MOUNTED		
97G-004	TRANSMISSION PROGNOSTICS - ENABLED 2013		
370-011	WATER TO OIL TRANSMISSION COOLER, FRAME MOUNTED		
346-003	TRANSMISSION OIL CHECK AND FILL WITH ELECTRONIC OIL LEVEL CHECK		
35T-001	SYNTHETIC TRANSMISSION FLUID (TES-295 COMPLIANT)		

Front Axle and Equipment			
400-1BA	DETROIT DA-F-18.0-5 18,000# FL1 71.0 KPI/3.74 DROP SINGLE FRONT AXLE	210	
402-030	MERITOR 16.5X6 Q+ CAST SPIDER CAM FRONT BRAKES, DOUBLE ANCHOR, FABRICATED SHOES	10	
403-002	NON-ASBESTOS FRONT BRAKE LINING		
419-023	CONMET CAST IRON FRONT BRAKE DRUMS		
427-001	FRONT BRAKE DUST SHIELDS	5	
409-021	SKF SCOTSEAL PLUS XL FRONT OIL SEALS		
408-001	VENTED FRONT HUB CAPS WITH WINDOW, CENTER AND SIDE PLUGS - OIL		
416-022	STANDARD SPINDLE NUTS FOR ALL AXLES		
405-002	MERITOR AUTOMATIC FRONT SLACK ADJUSTERS		
406-001	STANDARD KING PIN BUSHINGS		
536-012	TRW TAS-85 POWER STEERING	40	
539-003	POWER STEERING PUMP		





Prepared for:  
 Bob Charleton  
 Pima County  
 1291 S Mission Road  
 Tucson, AZ 85713  
 Phone: 520-724-2614

Prepared by:  
 Cory Thompson  
 FREIGHTLINER OF ARIZONA  
 9899 W ROOSEVELT STREET  
 TOLLESON, AZ 85353

Data Code	Description	Weight Front	Weight Rear
534-003	4 QUART POWER STEERING RESERVOIR	5	
40T-001	ORGANIC SAE 80/90 FRONT AXLE LUBE		
<b>Front Suspension</b>			
620-013	18,000# TAPERLEAF FRONT SUSPENSION	200	
619-005	MAINTENANCE FREE RUBBER BUSHINGS - FRONT SUSPENSION		
410-001	FRONT SHOCK ABSORBERS		
<b>Rear Axle and Equipment</b>			
420-1K4	MT-40-14XP 40,000# R-SERIES TANDEM REAR AXLE		-30
421-433	4.33 REAR AXLE RATIO		
424-003	IRON REAR AXLE CARRIER WITH OPTIONAL HEAVY DUTY AXLE HOUSING		40
386-075	MXL 18T MERITOR EXTENDED LUBE MAIN DRIVELINE WITH HALF ROUND YOKES	60	60
388-073	MXL 17T MERITOR EXTENDED LUBE INTERAXLE DRIVELINE WITH HALF ROUND YOKES		
452-005	DRIVER CONTROLLED TRACTION DIFFERENTIAL - REAR MOST TANDEM/TRIDEM REAR AXLE		20
878-021	(1) INTERAXLE LOCK VALVE AND (1) DRIVER CONTROLLED DIFFERENTIAL LOCK REAR-REAR AXLE VALVE		
87A-001	BLINKING LAMP WITH EACH INTERAXLE LOCK SWITCH, INTERAXLE UNLOCK DEFAULT WITH IGNITION OFF		
87B-004	BLINKING LAMP WITH EACH MODE SWITCH, DIFFERENTIAL UNLOCK WITH IGNITION OFF, ACTIVE <5 MPH		
423-020	MERITOR 16.5X7 Q+ CAST SPIDER CAM REAR BRAKES, DOUBLE ANCHOR, FABRICATED SHOES		
433-002	NON-ASBESTOS REAR BRAKE LINING		
434-019	ASPHALT SPREADER CLEARANCE REAR BRAKE GEOMETRY		
451-023	CONMET CAST IRON REAR BRAKE DRUMS		
440-021	SKF SCOTSEAL PLUS XL REAR OIL SEALS		
426-075	HALDEX GOLDSEAL LONGSTROKE 2-DRIVE AXLES SPRING PARKING CHAMBERS		
428-003	HALDEX AUTOMATIC REAR SLACK ADJUSTERS		
41T-001	ORGANIC SAE 80/90 REAR AXLE LUBE		
42T-001	STANDARD REAR AXLE BREATHER(S)		
<b>Rear Suspension</b>			



Prepared for:  
 Bob Charleton  
 Pima County  
 1291 S Mission Road  
 Tucson, AZ 85713  
 Phone: 520-724-2614

Prepared by:  
 Cory Thompson  
 FREIGHTLINER OF ARIZONA  
 9899 W ROOSEVELT STREET  
 TOLLESON, AZ 85353

Data Code	Description	Weight Front	Weight Rear
622-241	HENDRICKSON HN402 @40,000# REAR SUSPENSION		430
621-035	HENDRICKSON HN 400/460 - 9.56 INCH RIDE HEIGHT		
431-001	STANDARD AXLE SEATS IN AXLE CLAMP GROUP		
624-011	52 INCH AXLE SPACING		
628-010	HENDRICKSON HN, HAULMAAX AND ULTIMAAX SERIES STEEL BEAMS WITH BAR PIN		
623-006	FORE/AFT AND TRANSVERSE CONTROL RODS		100
439-002	REAR SHOCK ABSORBERS - TWO AXLES (TANDEM)		

**Brake System**

490-100	WABCO 4S/4M ABS WITHOUT TRACTION CONTROL
871-001	REINFORCED NYLON, FABRIC BRAID AND WIRE BRAID CHASSIS AIR LINES
904-001	FIBER BRAID PARKING BRAKE HOSE
412-001	STANDARD BRAKE SYSTEM VALVES
46D-002	STANDARD AIR SYSTEM PRESSURE PROTECTION SYSTEM
413-002	STD U.S. FRONT BRAKE VALVE
432-003	RELAY VALVE WITH 5-8 PSI CRACK PRESSURE, NO REAR PROPORTIONING VALVE
480-083	WABCO SS-1200 PLUS AIR DRYER WITH INTEGRAL AIR GOVERNOR AND HEATER
483-004	WABCO OIL COALESCING FILTER FOR AIR DRYER
479-006	AIR DRYER MOUNTED OUTBOARD ON RH RAIL
460-001	STEEL AIR BRAKE RESERVOIRS
477-006	BW DV-2 AUTO DRAIN VALVE WITHOUT HEATER ON ALL TANK(S)

**Trailer Connections**

914-001	AIR CONNECTIONS TO END OF FRAME WITH GLAD HANDS FOR TRUCK AND NO DUST COVERS
296-010	PRIMARY CONNECTOR/RECEPTACLE WIRED FOR SEPARATE STOP/TURN, ABS CENTER PIN POWERED THROUGH IGNITION
297-001	SAE J560 7-WAY PRIMARY TRAILER CABLE RECEPTACLE MOUNTED END OF FRAME
335-004	UPGRADED CHASSIS MULTIPLEXING UNIT

**Wheelbase & Frame**



Prepared for:  
 Bob Charleton  
 Pima County  
 1291 S Mission Road  
 Tucson, AZ 85713  
 Phone: 520-724-2614

Prepared by:  
 Cory Thompson  
 FREIGHTLINER OF ARIZONA  
 9899 W ROOSEVELT STREET  
 TOLLESON, AZ 85353

Data Code	Description	Weight Front	Weight Rear
545-542	5425MM (214 INCH) WHEELBASE		
546-101	11/32X3-1/2X10-15/16 INCH STEEL FRAME (8.73MMX277.8MM/0.344X10.94 INCH) 120KSI	160	50
547-001	1/4 INCH (6.35MM) C-CHANNEL INNER FRAME REINFORCEMENT	200	390
552-056	2325MM (92 INCH) REAR FRAME OVERHANG		
55W-009	FRAME OVERHANG RANGE: 91 INCH TO 100 INCH	-60	260
AC8-99D	CALC'D BACK OF CAB TO REAR SUSP C/L (CA) : 148.45 in		
AE8-99D	CALCULATED EFFECTIVE BACK OF CAB TO REAR SUSPENSION C/L (CA) : 145.45 in		
AE4-99D	CALC'D FRAME LENGTH - OVERALL : 336.12		
AM6-99D	CALC'D SPACE AVAILABLE FOR DECKPLATE : 148.45 in		
FSS-0LH	CALCULATED FRAME SPACE LH SIDE : 54.48 in		
FSS-0RH	CALCULATED FRAME SPACE RH SIDE : 102.42 in		
553-001	SQUARE END OF FRAME		
550-001	FRONT CLOSING CROSSMEMBER		
559-001	STANDARD WEIGHT ENGINE CROSSMEMBER		
562-001	STANDARD MIDSHIP #1 CROSSMEMBER(S)		
572-001	STANDARD REARMOST CROSSMEMBER		
565-002	HEAVY DUTY SUSPENSION CROSSMEMBER		30
<b>Chassis Equipment</b>			
556-1E5	14 INCH PAINTED STEEL BUMPER	20	
558-033	REMOVABLE FRONT TOW HOOKS STORED ON THE CHASSIS FRAME	25	
551-007	GRADE 8 THREADED HEX HEADED FRAME FASTENERS		
<b>Fuel Tanks</b>			
204-156	100 GALLON/378 LITER ALUMINUM FUEL TANK - LH	20	
218-006	25 INCH DIAMETER FUEL TANK(S)		
215-005	PLAIN ALUMINUM/PAINTED STEEL FUEL/HYDRAULIC TANK(S) WITH PAINTED BANDS		
212-007	FUEL TANK(S) FORWARD		
664-001	PLAIN STEP FINISH		
205-001	FUEL TANK CAP(S)		
122-1F1	DAVCO 482 FUEL/WATER SEPARATOR	10	
216-020	EQUIFLO INBOARD FUEL SYSTEM		



Prepared for:  
 Bob Charleton  
 Pima County  
 1291 S Mission Road  
 Tucson, AZ 85713  
 Phone: 520-724-2614

Prepared by:  
 Cory Thompson  
 FREIGHTLINER OF ARIZONA  
 9899 W ROOSEVELT STREET  
 TOLLESON, AZ 85353

Data Code	Description	Weight Front	Weight Rear
202-016	HIGH TEMPERATURE REINFORCED NYLON FUEL LINE		
<b>Tires</b>			
093-1RJ	MICHELIN X WORKS Z 315/80R22.5 20 PLY RADIAL FRONT TIRES	100	
094-0DJ	MICHELIN XDE M/S 11R22.5 16 PLY RADIAL REAR TIRES		88
<b>Hubs</b>			
418-056	CONMET PRESET PLUS IRON FRONT HUBS		
450-056	CONMET PRESET PLUS IRON REAR HUBS		
<b>Wheels</b>			
502-433	ACCURIDE 29039 22.5X9.00 10-HUB PILOT 5.25 INSET 5-HAND STEEL DISC FRONT WHEELS	66	
505-524	MAXION WHEELS 90541 22.5X8.25 10-HUB PILOT 2-HAND STEEL DISC REAR WHEELS		
<b>Cab Exterior</b>			
829-1A2	114 INCH BBC FLAT ROOF ALUMINUM CONVENTIONAL CAB		
650-008	AIR CAB MOUNTS		
648-002	NONREMOVABLE BUGSCREEN MOUNTED BEHIND GRILLE		
667-004	FRONT FENDERS SET-BACK AXLE		
678-001	LH AND RH GRAB HANDLES		
646-041	STATIONARY BLACK GRILLE		
65X-004	BLACK HOOD MOUNTED AIR INTAKE GRILLE		
644-004	FIBERGLASS HOOD		
727-1AJ	DUAL 14 INCH ROUND POLISHED AIR HORNS	4	
726-001	SINGLE ELECTRIC HORN		
728-002	DUAL HORN SHIELDS		
657-1CV	DOOR LOCKS AND IGNITION SWITCH KEYED THE SAME WITH (4) KEYS		
575-001	REAR LICENSE PLATE MOUNT END OF FRAME		
312-068	HALOGEN COMPOSITE HEADLAMPS WITH BLACK BEZELS		
302-001	(5) AMBER MARKER LIGHTS		
294-001	INTEGRAL STOP/TAIL/BACKUP LIGHTS		
300-015	STANDARD FRONT TURN SIGNAL LAMPS		
744-1BH	DUAL WEST COAST MOLDED-IN COLOR MIRRORS		
797-001	DOOR MOUNTED MIRRORS		
796-001	102 INCH EQUIPMENT WIDTH		



Prepared for:  
 Bob Charleton  
 Pima County  
 1291 S Mission Road  
 Tucson, AZ 85713  
 Phone: 520-724-2614

Prepared by:  
 Cory Thompson  
 FREIGHTLINER OF ARIZONA  
 9899 W ROOSEVELT STREET  
 TOLLESON, AZ 85353

Data Code	Description	Weight Front	Weight Rear
743-1AP	LH AND RH 8 INCH MOLDED-IN COLOR CONVEX MIRRORS MOUNTED UNDER PRIMARY MIRRORS		
74A-001	RH DOWN VIEW MIRROR		
729-001	STANDARD SIDE/REAR REFLECTORS		
677-053	RH AFTERTREATMENT SYSTEM CAB ACCESS WITH STEEL SHIELDING		
768-043	63X14 INCH TINTED REAR WINDOW		
661-003	TINTED DOOR GLASS LH AND RH WITH TINTED NON-OPERATING WING WINDOWS		
654-003	MANUAL DOOR WINDOW REGULATORS		
663-013	TINTED WINDSHIELD		
659-019	2 GALLON WINDSHIELD WASHER RESERVOIR WITHOUT FLUID LEVEL INDICATOR, FRAME MOUNTED		

**Cab Interior**

707-1AK	OPAL GRAY VINYL INTERIOR		
706-013	MOLDED PLASTIC DOOR PANEL		
708-013	MOLDED PLASTIC DOOR PANEL		
772-006	BLACK MATS WITH SINGLE INSULATION		
691-008	FORWARD ROOF MOUNTED CONSOLE WITH UPPER STORAGE COMPARTMENTS WITHOUT NETTING		
694-010	IN DASH STORAGE BIN		
742-007	(2) CUP HOLDERS LH AND RH DASH		
680-006	GRAY/CHARCOAL FLAT DASH		
720-003	5 LB. FIRE EXTINGUISHER	10	
700-002	HEATER, DEFROSTER AND AIR CONDITIONER		
701-001	STANDARD HVAC DUCTING		
703-005	MAIN HVAC CONTROLS WITH RECIRCULATION SWITCH		
170-015	STANDARD HEATER PLUMBING		
130-033	DENSO HEAVY DUTY AIR CONDITIONER COMPRESSOR		
702-002	BINARY CONTROL, R-134A		
739-033	STANDARD INSULATION		
285-013	SOLID-STATE CIRCUIT PROTECTION AND FUSES		
280-007	12V NEGATIVE GROUND ELECTRICAL SYSTEM		
324-014	DOMELIGHT WITH 3-WAY SWITCH ACTIVATED BY LH AND RH DOORS		
655-001	CAB DOOR LATCHES WITH MANUAL DOOR LOCKS		



Prepared for:  
 Bob Charleton  
 Pima County  
 1291 S Mission Road  
 Tucson, AZ 85713  
 Phone: 520-724-2614

Prepared by:  
 Cory Thompson  
 FREIGHTLINER OF ARIZONA  
 9899 W ROOSEVELT STREET  
 TOLLESON, AZ 85353

Data Code	Description	Weight Front	Weight Rear
284-045	(2) 12 VOLT POWER RECEPTACLES MOUNTED IN DASH		
722-002	TRIANGULAR REFLECTORS WITHOUT FLARES	10	
756-1D9	PREMIUM HIGH BACK AIR SUSPENSION DRIVER SEAT WITH 3 CHAMBER AIR LUMBAR, INTEGRATED CUSHION EXTENSION, FORWARD AND REAR CUSHION TILT, ADJUSTABLE SHOCK ABSORBER	70	
760-1DC	BASIC HIGH BACK NON SUSPENSION PASSENGER SEAT		
711-004	LH AND RH INTEGRAL DOOR PANEL ARMRESTS		
758-033	VINYL WITH CLOTH INSERT DRIVER SEAT		
761-033	VINYL WITH CLOTH INSERT PASSENGER SEAT		
763-101	BLACK SEAT BELTS		
532-002	ADJUSTABLE TILT AND TELESCOPING STEERING COLUMN	10	
540-015	4-SPOKE 18 INCH (450MM) STEERING WHEEL		
765-002	DRIVER AND PASSENGER INTERIOR SUN VISORS		

**Instruments & Controls**

732-004	GRAY DRIVER INSTRUMENT PANEL		
734-004	GRAY CENTER INSTRUMENT PANEL		
870-001	BLACK GAUGE BEZELS		
486-001	LOW AIR PRESSURE INDICATOR LIGHT AND AUDIBLE ALARM		
840-002	2 INCH PRIMARY AND SECONDARY AIR PRESSURE GAUGES		
198-003	DASH MOUNTED AIR RESTRICTION INDICATOR WITH GRADUATIONS		
721-001	97 DB BACKUP ALARM		3
149-013	ELECTRONIC CRUISE CONTROL WITH SWITCHES IN LH SWITCH PANEL		
156-007	KEY OPERATED IGNITION SWITCH AND INTEGRAL START POSITION; 4 POSITION OFF/RUN/START/ACCESSORY		
811-042	ICU3S, 132X48 DISPLAY WITH DIAGNOSTICS, 28 LED WARNING LAMPS AND DATA LINKED		
160-038	HEAVY DUTY ONBOARD DIAGNOSTICS INTERFACE CONNECTOR LOCATED BELOW LH DASH		
844-001	2 INCH ELECTRIC FUEL GAUGE		
845-011	FUEL FILTER RESTRICTION INDICATOR		
148-085	EMISSIONS LIMITED IDLE ADJUST		



Prepared for:  
 Bob Charleton  
 Pima County  
 1291 S Mission Road  
 Tucson, AZ 85713  
 Phone: 520-724-2614

Prepared by:  
 Cory Thompson  
 FREIGHTLINER OF ARIZONA  
 9899 W ROOSEVELT STREET  
 TOLLESON, AZ 85353

Data Code	Description	Weight Front	Weight Rear
856-001	ELECTRICAL ENGINE COOLANT TEMPERATURE GAUGE		
864-001	2 INCH TRANSMISSION OIL TEMPERATURE GAUGE		
830-017	ENGINE AND TRIP HOUR METERS INTEGRAL WITHIN DRIVER DISPLAY		
372-051	CUSTOMER FURNISHED AND INSTALLED PTO CONTROLS		
852-002	ELECTRIC ENGINE OIL PRESSURE GAUGE		
746-1A9	AM/FM RADIO WITH FRONT AND REAR AUXILIARY INPUTS AND J1939	10	
747-001	DASH MOUNTED RADIO		
750-002	(2) RADIO SPEAKERS IN CAB		
753-001	AM/FM ANTENNA MOUNTED ON FORWARD LH ROOF	2	
810-027	ELECTRONIC MPH SPEEDOMETER WITH SECONDARY KPH SCALE, WITHOUT ODOMETER		
817-001	STANDARD VEHICLE SPEED SENSOR		
812-001	ELECTRONIC 3000 RPM TACHOMETER		
813-1B4	DETROIT CONNECT VIRTUAL TECHNICIAN CONNECTIVITY PACKAGE (DETROIT ENGINES ONLY)		
81X-001	2 YEARS DETROIT CONNECT VIRTUAL TECHNICIAN REMOTE DIAGNOSTICS SERVICE		
162-002	IGNITION SWITCH CONTROLLED ENGINE STOP		
482-001	BW TRACTOR PROTECTION VALVE		
883-001	TRAILER HAND CONTROL BRAKE VALVE		
836-015	DIGITAL VOLTAGE DISPLAY INTEGRAL WITH DRIVER DISPLAY		
660-008	SINGLE ELECTRIC WINDSHIELD WIPER MOTOR WITH DELAY		
304-001	MARKER LIGHT SWITCH INTEGRAL WITH HEADLIGHT SWITCH		
882-004	TWO VALVE PARKING BRAKE SYSTEM WITH WARNING INDICATOR		
299-013	SELF CANCELING TURN SIGNAL SWITCH WITH DIMMER, WASHER/WIPER AND HAZARD IN HANDLE		
298-039	INTEGRAL ELECTRONIC TURN SIGNAL FLASHER WITH HAZARD LAMPS OVERRIDING STOP LAMPS		

**Design**

065-000 PAINT: ONE SOLID COLOR



Prepared for:  
 Bob Charleton  
 Pima County  
 1291 S Mission Road  
 Tucson, AZ 85713  
 Phone: 520-724-2614

Prepared by:  
 Cory Thompson  
 FREIGHTLINER OF ARIZONA  
 9899 W ROOSEVELT STREET  
 TOLLESON, AZ 85353

Data Code	Description	Weight Front	Weight Rear
<b>Color</b>			
980-5F6	CAB COLOR A: L0006EB WHITE ELITE BC		
986-020	BLACK, HIGH SOLIDS POLYURETHANE CHASSIS PAINT		
98K-998	NO FUEL TANK CABINET PAINT		
962-972	POWDER WHITE (N0006EA) FRONT WHEELS/RIMS (PKWHT21, TKWHT21, W, TW)		
966-972	POWDER WHITE (N0006EA) REAR WHEELS/RIMS (PKWHT21, TKWHT21, W, TW)		
964-020	STANDARD BLACK BUMPER PAINT		
963-003	STANDARD E COAT/UNDERCOATING		

<b>Certification / Compliance</b>			
996-001	U.S. FMVSS CERTIFICATION, EXCEPT SALES CABS AND GLIDER KITS		

<b>Secondary Factory Options</b>			
999-999	PLEASE PROVIDE GROUND CLEARANCE MEASUREMENTS AT LOWEST POINT, BOTTOM OF FUEL TANK		

**TOTAL VEHICLE SUMMARY**

<b>Weight Summary</b>			
	Weight Front	Weight Rear	Total Weight
Factory Weight <sup>+</sup>	9893 lbs	7662 lbs	17555 lbs
Dealer Installed Options	0 lbs	0 lbs	0 lbs
<b>Total Weight<sup>+</sup></b>	<b>9893 lbs</b>	<b>7662 lbs</b>	<b>17555 lbs</b>

<b>Extended Warranty</b>			
WAI-10V	EW4 DD13 VOC \$0 DEDUCTIBLE 5 YEAR/200000 MILES FULL COVERAGE		
WAK-140	ALLISON 4500 RDS SERIES TRANSMISSION EXTENDED WARRANTY, 5 YEARS/UNLIMITED MILES FEX		





Prepared for:  
Bob Charleton  
Pima County  
1291 S Mission Road  
Tucson, AZ 85713  
Phone: 520-724-2614

Prepared by:  
Cory Thompson  
FREIGHTLINER OF ARIZONA  
9899 W ROOSEVELT STREET  
TOLLESON, AZ 85353

**Dealer Installed Options**

		Weight	Weight
		Front	Rear
2	NORWOOD EQUIPMENT BODY	0	0
Total Dealer Installed Options		0 lbs	0 lbs

(+) Weights shown are estimates only.  
If weight is critical, contact Customer Application Engineering.



Prepared for:  
 Bob Charleton  
 Pima County  
 1291 S Mission Road  
 Tucson, AZ 85713  
 Phone: 520-724-2614

Prepared by:  
 Cory Thompson  
 FREIGHTLINER OF ARIZONA  
 9899 W ROOSEVELT STREET  
 TOLLESON, AZ 85353

**D I M E N S I O N S**

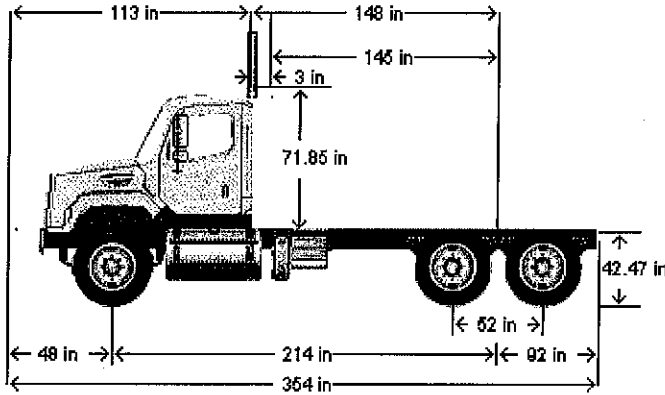

**VEHICLE SPECIFICATIONS SUMMARY - DIMENSIONS**

Model.....	114SD
Wheelbase (545) .....	5425MM (214 INCH) WHEELBASE
Rear Frame Overhang (552) .....	2325MM (92 INCH) REAR FRAME OVERHANG
Fifth Wheel (578) .....	NO FIFTH WHEEL
Mounting Location (577).....	NO FIFTH WHEEL LOCATION
Maximum Forward Position (in).....	0
Maximum Rearward Position (in) .....	0
Amount of Slide Travel (in).....	0
Slide Increment (in).....	0
Desired Slide Position (in) .....	0.0
Cab Size (829).....	114 INCH BBC FLAT ROOF ALUMINUM CONVENTIONAL CAB
Sleeper (682).....	NO SLEEPER BOX/SLEEPER/CAB
Exhaust System (016).....	RH OUTBOARD UNDER STEP MOUNTED HORIZONTAL AFTERTREATMENT SYSTEM ASSEMBLY WITH RH B-PILLAR MOUNTED VERTICAL TAILPIPE



Prepared for:  
 Bob Charleton  
 Pima County  
 1291 S Mission Road  
 Tucson, AZ 85713  
 Phone: 520-724-2614

Prepared by:  
 Cory Thompson  
 FREIGHTLINER OF ARIZONA  
 9899 W ROOSEVELT STREET  
 TOLLESON, AZ 85353

**TABLE SUMMARY - DIMENSIONS**

Dimensions	Inches
Bumper to Back of Cab (BBC)	113.4
Bumper to Centerline of Front Axle (BA)	47.9
Min. Cab to Body Clearance (CB)	3.0
Back of Cab to Centerline of Rear Axle(s) (CA)	148.4
Effective Back of Cab to Centerline of Rear Axle(s) (Effective CA)	145.4
Back of Cab Protrusions (Exhaust/Intake) (CP)	1.5
Back of Cab Protrusions (Side Extenders/Trim Tab) (CP)	0.0
Back of Cab Protrusions (CNG Tank)	0.0
Back of Cab Clearance (CL)	3.0
Back of Cab to End of Frame	240.4
Cab Height (CH)	71.9
Wheelbase (WB)	214.0
Frame Overhang (OH)	92.0
Overall Length (OAL)	353.9
Rear Axle Spacing	52.0
Unladen Frame Height at Centerline of Rear Axle	42.5

Performance calculations are estimates only. If performance calculations are critical, please contact Customer Application Engineering.



Prepared for:  
 Bob Charleton  
 Pima County  
 1291 S Mission Road  
 Tucson, AZ 85713  
 Phone: 520-724-2614

Prepared by:  
 Cory Thompson  
 FREIGHTLINER OF ARIZONA  
 9899 W ROOSEVELT STREET  
 TOLLESON, AZ 85353

**TRUCK WEIGHT**

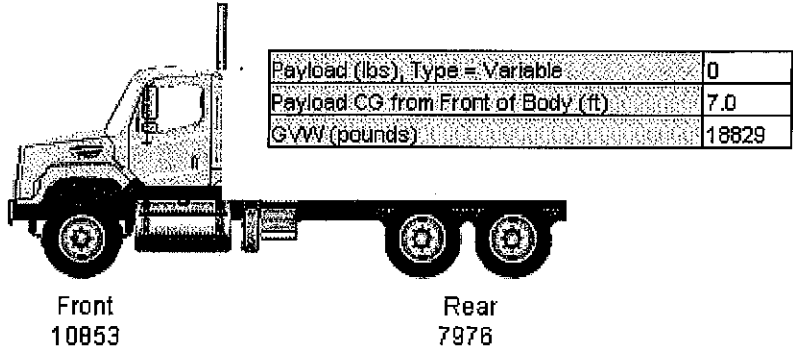

**VEHICLE SPECIFICATIONS SUMMARY - TRUCK WEIGHT**

Model.....	114SD
Cab Size (829).....	114 INCH BBC FLAT ROOF ALUMINUM CONVENTIONAL CAB
Expected Front Axle(s) Load (lbs).....	18000.0
Expected Pusher Axle(s) Load (lbs).....	0.0
Expected Rear Axle(s) Load (lbs).....	40000.0
Expected Tag Axle(s) Load (lbs).....	0.0
Expected GVW (lbs).....	58000
Expected GCW (lbs).....	80000.0
Wheelbase (545).....	5425MM (214 INCH) WHEELBASE
Pusher / Tag Axle (443).....	NO PUSHER OR TAG AXLE
Front Axle to Back of Cab (in).....	65.551
Cab to Body Clearance (in).....	3.0
Front Axle to Body (in).....	68.551
Truck Configuration (AA3).....	END DUMP BODY
Body Length (ft).....	14.0
Body Weight (lbs).....	0.0
Body Horiz CG from Body Front (ft).....	5.9
Body Front to Rear Axle(s) CL (ft).....	12.12
Driver Weight (lbs).....	500.0



Prepared for:  
 Bob Charleton  
 Pima County  
 1291 S Mission Road  
 Tucson, AZ 85713  
 Phone: 520-724-2614

Prepared by:  
 Cory Thompson  
 FREIGHTLINER OF ARIZONA  
 9899 W ROOSEVELT STREET  
 TOLLESON, AZ 85353

Driver Horizontal CG from Front Axle (in).....39.18  
 Left-Hand Fuel Tank (204)..... 100 GALLON/378 LITER ALUMINUM FUEL TANK - LH  
 Left Fuel Tank Horizontal CG (in).....59.008  
 Right-Hand Fuel Tank (206)..... NO RH FUEL TANK  
 Right Fuel Tank Horizontal CG (in).....0

**TABLE SUMMARY - TRUCK WEIGHT**

Item	Front(s)	Rear(s)	Total
Chassis Tare	9893	7662	17555
Fuel / Oil	552	222	774
Driver	408	92	500
Dealer Installed Options	0	0	0
Accessories	0	0	0
Body	0	0	0
<b>Truck Tare Weight</b>	<b>10853</b>	<b>7976</b>	<b>18829</b>
Payload	0	0	0
<b>Calculated Axle Loads</b>	<b>10853</b>	<b>7976</b>	<b>18829</b>
Expected Axle Loads / GVW	18000	40000	58000
GAWR / GVWR	18000	40000	58000
Payload CG From Front of Body		7 feet	
Payload CG From Front Axle		12.7 feet	
Payload Distribution		Variable	
All weights displayed in pounds			

Performance calculations are estimates only. If performance calculations are critical, please contact Customer Application Engineering.



Prepared for:  
 Bob Charleton  
 Pima County  
 1291 S Mission Road  
 Tucson, AZ 85713  
 Phone: 520-724-2614

Prepared by:  
 Cory Thompson  
 FREIGHTLINER OF ARIZONA  
 9899 W ROOSEVELT STREET  
 TOLLESON, AZ 85353

# Water Truck

## SPECIFICATION PROPOSAL

Data Code	Description	Weight Front	Weight Rear
<b>Price Level</b>			
PRL-14D	SD PRL-14D (EFF:10/05/15)		
<b>Data Version</b>			
DRL-042	SPECPRO21 DATA RELEASE VER 042		
<b>Vehicle Configuration</b>			
001-177	114SD CONVENTIONAL CHASSIS	7,934	6,576
004-217	2017 MODEL YEAR SPECIFIED		
002-004	SET BACK AXLE - TRUCK	480	-480
019-001	TRAILER TOWING PROVISION AT END OF FRAME FOR TRUCK	10	10
003-001	LH PRIMARY STEERING LOCATION		
<b>General Service</b>			
AA1-003	TRUCK/TRAILER CONFIGURATION		
AA6-001	DOMICILED, USA 50 STATES (INCLUDING CALIFORNIA AND CARB OPT-IN STATES)		
A85-011	CONSTRUCTION SERVICE		
A84-1GM	GOVERNMENT BUSINESS SEGMENT		
AA4-002	LIQUID BULK COMMODITY		
AA5-006	TERRAIN/DUTY: 10% (SOME) OF THE TIME, IN TRANSIT, IS SPENT ON NON-PAVED ROADS		
AB1-008	MAXIMUM 8% EXPECTED GRADE		
AB5-003	MAINTAINED GRAVEL OR CRUSHED ROCK - MOST SEVERE IN-TRANSIT (BETWEEN SITES) ROAD SURFACE		
995-1AE	FREIGHTLINER LEVEL II WARRANTY		
A66-99D	EXPECTED FRONT AXLE(S) LOAD : 18000.0 lbs		
A68-99D	EXPECTED REAR DRIVE AXLE(S) LOAD : 40000.0 lbs		
A63-99D	EXPECTED GROSS VEHICLE WEIGHT CAPACITY : 58000.0 lbs		



Prepared for:  
 Bob Charleton  
 Pima County  
 1291 S Mission Road  
 Tucson, AZ 85713  
 Phone: 520-724-2614

Prepared by:  
 Cory Thompson  
 FREIGHTLINER OF ARIZONA  
 9899 W ROOSEVELT STREET  
 TOLLESON, AZ 85353

Data Code	Description	Weight Front	Weight Rear
A70-99D	EXPECTED GROSS COMBINATION WEIGHT : 80000.0 lbs		
<b>Truck Service</b>			
AA3-003	TANK BODY		
AF4-99D	EXPECTED EMPTY BODY WEIGHT : 0.0 lbs		
<b>Tractor Service</b>			
AA2-003	TANK TRAILER		
AH6-001	SINGLE (1) TRAILER		
<b>Engine</b>			
101-2X9	DETROIT DD13 12.8L 450 HP @ 1625 RPM, 1900 GOV RPM, 1550 LB/FT @ 975 RPM		
<b>Electronic Parameters</b>			
79A-078	78 MPH ROAD SPEED LIMIT		
79B-000	CRUISE CONTROL SPEED LIMIT SAME AS ROAD SPEED LIMIT		
79G-006	5 MINUTES IDLE SHUTDOWN WITH CLUTCH AND SERVICE BRAKE OVERRIDE		
79K-007	PTO MODE ENGINE RPM LIMIT - 1100 RPM		
79M-002	PTO MODE BRAKE OVERRIDE - SERVICE BRAKE APPLIED OR PARK BRAKE NOT APPLIED		
79P-002	PTO RPM WITH CRUISE SET SWITCH - 700 RPM		
79Q-003	PTO RPM WITH CRUISE RESUME SWITCH - 800 RPM		
79S-001	PTO MODE CANCEL VEHICLE SPEED - 5 MPH		
79U-007	PTO GOVERNOR RAMP RATE - 250 RPM PER SECOND		
79W-001	ONE REMOTE PTO SPEED		
79X-005	REMOTE PTO SPEED 1 SETTING - 900 RPM		
80D-001	SOFT CRUISE CONTROL ENABLED		
80G-001	PTO MINIMUM RPM - 600		
<b>Engine Equipment</b>			
99C-017	2016 ONBOARD DIAGNOSTICS/2010 EPA/CARB/FINAL GHG17 CONFIGURATION		
99D-011	2008 CARB EMISSION CERTIFICATION - CLEAN IDLE (INCLUDES 6X4 INCH LABEL ON LOWER FORWARD CORNER OF DRIVER DOOR)		
PMT-998	NO 2013 ENGINE ESCALATOR		
13E-001	STANDARD OIL PAN		
105-001	ENGINE MOUNTED OIL CHECK AND FILL gallon		



Prepared for:  
 Bob Charleton  
 Pima County  
 1291 S Mission Road  
 Tucson, AZ 85713  
 Phone: 520-724-2614

Prepared by:  
 Cory Thompson  
 FREIGHTLINER OF ARIZONA  
 9899 W ROOSEVELT STREET  
 TOLLESON, AZ 85353

Data Code	Description	Weight Front	Weight Rear
014-1B5	SIDE OF HOOD AIR INTAKE WITH DONALDSON HIGH CAPACITY AIR CLEANER WITH SAFETY ELEMENT, FIREWALL MOUNTED		
124-1E4	LN 12V 160 AMP LONG BRUSH 2243GH PAD MOUNT ALTERNATOR WITH REMOTE BATTERY VOLT SENSE, LAMP TERMINAL AND HEX SHAFT	10	
292-071	(3) ALLIANCE MODEL 1231, GROUP 31, 12 VOLT MAINTENANCE FREE 3375 CCA THREADED STUD BATTERIES		
290-1CD	BATTERY BOX WITH ALUMINUM COVER MOUNTED SHORT SIDE TO RAIL	15	
281-001	STANDARD BATTERY JUMPERS		
282-003	SINGLE BATTERY BOX FRAME MOUNTED LH SIDE BACK OF CAB		
291-017	WIRE GROUND RETURN FOR BATTERY CABLES WITH ADDITIONAL FRAME GROUND RETURN		
289-001	NON-POLISHED BATTERY BOX COVER		
295-029	POSITIVE AND NEGATIVE POSTS FOR JUMPSTART LOCATED ON FRAME NEXT TO STARTER	2	
107-044	BW MODEL BA-921 19.0 CFM SINGLE CYLINDER AIR COMPRESSOR WITH SAFETY VALVE		
152-041	ELECTRONIC ENGINE INTEGRAL SHUTDOWN PROTECTION SYSTEM		
128-002	JACOBS COMPRESSION BRAKE		
016-1C2	RH OUTBOARD UNDER STEP MOUNTED HORIZONTAL AFTERTREATMENT SYSTEM ASSEMBLY WITH RH B-PILLAR MOUNTED VERTICAL TAILPIPE	30	25
28F-002	ENGINE AFTERTREATMENT DEVICE, AUTOMATIC OVER THE ROAD REGENERATION AND DASH MOUNTED REGENERATION REQUEST SWITCH		
239-026	10 FOOT 06 INCH (126 INCH+0/-5.9 INCH) EXHAUST SYSTEM HEIGHT		
237-1CR	RH CURVED VERTICAL TAILPIPE B-PILLAR MOUNTED ROUTED FROM STEP		
23U-001	6 GALLON DIESEL EXHAUST FLUID TANK	-35	-10
30N-003	100 PERCENT DIESEL EXHAUST FLUID FILL		
23Y-002	DIESEL EXHAUST FLUID PUMP MOUNTED AFT OF DIESEL EXHAUST FLUID TANK		
43X-002	LH MEDIUM DUTY STANDARD DIESEL EXHAUST FLUID TANK LOCATION		
43Y-001	STANDARD DIESEL EXHAUST FLUID TANK CAP		
242-011	ALUMINUM AFTERTREATMENT DEVICE/MUFFLER/TAILPIPE SHIELD(S)		





Prepared for:  
 Bob Charleton  
 Pima County  
 1291 S Mission Road  
 Tucson, AZ 85713  
 Phone: 520-724-2614

Prepared by:  
 Cory Thompson  
 FREIGHTLINER OF ARIZONA  
 9899 W ROOSEVELT STREET  
 TOLLESON, AZ 85353

Data Code	Description	Weight Front	Weight Rear
273-036	BORG WARNER (KYSOR) REAR AIR ON/OFF ENGINE FAN CLUTCH		
276-001	AUTOMATIC FAN CONTROL WITHOUT DASH SWITCH, NON ENGINE MOUNTED		
110-068	DDC SUPPLIED ENGINE MOUNTED FUEL FILTER/FUEL WATER SEPARATOR WITH WATER-IN-FUEL INDICATOR		
118-001	FULL FLOW OIL FILTER		
266-057	1500 SQUARE INCH ALUMINUM RADIATOR		
103-039	ANTIFREEZE TO -34F, OAT (NITRITE AND SILICATE FREE) EXTENDED LIFE COOLANT		
171-007	GATES BLUE STRIPE COOLANT HOSES OR EQUIVALENT		
172-001	CONSTANT TENSION HOSE CLAMPS FOR COOLANT HOSES		
270-023	HDEP FIXED RATIO COOLANT PUMP AND RADIATOR DRAIN VALVE		
155-074	DELCO 12V MOD 3.175-39MT+ OCP STARTER WITH THERMAL PROTECTION AND INTEGRATED MAGNETIC SWITCH		

**Transmission**

342-1M3	ALLISON 4500 RDS AUTOMATIC TRANSMISSION WITH PTO PROVISION	260	100
---------	--	-----	-----

**Transmission Equipment**

343-339	ALLISON VOCATIONAL PACKAGE 223 - AVAILABLE ON 3000/4000 PRODUCT FAMILIES WITH VOCATIONAL MODELS RDS, HS, MH AND TRV		
84B-012	ALLISON VOCATIONAL RATING FOR ON/OFF HIGHWAY APPLICATIONS AVAILABLE WITH ALL PRODUCT FAMILIES		
84C-023	PRIMARY MODE GEARS, LOWEST GEAR 1, START GEAR 1, HIGHEST GEAR 6, AVAILABLE FOR 3000/4000 PRODUCT FAMILIES ONLY		
84D-023	SECONDARY MODE GEARS, LOWEST GEAR 1, START GEAR 1, HIGHEST GEAR 6, AVAILABLE FOR 3000/4000 PRODUCT FAMILIES ONLY		
84E-000	PRIMARY SHIFT SCHEDULE RECOMMENDED BY DTNA AND ALLISON, THIS DEFINED BY ENGINE AND VOCATIONAL USAGE		
84F-000	SECONDARY SHIFT SCHEDULE RECOMMENDED BY DTNA AND ALLISON, THIS DEFINED BY ENGINE AND VOCATIONAL USAGE		
84G-000	PRIMARY SHIFT SPEED RECOMMENDED BY DTNA AND ALLISON, THIS DEFINED BY ENGINE AND VOCATIONAL USAGE		



Prepared for:  
 Bob Charleton  
 Pima County  
 1291 S Mission Road  
 Tucson, AZ 85713  
 Phone: 520-724-2614

Prepared by:  
 Cory Thompson  
 FREIGHTLINER OF ARIZONA  
 9899 W ROOSEVELT STREET  
 TOLLESON, AZ 85353

Data Code	Description	Weight Front	Weight Rear
84H-000	SECONDARY SHIFT SPEED RECOMMENDED BY DTNA AND ALLISON, THIS DEFINED BY ENGINE AND VOCATIONAL USAGE		
84L-000	LOAD BASED SHIFT SCHEDULE AND VEHICLE ACCELERATION CONTROL RECOMMENDED BY DTNA AND ALLISON, THIS DEFINED VOCATIONAL USAGE		
84U-000	DRIVER SWITCH INPUT - DEFAULT - NO SWITCHES		
34C-002	ELECTRONIC TRANSMISSION CUSTOMER ACCESS CONNECTOR MOUNTED BACK OF CAB		
362-157	CUSTOMER INSTALLED MUNCIE CS20/CS24 SERIES PTO		
363-001	PTO MOUNTING, LH SIDE OF MAIN TRANSMISSION		
341-018	MAGNETIC PLUGS, ENGINE DRAIN, TRANSMISSION DRAIN, AXLE(S) FILL AND DRAIN		
345-003	PUSH BUTTON ELECTRONIC SHIFT CONTROL, DASH MOUNTED		
97G-004	TRANSMISSION PROGNOSTICS - ENABLED 2013		
370-011	WATER TO OIL TRANSMISSION COOLER, FRAME MOUNTED		
346-003	TRANSMISSION OIL CHECK AND FILL WITH ELECTRONIC OIL LEVEL CHECK		
35T-001	SYNTHETIC TRANSMISSION FLUID (TES-295 COMPLIANT)		

Front Axle and Equipment			
400-1BA	DETROIT DA-F-18.0-5 18,000# FL1 71.0 KPI/3.74 DROP SINGLE FRONT AXLE	210	
402-030	MERITOR 16.5X6 Q+ CAST SPIDER CAM FRONT BRAKES, DOUBLE ANCHOR, FABRICATED SHOES	10	
403-002	NON-ASBESTOS FRONT BRAKE LINING		
419-023	CONMET CAST IRON FRONT BRAKE DRUMS		
427-001	FRONT BRAKE DUST SHIELDS	5	
409-021	SKF SCOTSEAL PLUS XL FRONT OIL SEALS		
408-001	VENTED FRONT HUB CAPS WITH WINDOW, CENTER AND SIDE PLUGS - OIL		
416-022	STANDARD SPINDLE NUTS FOR ALL AXLES		
405-002	MERITOR AUTOMATIC FRONT SLACK ADJUSTERS		
406-001	STANDARD KING PIN BUSHINGS		
536-012	TRW TAS-85 POWER STEERING	40	
539-003	POWER STEERING PUMP		



Prepared for:  
 Bob Charleton  
 Pima County  
 1291 S Mission Road  
 Tucson, AZ 85713  
 Phone: 520-724-2614

Prepared by:  
 Cory Thompson  
 FREIGHTLINER OF ARIZONA  
 9899 W ROOSEVELT STREET  
 TOLLESON, AZ 85353

Data Code	Description	Weight Front	Weight Rear
534-003	4 QUART POWER STEERING RESERVOIR	5	
40T-001	ORGANIC SAE 80/90 FRONT AXLE LUBE		
<b>Front Suspension</b>			
620-005	18,000# FLAT LEAF FRONT SUSPENSION	290	
619-004	GRAPHITE BRONZE BUSHINGS WITH SEALS - FRONT SUSPENSION		
410-998	NO FRONT SHOCK ABSORBERS	-30	
<b>Rear Axle and Equipment</b>			
420-1K4	MT-40-14XP 40,000# R-SERIES TANDEM REAR AXLE		-30
421-433	4.33 REAR AXLE RATIO		
424-003	IRON REAR AXLE CARRIER WITH OPTIONAL HEAVY DUTY AXLE HOUSING		40
386-075	MXL 18T MERITOR EXTENDED LUBE MAIN DRIVELINE WITH HALF ROUND YOKES	60	60
388-073	MXL 17T MERITOR EXTENDED LUBE INTERAXLE DRIVELINE WITH HALF ROUND YOKES		
452-005	DRIVER CONTROLLED TRACTION DIFFERENTIAL - REAR MOST TANDEM/TRIDEM REAR AXLE		20
878-021	(1) INTERAXLE LOCK VALVE AND (1) DRIVER CONTROLLED DIFFERENTIAL LOCK REAR-REAR AXLE VALVE		
87A-001	BLINKING LAMP WITH EACH INTERAXLE LOCK SWITCH, INTERAXLE UNLOCK DEFAULT WITH IGNITION OFF		
87B-004	BLINKING LAMP WITH EACH MODE SWITCH, DIFFERENTIAL UNLOCK WITH IGNITION OFF, ACTIVE <5 MPH		
423-020	MERITOR 16.5X7 Q+ CAST SPIDER CAM REAR BRAKES, DOUBLE ANCHOR, FABRICATED SHOES		
433-002	NON-ASBESTOS REAR BRAKE LINING		
434-003	STANDARD BRAKE CHAMBER LOCATION		
451-023	CONMET CAST IRON REAR BRAKE DRUMS		
440-021	SKF SCOTSEAL PLUS XL REAR OIL SEALS		
426-075	HALDEX GOLDSEAL LONGSTROKE 2-DRIVE AXLES SPRING PARKING CHAMBERS		
428-003	HALDEX AUTOMATIC REAR SLACK ADJUSTERS		
41T-001	ORGANIC SAE 80/90 REAR AXLE LUBE		
42T-001	STANDARD REAR AXLE BREATHER(S)		
<b>Rear Suspension</b>			



Prepared for:  
 Bob Charleton  
 Pima County  
 1291 S Mission Road  
 Tucson, AZ 85713  
 Phone: 520-724-2614

Prepared by:  
 Cory Thompson  
 FREIGHTLINER OF ARIZONA  
 9899 W ROOSEVELT STREET  
 TOLLESON, AZ 85353

Data Code	Description	Weight Front	Weight Rear
622-241	HENDRICKSON HN402 @40,000# REAR SUSPENSION		430
621-035	HENDRICKSON HN 400/460 - 9.56 INCH RIDE HEIGHT		
431-001	STANDARD AXLE SEATS IN AXLE CLAMP GROUP		
624-011	52 INCH AXLE SPACING		
628-010	HENDRICKSON HN, HAULMAAX AND ULTIMAAX SERIES STEEL BEAMS WITH BAR PIN		
623-006	FORE/AFT AND TRANSVERSE CONTROL RODS		100
439-002	REAR SHOCK ABSORBERS - TWO AXLES (TANDEM)		
<b>Brake System</b>			
490-100	WABCO 4S/4M ABS WITHOUT TRACTION CONTROL		
871-001	REINFORCED NYLON, FABRIC BRAID AND WIRE BRAID CHASSIS AIR LINES		
904-001	FIBER BRAID PARKING BRAKE HOSE		
412-001	STANDARD BRAKE SYSTEM VALVES		
46D-002	STANDARD AIR SYSTEM PRESSURE PROTECTION SYSTEM		
413-002	STD U.S. FRONT BRAKE VALVE		
432-003	RELAY VALVE WITH 5-8 PSI CRACK PRESSURE, NO REAR PROPORTIONING VALVE		
480-083	WABCO SS-1200 PLUS AIR DRYER WITH INTEGRAL AIR GOVERNOR AND HEATER		
483-004	WABCO OIL COALESCING FILTER FOR AIR DRYER		
479-006	AIR DRYER MOUNTED OUTBOARD ON RH RAIL		
460-001	STEEL AIR BRAKE RESERVOIRS		
477-006	BW DV-2 AUTO DRAIN VALVE WITHOUT HEATER ON ALL TANK(S)		
<b>Trailer Connections</b>			
914-001	AIR CONNECTIONS TO END OF FRAME WITH GLAD HANDS FOR TRUCK AND NO DUST COVERS		
296-010	PRIMARY CONNECTOR/RECEPTACLE WIRED FOR SEPARATE STOP/TURN, ABS CENTER PIN POWERED THROUGH IGNITION		
297-001	SAE J560 7-WAY PRIMARY TRAILER CABLE RECEPTACLE MOUNTED END OF FRAME		
335-004	UPGRADED CHASSIS MULTIPLEXING UNIT		
<b>Wheelbase &amp; Frame</b>			



Prepared for:  
 Bob Charleton  
 Pima County  
 1291 S Mission Road  
 Tucson, AZ 85713  
 Phone: 520-724-2614

Prepared by:  
 Cory Thompson  
 FREIGHTLINER OF ARIZONA  
 9899 W ROOSEVELT STREET  
 TOLLESON, AZ 85353

Data Code	Description	Weight Front	Weight Rear
545-542	5425MM (214 INCH) WHEELBASE		
546-101	11/32X3-1/2X10-15/16 INCH STEEL FRAME (8.73MMX277.8MM/0.344X10.94 INCH) 120KSI	160	50
547-001	1/4 INCH (6.35MM) C-CHANNEL INNER FRAME REINFORCEMENT	200	390
552-056	2325MM (92 INCH) REAR FRAME OVERHANG		
55W-009	FRAME OVERHANG RANGE: 91 INCH TO 100 INCH	-60	260
AC8-99D	CALC'D BACK OF CAB TO REAR SUSP C/L (CA) : 148.45 in		
AE8-99D	CALCULATED EFFECTIVE BACK OF CAB TO REAR SUSPENSION C/L (CA) : 145.45 in		
AE4-99D	CALC'D FRAME LENGTH - OVERALL : 336.12		
AM6-99D	CALC'D SPACE AVAILABLE FOR DECKPLATE : 148.45 in		
FSS-0LH	CALCULATED FRAME SPACE LH SIDE : 54.48 in		
FSS-0RH	CALCULATED FRAME SPACE RH SIDE : 102.42 in		
553-001	SQUARE END OF FRAME		
550-001	FRONT CLOSING CROSSMEMBER		
559-001	STANDARD WEIGHT ENGINE CROSSMEMBER		
562-001	STANDARD MIDSHIP #1 CROSSMEMBER(S)		
572-001	STANDARD REARMOST CROSSMEMBER		
565-002	HEAVY DUTY SUSPENSION CROSSMEMBER		30
<b>Chassis Equipment</b>			
556-1E5	14 INCH PAINTED STEEL BUMPER	20	
558-033	REMOVABLE FRONT TOW HOOKS STORED ON THE CHASSIS FRAME	25	
551-007	GRADE 8 THREADED HEX HEADED FRAME FASTENERS		
970-040	TANK BODY 3001 TO 4500 GALLONS		
<b>Fuel Tanks</b>			
204-156	100 GALLON/378 LITER ALUMINUM FUEL TANK - LH	20	
218-006	25 INCH DIAMETER FUEL TANK(S)		
215-005	PLAIN ALUMINUM/PAINTED STEEL FUEL/HYDRAULIC TANK(S) WITH PAINTED BANDS		
212-007	FUEL TANK(S) FORWARD		
664-001	PLAIN STEP FINISH		
205-001	FUEL TANK CAP(S)		
122-1F1	DAVCO 482 FUEL/WATER SEPARATOR	10	



Prepared for:  
 Bob Charleton  
 Pima County  
 1291 S Mission Road  
 Tucson, AZ 85713  
 Phone: 520-724-2614

Prepared by:  
 Cory Thompson  
 FREIGHTLINER OF ARIZONA  
 9899 W ROOSEVELT STREET  
 TOLLESON, AZ 85353

Data Code	Description	Weight Front	Weight Rear
216-020	EQUIFLO INBOARD FUEL SYSTEM		
202-016	HIGH TEMPERATURE REINFORCED NYLON FUEL LINE		
<b>Tires</b>			
093-1RJ	MICHELIN X WORKS Z 315/80R22.5 20 PLY RADIAL FRONT TIRES	100	
094-0DJ	MICHELIN XDE M/S 11R22.5 16 PLY RADIAL REAR TIRES		88
<b>Hubs</b>			
418-056	CONMET PRESET PLUS IRON FRONT HUBS		
450-056	CONMET PRESET PLUS IRON REAR HUBS		
<b>Wheels</b>			
502-433	ACCURIDE 29039 22.5X9.00 10-HUB PILOT 5.25 INSET 5-HAND STEEL DISC FRONT WHEELS	66	
505-524	MAXION WHEELS 90541 22.5X8.25 10-HUB PILOT 2-HAND STEEL DISC REAR WHEELS		
<b>Cab Exterior</b>			
829-1A2	114 INCH BBC FLAT ROOF ALUMINUM CONVENTIONAL CAB		
650-008	AIR CAB MOUNTS		
648-002	NONREMOVABLE BUGSCREEN MOUNTED BEHIND GRILLE		
667-004	FRONT FENDERS SET-BACK AXLE		
678-001	LH AND RH GRAB HANDLES		
646-041	STATIONARY BLACK GRILLE		
65X-004	BLACK HOOD MOUNTED AIR INTAKE GRILLE		
644-004	FIBERGLASS HOOD		
727-1AJ	DUAL 14 INCH ROUND POLISHED AIR HORNS	4	
726-001	SINGLE ELECTRIC HORN		
728-002	DUAL HORN SHIELDS		
657-1CV	DOOR LOCKS AND IGNITION SWITCH KEYED THE SAME WITH (4) KEYS		
575-001	REAR LICENSE PLATE MOUNT END OF FRAME		
312-068	HALOGEN COMPOSITE HEADLAMPS WITH BLACK BEZELS		
302-001	(5) AMBER MARKER LIGHTS		
294-001	INTEGRAL STOP/TAIL/BACKUP LIGHTS		
300-015	STANDARD FRONT TURN SIGNAL LAMPS		
744-1BH	DUAL WEST COAST MOLDED-IN COLOR MIRRORS		
797-001	DOOR MOUNTED MIRRORS		



Prepared for:  
 Bob Charleton  
 Pima County  
 1291 S Mission Road  
 Tucson, AZ 85713  
 Phone: 520-724-2614

Prepared by:  
 Cory Thompson  
 FREIGHTLINER OF ARIZONA  
 9899 W ROOSEVELT STREET  
 TOLLESON, AZ 85353

Data Code	Description	Weight Front	Weight Rear
796-001	102 INCH EQUIPMENT WIDTH		
743-1AP	LH AND RH 8 INCH MOLDED-IN COLOR CONVEX MIRRORS MOUNTED UNDER PRIMARY MIRRORS		
74A-001	RH DOWN VIEW MIRROR		
729-001	STANDARD SIDE/REAR REFLECTORS		
677-053	RH AFTERTREATMENT SYSTEM CAB ACCESS WITH STEEL SHIELDING		
768-043	63X14 INCH TINTED REAR WINDOW		
661-003	TINTED DOOR GLASS LH AND RH WITH TINTED NON-OPERATING WING WINDOWS		
654-003	MANUAL DOOR WINDOW REGULATORS		
663-013	TINTED WINDSHIELD		
659-019	2 GALLON WINDSHIELD WASHER RESERVOIR WITHOUT FLUID LEVEL INDICATOR, FRAME MOUNTED		
<b>Cab Interior</b>			
707-1AK	OPAL GRAY VINYL INTERIOR		
706-013	MOLDED PLASTIC DOOR PANEL		
708-013	MOLDED PLASTIC DOOR PANEL		
772-006	BLACK MATS WITH SINGLE INSULATION		
691-008	FORWARD ROOF MOUNTED CONSOLE WITH UPPER STORAGE COMPARTMENTS WITHOUT NETTING		
694-010	IN DASH STORAGE BIN		
742-007	(2) CUP HOLDERS LH AND RH DASH		
680-006	GRAY/CHARCOAL FLAT DASH		
720-003	5 LB. FIRE EXTINGUISHER	10	
700-002	HEATER, DEFROSTER AND AIR CONDITIONER		
701-001	STANDARD HVAC DUCTING		
703-005	MAIN HVAC CONTROLS WITH RECIRCULATION SWITCH		
170-015	STANDARD HEATER PLUMBING		
130-033	DENSO HEAVY DUTY AIR CONDITIONER COMPRESSOR		
702-002	BINARY CONTROL, R-134A		
739-033	STANDARD INSULATION		
285-013	SOLID-STATE CIRCUIT PROTECTION AND FUSES		
280-007	12V NEGATIVE GROUND ELECTRICAL SYSTEM		
324-014	DOMELIGHT WITH 3-WAY SWITCH ACTIVATED BY LH AND RH DOORS		



Prepared for:  
 Bob Charleton  
 Pima County  
 1291 S Mission Road  
 Tucson, AZ 85713  
 Phone: 520-724-2614

Prepared by:  
 Cory Thompson  
 FREIGHTLINER OF ARIZONA  
 9899 W ROOSEVELT STREET  
 TOLLESON, AZ 85353

Data Code	Description	Weight Front	Weight Rear
655-001	CAB DOOR LATCHES WITH MANUAL DOOR LOCKS		
284-045	(2) 12 VOLT POWER RECEPTACLES MOUNTED IN DASH		
722-002	TRIANGULAR REFLECTORS WITHOUT FLARES	10	
756-1D9	PREMIUM HIGH BACK AIR SUSPENSION DRIVER SEAT WITH 3 CHAMBER AIR LUMBAR, INTEGRATED CUSHION EXTENSION, FORWARD AND REAR CUSHION TILT, ADJUSTABLE SHOCK ABSORBER	70	
760-1DC	BASIC HIGH BACK NON SUSPENSION PASSENGER SEAT		
711-004	LH AND RH INTEGRAL DOOR PANEL ARMRESTS		
758-033	VINYL WITH CLOTH INSERT DRIVER SEAT		
761-033	VINYL WITH CLOTH INSERT PASSENGER SEAT		
763-101	BLACK SEAT BELTS		
532-002	ADJUSTABLE TILT AND TELESCOPING STEERING COLUMN	10	
540-015	4-SPOKE 18 INCH (450MM) STEERING WHEEL		
765-002	DRIVER AND PASSENGER INTERIOR SUN VISORS		

**Instruments & Controls**

732-004	GRAY DRIVER INSTRUMENT PANEL		
734-004	GRAY CENTER INSTRUMENT PANEL		
870-001	BLACK GAUGE BEZELS		
486-001	LOW AIR PRESSURE INDICATOR LIGHT AND AUDIBLE ALARM		
840-002	2 INCH PRIMARY AND SECONDARY AIR PRESSURE GAUGES		
198-003	DASH MOUNTED AIR RESTRICTION INDICATOR WITH GRADUATIONS		
721-001	97 DB BACKUP ALARM		3
149-013	ELECTRONIC CRUISE CONTROL WITH SWITCHES IN LH SWITCH PANEL		
156-007	KEY OPERATED IGNITION SWITCH AND INTEGRAL START POSITION; 4 POSITION OFF/RUN/START/ACCESSORY		
811-042	ICU3S, 132X48 DISPLAY WITH DIAGNOSTICS, 28 LED WARNING LAMPS AND DATA LINKED		
160-038	HEAVY DUTY ONBOARD DIAGNOSTICS INTERFACE CONNECTOR LOCATED BELOW LH DASH		
844-001	2 INCH ELECTRIC FUEL GAUGE		
845-011	FUEL FILTER RESTRICTION INDICATOR		





Prepared for:  
 Bob Charleton  
 Pima County  
 1291 S Mission Road  
 Tucson, AZ 85713  
 Phone: 520-724-2614

Prepared by:  
 Cory Thompson  
 FREIGHTLINER OF ARIZONA  
 9899 W ROOSEVELT STREET  
 TOLLESON, AZ 85353

Data Code	Description	Weight Front	Weight Rear
148-085	EMISSIONS LIMITED IDLE ADJUST		
856-001	ELECTRICAL ENGINE COOLANT TEMPERATURE GAUGE		
864-001	2 INCH TRANSMISSION OIL TEMPERATURE GAUGE		
830-017	ENGINE AND TRIP HOUR METERS INTEGRAL WITHIN DRIVER DISPLAY		
372-051	CUSTOMER FURNISHED AND INSTALLED PTO CONTROLS		
852-002	ELECTRIC ENGINE OIL PRESSURE GAUGE		
746-1A9	AM/FM RADIO WITH FRONT AND REAR AUXILIARY INPUTS AND J1939	10	
747-001	DASH MOUNTED RADIO		
750-002	(2) RADIO SPEAKERS IN CAB		
753-001	AM/FM ANTENNA MOUNTED ON FORWARD LH ROOF	2	
810-027	ELECTRONIC MPH SPEEDOMETER WITH SECONDARY KPH SCALE, WITHOUT ODOMETER		
817-001	STANDARD VEHICLE SPEED SENSOR		
812-001	ELECTRONIC 3000 RPM TACHOMETER		
813-1B4	DETROIT CONNECT VIRTUAL TECHNICIAN CONNECTIVITY PACKAGE (DETROIT ENGINES ONLY)		
81X-001	2 YEARS DETROIT CONNECT VIRTUAL TECHNICIAN REMOTE DIAGNOSTICS SERVICE		
162-002	IGNITION SWITCH CONTROLLED ENGINE STOP		
482-001	BW TRACTOR PROTECTION VALVE		
883-001	TRAILER HAND CONTROL BRAKE VALVE		
836-015	DIGITAL VOLTAGE DISPLAY INTEGRAL WITH DRIVER DISPLAY		
660-008	SINGLE ELECTRIC WINDSHIELD WIPER MOTOR WITH DELAY		
304-001	MARKER LIGHT SWITCH INTEGRAL WITH HEADLIGHT SWITCH		
882-004	TWO VALVE PARKING BRAKE SYSTEM WITH WARNING INDICATOR		
299-013	SELF CANCELING TURN SIGNAL SWITCH WITH DIMMER, WASHER/WIPER AND HAZARD IN HANDLE		
298-039	INTEGRAL ELECTRONIC TURN SIGNAL FLASHER WITH HAZARD LAMPS OVERRIDING STOP LAMPS		

**Design**

065-000 PAINT: ONE SOLID COLOR



Prepared for:  
 Bob Charleton  
 Pima County  
 1291 S Mission Road  
 Tucson, AZ 85713  
 Phone: 520-724-2614

Prepared by:  
 Cory Thompson  
 FREIGHTLINER OF ARIZONA  
 9899 W ROOSEVELT STREET  
 TOLLESON, AZ 85353

Data Code	Description	Weight Front	Weight Rear
<b>Color</b>			
980-5F6	CAB COLOR A: L0006EB WHITE ELITE BC		
986-020	BLACK, HIGH SOLIDS POLYURETHANE CHASSIS PAINT		
98K-998	NO FUEL TANK CABINET PAINT		
962-972	POWDER WHITE (N0006EA) FRONT WHEELS/RIMS (PKWHT21, TKWHT21, W, TW)		
966-972	POWDER WHITE (N0006EA) REAR WHEELS/RIMS (PKWHT21, TKWHT21, W, TW)		
964-020	STANDARD BLACK BUMPER PAINT		
963-003	STANDARD E COAT/UNDERCOATING		

<b>Certification / Compliance</b>			
996-001	U.S. FMVSS CERTIFICATION, EXCEPT SALES CABS AND GLIDER KITS		

**T O T A L V E H I C L E S U M M A R Y**

<b>Weight Summary</b>			
	Weight Front	Weight Rear	Total Weight
Factory Weight <sup>+</sup>	9953 lbs	7662 lbs	17615 lbs
Dealer Installed Options	0 lbs	0 lbs	0 lbs
<b>Total Weight<sup>+</sup></b>	<b>9953 lbs</b>	<b>7662 lbs</b>	<b>17615 lbs</b>

<b>Extended Warranty</b>	
WAI-10V	EW4 DD13 VOC \$0 DEDUCTIBLE 5 YEAR/200000 MILES FULL COVERAGE
WAK-140	ALLISON 4500 RDS SERIES TRANSMISSION EXTENDED WARRANTY, 5 YEARS/UNLIMITED MILES FEX

<b>Dealer Installed Options</b>			
		Weight Front	Weight Rear



Prepared for:  
Bob Charleton  
Pima County  
1291 S Mission Road  
Tucson, AZ 85713  
Phone: 520-724-2614

Prepared by:  
Cory Thompson  
FREIGHTLINER OF ARIZONA  
9899 W ROOSEVELT STREET  
TOLLESON, AZ 85353

2	MADDOCK MACHINERY BODY	0	0
	Total Dealer Installed Options	0 lbs	0 lbs

(+) Weights shown are estimates only.  
If weight is critical, contact Customer Application Engineering.



Prepared for:  
 Bob Charleton  
 Pima County  
 1291 S Mission Road  
 Tucson, AZ 85713  
 Phone: 520-724-2614

Prepared by:  
 Cory Thompson  
 FREIGHTLINER OF ARIZONA  
 9899 W ROOSEVELT STREET  
 TOLLESON, AZ 85353

**D I M E N S I O N S**

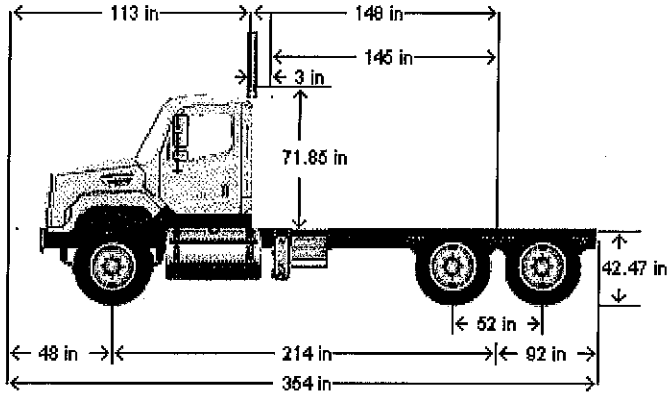

**VEHICLE SPECIFICATIONS SUMMARY - DIMENSIONS**

Model.....114SD  
 Wheelbase (545) ..... 5425MM (214 INCH) WHEELBASE  
 Rear Frame Overhang (552)..... 2325MM (92 INCH) REAR FRAME OVERHANG  
 Fifth Wheel (578) ..... NO FIFTH WHEEL  
   Mounting Location (577)..... NO FIFTH WHEEL LOCATION  
   Maximum Forward Position (in).....0  
   Maximum Rearward Position (in) .....0  
   Amount of Slide Travel (in).....0  
   Slide Increment (in).....0  
   Desired Slide Position (in).....0.0  
 Cab Size (829)..... 114 INCH BBC FLAT ROOF ALUMINUM CONVENTIONAL CAB  
 Sleeper (682)..... NO SLEEPER BOX/SLEEPER CAB  
 Exhaust System (016)..... RH OUTBOARD UNDER STEP MOUNTED HORIZONTAL AFTERTREATMENT SYSTEM ASSEMBLY WITH RH B-PILLAR MOUNTED VERTICAL TAILPIPE



Prepared for:  
 Bob Charleton  
 Pima County  
 1291 S Mission Road  
 Tucson, AZ 85713  
 Phone: 520-724-2614

Prepared by:  
 Cory Thompson  
 FREIGHTLINER OF ARIZONA  
 9899 W ROOSEVELT STREET  
 TOLLESON, AZ 85353

**TABLE SUMMARY - DIMENSIONS**

Dimensions	Inches
Bumper to Back of Cab (BBC)	113.4
Bumper to Centerline of Front Axle (BA)	47.9
Min. Cab to Body Clearance (CB)	3.0
Back of Cab to Centerline of Rear Axle(s) (CA)	148.4
Effective Back of Cab to Centerline of Rear Axle(s) (Effective CA)	145.4
Back of Cab Protrusions (Exhaust/Intake) (CP)	1.5
Back of Cab Protrusions (Side Extenders/Trim Tab) (CP)	0.0
Back of Cab Protrusions (CNG Tank)	0.0
Back of Cab Clearance (CL)	3.0
Back of Cab to End of Frame	240.4
Cab Height (CH)	71.9
Wheelbase (WB)	214.0
Frame Overhang (OH)	92.0
Overall Length (OAL)	353.9
Rear Axle Spacing	52.0
Unladen Frame Height at Centerline of Rear Axle	42.5

Performance calculations are estimates only. If performance calculations are critical, please contact Customer Application Engineering.





Prepared for:  
 Bob Charleton  
 Pima County  
 1291 S Mission Road  
 Tucson, AZ 85713  
 Phone: 520-724-2614

Prepared by:  
 Cory Thompson  
 FREIGHTLINER OF ARIZONA  
 9899 W ROOSEVELT STREET  
 TOLLESON, AZ 85353

Driver Horizontal CG from Front Axle (in) ..... 39.18  
 Left-Hand Fuel Tank (204) ..... 100 GALLON/378 LITER ALUMINUM FUEL TANK - LH  
 Left Fuel Tank Horizontal CG (in) ..... 59.008  
 Right-Hand Fuel Tank (206) ..... NO RH FUEL TANK  
 Right Fuel Tank Horizontal CG (in) ..... 0

**TABLE SUMMARY - TRUCK WEIGHT**

Item	Front(s)	Rear(s)	Total
Chassis Tare	9953	7662	17615
Fuel / Oil	552	222	774
Driver	408	92	500
Dealer Installed Options	0	0	0
Accessories	0	0	0
Body	0	0	0
<b>Truck Tare Weight</b>	<b>10913</b>	<b>7976</b>	<b>18889</b>
Payload	0	0	0
<b>Calculated Axle Loads</b>	<b>10913</b>	<b>7976</b>	<b>18889</b>
Expected Axle Loads / GW	18000	40000	58000
GAWR / GVWR	18000	40000	58000
Payload CG From Front of Body		7.5 feet	
Payload CG From Front Axle		13.2 feet	
Payload Distribution		Variable	
All weights displayed in pounds.			

Performance calculations are estimates only. If performance calculations are critical, please contact Customer Application Engineering.



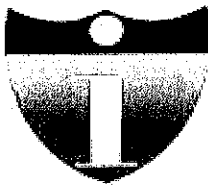

# INTERSTATE

Truck Bodies, Inc.

Manufacturers/Designers  
Of Construction Equipment

3215 W. LINCOLN ST. \* PHOENIX, AZ 85009  
PHONE (602) 269-2121 FAX (602) 269-5021

PIMA COUNTY  
Contract #: #229988

DATE: SEPTEMBER 22, 2016

NAME: PIMA COUNTY

ATTN:

ADDRESS: 130 W. CONGRESS, 3<sup>RD</sup> FLOOR

TUCSON, AZ 85701

PHONE:

FAX: 520-838-7553

THE UNDERSIGNED ("BUYER"), HEREBY AGREES TO PURCHASE FROM INTERSTATE TRUCK BODIES, INC., ("SELLER") THE FOLLOWING EQUIPMENT:

E-MAIL:

## NEW ITB MODEL SE1642 SEMI ELLIPTICAL DUMP BODY

- 16' LONG, 96" WIDE, 84" INSIDE WIDTH;
- 8" LONG SILLS WITH INTERNAL CROSS MEMBERS MOUNTED ON RUBBER SKIRT BOARD;
- CROSS MEMBERLESS DESIGN BODY;
- FRONT WALL, SIDES, FLOOR AND TAIL GATE MADE FROM 1/4" AR450 STEEL;
- 54" FRONT WALL, 42" SIDES AND 42" TAIL GATE;
- HI-LIFT TAILGATE WITH REINFORCED CORNERS;
- 4" SQUARE TUBE TOP RAIL; 2 PIECE SIDES AND FLOOR;
- 14" REAR BODY POSTS WITH RECESSED LIGHTS;
- 1/2 CAB GUARD;
- DOGHOUSE STYLE FRONT MOUNT HOIST;
- AIR OPERATED GATE LATCHES (CAB CONTROLLED);
- STANDARD SWING TAIL GATE;
- TANDEM AXLE STEEL FENDERS;
- 12" FULL WIDTH SPREADER APRON 1/4" AR400 WITH SAFETY CHAINS;
- HEAVY DUTY REAR HINGE WITH GREASABLE PINS;
- HOT SHIFT PTO, DIRECT MOUNT PUMP AND CAB CONTROLS;
- FRAME MOUNTED HYDRAULIC RESIVORE ;
- BACK UP ALARM, LIGHTS, MUD FLAPS, REFLECTIVE TAPE AND REFLECTORS MEET DOT SPECIFICATIONS;
- HYDRAULIC FLUID, HOSES AND FITINGS;
- HEAVY DUTY BED GUIDES, BODY UP INDECATOR LIGHT AND BODY UP SAFETY PROP;
- HEAVY DUTY HITCH PLATE WITH AIR, ELECTRIC AND PH200 OR EQUAL AIR PINTLE HITCH;
- ALL HINGE PINS GREASABLE;
- SAND BLAST BODY, EPOXY SEAL AND PAINT POLYURETHANE WHITE;
- PULL TARP BRAND ALUMINUM ELECTRIC TARP SYSTEM WITH HEAVY DUTY MESH TARP;

YEAR: \_\_\_\_\_  
MAKE: \_\_\_\_\_  
ID#: \_\_\_\_\_

SELLING PRICE:	_____
TAX (9.30%)	IF APPLIC. _____
F.E.T.	N/A _____
DELIVERY CHARGE	FOB, PHX. _____
DEPOSIT	N/A _____
BALANCE DUE	_____
(ON COMPLETION PRIOR TO SHIPMENT)	

INTERSTATE TRUCK BODY CO. WILL NOT RELEASE ANY UNIT WITHOUT PAYMENT IN FULL. NO EXCEPTIONS.

ALL CABS / CHASSIS SOLD "AS IS", WITH NO EXPRESSED OR IMPLIED WARRANTIES UNLESS WARRANTED BY CHASSIS MANUFACTURER.

CONTRACT PRICE IS VALID FOR 10 DAYS FROM THE DATE OF INTERSTATE TRUCK BODIES, INC. QUOTE, SUBJECT TO PRIOR SALE.

**NOTE:** PURCHASER(S) ACCEPTANCE OF CONTRACT ACKNOWLEDGES THEY HAVE READ, UNDERSTAND AND AGREE TO TERMS AND CONDITIONS AND WARRANTY PROVIDED WITH AGREEMENT.

SELLER: MIKE MILLER  
SALESPERSON

ACCEPTED INTERSTATE TRUCK BODIES, INC.

ACCEPTED PURCHASER:

BY: \_\_\_\_\_  
DATE: \_\_\_\_\_

BY: \_\_\_\_\_  
DATE: \_\_\_\_\_



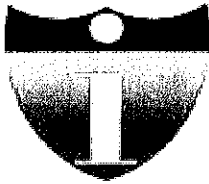

# INTERSTATE

Truck Bodies, Inc.

Manufacturers/Designers  
Of Construction Equipment

3215 W. LINCOLN ST. \* PHOENIX, AZ 85009  
PHONE (602) 269-2121 FAX (602) 269-5021

PIMA  
COUNTY  
Contract #: #229988

DATE: **SEPTEMBER 22, 2016**

NAME: PIMA COUNTY  
ATTN: \_\_\_\_\_  
ADDRESS: 130 W. CONGRESS, 3<sup>RD</sup> FLOOR  
TUCSON, AZ 85701  
PHONE: \_\_\_\_\_ FAX: 520-838-7553

THE UNDERSIGNED ("BUYER"), HEREBY AGREES TO PURCHASE FROM INTERSTATE TRUCK BODIES, INC., ("SELLER") THE FOLLOWING EQUIPMENT:

E-MAIL:

## 4000 GALLON STAINLESS STEEL WATER TANK SYSTEM:

- 4000 GALLON ELLIPTICAL DESIGN TANK 3/16" (7GA) 304 STAINLESS STEEL
- TANK HEADS AND BAFFLES WELDED BOTH SIDES 360 DEGREES
- 20" CRAWL SPACE THRU BAFFLES
- SPRING MOUNTS AT FRONT OF TANK AND SOLID MOUNT AT REAR
- 3 MOUNTS PER SIDE WITH VULCANISED WEAR RUBBER
- 25" DIAMETER MANWAY WITH HINGED MANWAY LID
- NON SKID LADDER AND WALKWAY TO MANWAY
- SIGN RACK MOUNTED SIDE OF FRAME
- DRAIN AND SUMP WITH ANTI SWIRL BAFFLE
- REAR ANTI SIPHON FILL PIPE WITH ONE WAY VALVE
- SIGHT TUBE WITH SHUT OFF VALVES
- LEGAL LOAD VALVE
- HOT SHIFT PTO WITH ADJUSTABLE OVERSPEED PROTECTION
- DIRECT MOUNT MAIN HYDRAULIC PUMP, HYDRAULIC MOTER TO WATER PUMP
- HYDRAULIC RESIVORE WITH SHUT OFF VALVES, LEVEL INDICATOR
- BERKELEY B4ZRKS SELF PRIMING PUMP WITH HYDRAULIC ADAPTER
- (5) 3" AIR SPRAYS, (2) FRONT BUMPER, (2) REAR CORNERS OF TANK, (1) FRONT SIDE OF TANK
- (5) INDIVIDUAL AIR CONTROLS, CAB MOUNTED FOR EASY ACCESS
- 2" JET VALVE ON PRESSURE MANIFOLD
- GRAVITY BAR WITH REMOVABLE ENDS FOR EASE OF CLEANING
- (2) REAR TANK WORK LIGHTS WITH CAB MOUNTED SWITCH, (2) WARNING LIGHTS ON REAR HEAD
- TANK MOUNTED TAILLIGHTS, ALL LIGHTS MEET DOT SPECIFICATIONS
- REAR HITCH PLATE WITH HOLLAND PH-200 PINTLE, AIR GLAD HANDS, ELECTRICAL PLUG D-RINGS
- REMOVE ALL CONTANIMENTS FROM STAINLESS STEEL, APPLY STAINLESS ETCHING PRIMER COAT WITH 2 COATS POLYURETHANE

YEAR: \_\_\_\_\_  
MAKE: \_\_\_\_\_  
ID#: \_\_\_\_\_

SELLING PRICE:	_____
TAX (9.30%)	<u>IF APPLIC.</u>
F.E.T.	<u>N/A</u>
DELIVERY CHARGE	<u>FOB, PHX.</u>
DEPOSIT	<u>N/A</u>
<b>BALANCE DUE</b>	_____
<b>(ON COMPLETION <u>PRIOR</u> TO SHIPMENT)</b>	

INTERSTATE TRUCK BODY CO. WILL NOT RELEASE ANY UNIT WITHOUT PAYMENT IN FULL. **NO EXCEPTIONS.**

CONTRACT PRICE IS VALID FOR **10 DAYS** FROM THE DATE OF INTERSTATE TRUCK BODIES, INC. QUOTE, SUBJECT TO PRIOR SALE.

**NOTE:** PURCHASER(S) ACCEPTANCE OF CONTRACT ACKNOWLEDGES THEY HAVE READ, UNDERSTAND AND AGREE TO TERMS AND CONDITIONS AND WARRANTY PROVIDED WITH AGREEMENT.

SELLER: MIKE MILLER  
SALESPERSON

**ACCEPTED INTERSTATE TRUCK BODIES, INC.**

**ACCEPTED PURCHASER:**

BY: \_\_\_\_\_  
DATE: \_\_\_\_\_

BY: \_\_\_\_\_  
DATE: \_\_\_\_\_